



KIITPOLYTECHNIC

LECTURE NOTES

ON

REFRIGERATION AND AIR CONDITIONING

Compiled by

Mr. Durga Sankar Panda

(Lecturer in Department of Mechanical Engineering, KIIT Polytechnic BBSR)

Email Id: - durgasankarfme@kp.kiit.ac.in

CONTENTS

S.No	Chapter Name	Page No
1	AIR REFRIGERATION CYCLE	1-11
2	SIMPLE VAPOUR COMPRESSION REFRIGERATION SYSTEM	12-16
3	VAPOUR ABSORPTION REFRIGERATION SYSTEM	17-20
4	REFRIGERATION EQUIPMENTS	21-30
5	REFRIGERANT FLOW CONTROLS, REFRIGERANTS & APPLICATION OF REFRIGERANTS	31-33
6	PSYCHOMETRICS & COMFORT AIR CONDITIONING SYSTEMS	34-49
7	AIR CONDITIONING SYSTEMS	50-53

CH-1

AIR REFRIGERATION CYCLE

1. INTRODUCTION

Refrigeration may be defined as the process of achieving and maintaining a temperature below that of the surroundings, the aim being to cool some product or space to the required temperature.

DEFINITION:-

The term 'refrigeration' may be defined as the process of removing heat from a substance under controlled conditions. It also includes the process of reducing and maintaining the temperature of a body below the general temperature of its surroundings.

AIR CONDITIONING SYSTEMS:-

The air conditioning is that branch of engineering science which deals with the study of conditioning of air, supplying and maintaining desirable internal atmospheric conditions for human comfort, irrespective of external conditions. This subject, in its broad sense, also deals with the conditioning of air for industrial purposes, food processing, storage of food and other materials.

HEAT ENGINE:-

In a heat engine, the heat supplied to the engine is converted into useful work. If Q_2 is the heat supplied to the engine and Q_1 is the heat rejected from the engine, then the net work done by the engine is given by

$$W_E = Q_2 - Q_1$$

The performance of a heat engine is expressed by its efficiency. We know that the efficiency or coefficient of performance of an engine,

$$\eta_E \text{ or (C.O.P.)}_E = \frac{\text{Work done}}{\text{Heat supplied}} = \frac{W_E}{Q_2} = \frac{Q_2 - Q_1}{Q_2}$$

REFRIGERATOR:-

A refrigerator is a reversed heat engine which either cool or maintain the temperature of a body (T_1) lower than the atmospheric temperature (T_a). This is done by extracting the heat (Q_1) from a cold body and delivering it to a hot body (Q_2).

The performance of a refrigerator is expressed by the ratio of amount of heat taken from the cold body (Q_1) to the amount of work required to be done on the system (W_R). This ratio is called coefficient of performance. Mathematically, coefficient of performance of a refrigerator,

$$\text{(C.O.P.)}_R = \frac{Q_1}{W_R} = \frac{Q_1}{Q_2 - Q_1}$$

HEAT PUMP:-

The heat pump which extracts heat (Q_1) from a cold body and delivers it to a hot body. Thus there is no difference between the cycle of operations of a heat pump and a refrigerator. The main difference between the two is in their operating temperatures.

The performance of a heat pump is expressed by the ratio of the amount of heat delivered to the hot body (Q_2) to the amount of work required to be done on the system (W_P). This ratio is called coefficient of performance or energy performance ratio (E.P.R.) of a heat pump. Mathematically, coefficient of performance or energy performance ratio of heat pump,

$$\begin{aligned} \text{(C.O.P.)}_P \text{ or E.P.R.} &= \frac{Q_2}{W_P} = \frac{Q_2}{Q_2 - Q_1} \\ &= \frac{Q_1}{Q_2 - Q_1} + 1 = \text{(C.O.P.)}_R + 1 \end{aligned}$$

FIG

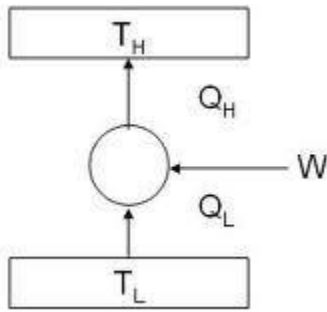

Heat pump & Refrigerator

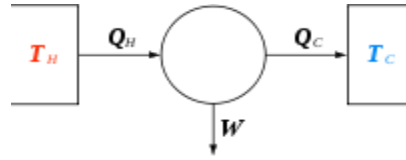

Heat Engine

UNITS OF REFRIGERATION:-

A tonne of refrigeration is defined as the amount of refrigeration effect produced by the uniform melting of one tonne (1000kg) of ice from and at 0°C in 24 hours.

Since the latent heat of ice is 335 kJ/kg, therefore one tonne of refrigeration, 1 TR = 1000X335 kJ in 24 hours

$$= \frac{1000 \times 335}{24 \times 60} = 232.6 \text{ kJ/min}$$

In actual practice, one tonne of refrigeration is taken as equivalent to 210 kJ/min or 3.5 kW (3.5kJ/s).

COEFFICIENT OF PERFORMANCE OF A REFRIGERATOR:-

The coefficient of performance (C.O.P.) is the ratio of heat extracted in the refrigerator to the work done on the refrigerant.

Mathematically,

$$\text{Theoretical C.O.P.} = \frac{Q}{W}$$

Where Q= Amount of heat extracted in the refrigerator (or the amount of refrigeration produced, or the capacity of a refrigerator), and W= Amount of work done.

AIR REFRIGERATOR WORKING ON REVERSED CARNOT CYCLE:-

FIG

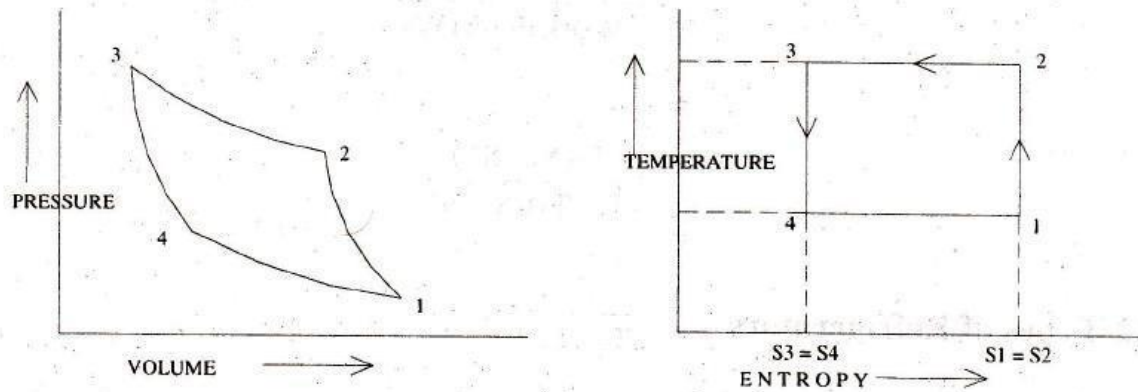

Fig 2.21 Reversed carnot cycle

A reversed Carnot cycle, using air as working medium (refrigerant) is shown on p-v and T-s diagrams.

1. Isentropic compression process. The air is compressed isentropically as shown by the curve 1-2 on p-v and T-s diagrams. During this process, the pressure of air increases from p_1 to p_2 , specific volume decreases v_1 to v_2 and temperature increases from T_1 to T_2 . We know that during isentropic compression, no heat is absorbed or rejected by the air.
2. Isothermal compression process. The air is now compressed isothermally (at constant temperature, $T_2=T_3$) as shown by the curve 2-3 on p-v and T-s diagrams. During this process, the pressure of air increases from p_2 to p_3 and specific volume decreases from v_2 to v_3 . we know that the heat rejected by the air during isothermal compression per kg of air,

$$q_{2-3} = \text{Area } 2-3-3'-2'$$

$$= T_3 (s_2-s_3) = T_2 (s_2-s_3)$$

3. Isentropic expansion process. The air is now expanded isentropically as shown by the curve 3-4 on p-v and T-s diagrams. The pressure of air decreases from p_3 to p_4 , specific volume increases from v_3 to v_4 and the temperature decreases from T_3 to T_4 , we known that during isentropic expansion no heat is absorbed or rejected by the air.
4. Isothermal expansion process. The air is now expanded isothermally (at constant temperature, $T_4 = T_1$) as shown by the curve 4-1 on p-v and T-s diagrams. The pressure of air decreases from p_4 to p_1 , and specific volume increases from v_4 to v_3 . We know that the heat absorbed by the air (or heat extracted from the cold body) during isothermal expansion per kg or air,

$$q_{4-1} = \text{Area } 4-1-2'-3'$$

$$= T_4 (s_1-s_4) = T_4 (s_2-s_3) = T_1 (s_2-s_3)$$

We know that work done during the cycle per kg of air

$$= \text{Heat rejected} - \text{Heat absorbed} = q_{2-3} - q_{4-1}$$

$$= T_2 (s_2-s_3) - T_1 (s_2-s_3) = (T_2-T_1)(s_2-s_3)$$

∴ Coefficient of performance of the refrigeration system working on reversed Carnot cycle,

$$\begin{aligned}
 (\text{C.O.P.})_R &= \frac{\text{Heat absorbed}}{\text{Workdone}} = \frac{q_{4-1}}{q_{2-3} - q_{4-1}} \\
 &= \frac{T_1(s_2 - s_3)}{(T_2 - T_1)(s_2 - s_3)} =
 \end{aligned}$$

AIR REFRIGERATOR WORKING ON A BELL-COLEMAN CYCLE (REVERSED BRAYTON OR JOULE CYCLE):

FIG

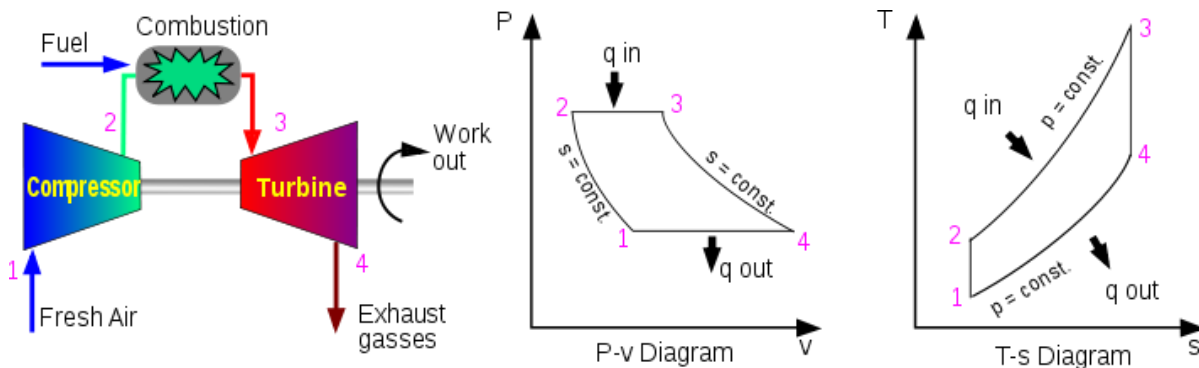

A Bell-Coleman air refrigeration machine was developed by Bell-Coleman and light foot by reversing the Joule's air cycle.

The Bell-Coleman cycle (reversed Brayton or Joule cycle) is a modification of reversed Carnot cycle. The cycle is shown on p-v and T-s diagrams.

1. Isentropic compression process. The cold air from the refrigerator is drawn into the compressor cylinder where it is compressed isentropically in the compressor as shown by the curve 1-2 on p-v and T-s diagrams.
2. Constant pressure cooling process. The warm air from the compressor is now passed into the cooler where it is cooled at constant pressure p_3 (equal to p_2), reducing the temperature from T_2 to T_3 (the temperature of cooling water) as shown by the curve 2-3 on p-v and T-s diagrams. The specific volume also reduces from v_2 to v_3 . We know that heat rejected by the air during constant pressure per kg of air,

$$Q_{2-3} = c_p(T_2 - T_3)$$

- Isentropic expansion process. The air from the cooler is now drawn into the expander cylinder where it is expanded isentropically from pressure p_3 to the refrigerator pressure p_4 which is equal to the atmospheric pressure. The temperature of air during expansion falls from T_3 to T_4 .
- Constant pressure expansion process. The cold air from the expander is now passed to the refrigerator where it is expanded at constant pressure p_4 (equal to p_1). The temperature of air increases from T_4 to T_1 . This process is shown by the curve 4-1 on the p-v and T-s diagrams. Heat absorbed by the air (heat extracted from the refrigerator) during constant pressure expansion per kg of air is:

$$q_{4-1} = c_p (T_1 - T_4)$$

We know that work done during the cycle per kg of air

$$= \text{Heat rejected} - \text{Heat absorbed}$$

$$= c_p(T_2 - T_3) - c_p (T_1 - T_4)$$

∴ Coefficient of performance,

$$\text{C.O.P.} = \frac{\text{Heat absorbed}}{\text{Workdone}} = \frac{c_p(T_1 - T_4)}{c_p(T_2 - T_3) - c_p(T_1 - T_4)}$$

$$\begin{aligned} &= \frac{(T_1 - T_4)}{(T_2 - T_3) - (T_1 - T_4)} \\ &= \frac{T_4 \left(\frac{T_1}{T_4} - 1 \right)}{T_3 \left(\frac{T_2}{T_3} - 1 \right) - T_4 \left(\frac{T_1}{T_4} - 1 \right)} \end{aligned} \quad \dots(i)$$

We know that for isentropic compression process 1-2,

$$\frac{T_2}{T_1} = \left(\frac{p_2}{p_1} \right)^\gamma \quad \dots(ii)$$

Similarly, for isentropic expansion process 3-4.

$$\frac{T_3}{T_4} = \left(\frac{p_3}{p_4} \right)^\gamma \quad \dots(iii)$$

Since $p_2 = p_3$ and $p_1 = p_4$, therefore from equation (ii) and (iii),

$$\frac{T_2}{T_1} = \frac{T_3}{T_4} \quad \text{or} \quad \frac{T_2}{T_3} = \frac{T_1}{T_4} \quad \dots(iv)$$

Now substituting these values in equation (i), we get

$$\begin{aligned} \text{C.O.P.} &= \frac{T_4}{T_3 - T_4} = \frac{1}{\frac{T_3}{T_4} - 1} \\ &= \frac{1}{\left(\frac{p_3}{p_4} \right)^\gamma - 1} = \frac{1}{\left(\frac{p_2}{p_1} \right)^\gamma - 1} = \frac{1}{(r_p)^\gamma - 1} \end{aligned} \quad \dots(v)$$

Where $r_p = \text{Compression or Expansion ratio} = \frac{p_2}{p_1} = \frac{p_3}{p_4}$

Example-

A machine working on a Carnot cycle operates between 305°K and 260°K determine the C.O.P. when it is operated as

- Refrigerator;
- Heat pump;
- Heat engine.

Solution:-

Given: $T_2 = 305^\circ\text{K}$ $T_1 = 260^\circ\text{K}$

- C.O.P. of a refrigerating machine

We know that C.O.P. of a refrigerating machine,

$$(\text{C.O.P.})_R = \frac{T_1}{T_2 - T_1} = \frac{260}{305 - 260} = 5.78 \quad (\text{Ans})$$

2. C.O.P. of a heat pump

We know that C.O.P. of a heat pump,

$$(\text{C.O.P.})_P = \frac{T_2}{T_2 - T_1} = \frac{305}{305 - 260} = 6.78 \quad (\text{Ans})$$

3. C.O.P. of a heat engine

We know that C.O.P. of a heat engine,

$$(\text{C.O.P.})_E = \frac{T_2 - T_1}{T_2} = \frac{305 - 260}{305} = 0.147 \text{ or } 14.7\% \quad (\text{Ans})$$

Example –

A Carnot refrigeration cycle absorbs heat at 270°K and rejects it at 300°K

1. Calculate the coefficient of performance of this refrigeration cycle.
2. If the cycle is absorbing 1130 KJ/min at 270°K, how many KJ of work is required per second?
3. If the Carnot heat pump operates between the same temperatures as the above refrigeration cycle, what is the Coefficient of performance?
4. How many KJ/min will the heat pump deliver at 300°K if it absorbs 1130 KJ/min at 270°K.

Solution -

Given: $T_1 = 270^\circ \text{K}$; $T_2 = 300^\circ \text{K}$

1. Coefficient of performance of Carnot refrigeration cycle

We know that coefficient of performance of Carnot refrigeration cycle,

$$(\text{C.O.P.})_R = \frac{T_1}{T_2 - T_1} = \frac{270}{300 - 270} = 9 \quad (\text{Ans})$$

2. Work required per second

Let $W_R =$ work required per second.

Heat absorbed at 270° K (T_1)

$Q_1 = 1130 \text{ KJ/min} = 18.83 \text{ KJ/s}$

We know that $(\text{C.O.P.})_R = \frac{Q_1}{W_R}$ or $9 = \frac{18.83}{W_R}$

$$\therefore W_R = 2.1 \text{ KJ/s or } 2.1 \text{ KW} \quad (\text{Ans})$$

3. Coefficient of performance of Carnot heat pump.

We know that coefficient of performance of a Carnot heat pump,

$$(\text{C.O.P.})_P = \frac{T_2}{T_2 - T_1} = \frac{300}{300 - 270} = 10 \quad (\text{Ans})$$

4. Heat delivered by heat pump at 300°K

Let $Q_2 =$ Heat delivered by heat pump at 300°K.

Heat absorbed at (T_1),

$Q_1 = 1130 \text{ KJ/min}$

We know that

$$(\text{C.O.P.})_P = \frac{Q_2}{Q_2 - Q_1} = \text{OR } 10 = \frac{Q_2}{Q_2 - 1130}$$

$$\therefore 10 Q_2 - 11300 = Q_2 \text{ or } Q_2 = 1256 \text{ KJ/min} \quad (\text{Ans})$$

Example -

A cold storage is to be maintained at -5°C while the surroundings are at 35°C. The heat leakage from the surroundings into the cold storage is estimated to be 29kW. The actual C.O.P. of the refrigeration plant is one – third of an ideal plant working between the same temperatures. Find the power required to drive the plant.

Solution -

Given:- $T_1 = -5^\circ \text{C} = -5 + 273 = 268^\circ \text{K}$; $T_2 = 35^\circ \text{C} = 35 + 273 = 308^\circ \text{K}$;

$$Q_1 = 29 \text{ kW}; (\text{C.O.P.})_{\text{actual}} = \frac{1}{3} (\text{C.O.P.})_{\text{ideal}}$$

The refrigerating plant operating between the temperatures T_1 and T_2 .

Let W_R = Work or power required to drive the plant.

We know that the coefficient of performance of an ideal refrigeration plant,

$$(\text{C.O.P.})_{\text{ideal}} = \frac{T_2}{T_2 - T_1} = \frac{308}{308 - 268} = 6.7$$

∴ Actual coefficient of performance,

$$(\text{C.O.P.})_{\text{actual}} = \frac{1}{3} (\text{C.O.P.})_{\text{ideal}} = \frac{1}{3} \times 6.7 = 2.233$$

We also know that $(\text{C.O.P.})_{\text{actual}} = \frac{Q_1}{W_R}$

$$W_R = \frac{Q_1}{(\text{C.O.P.})_{\text{actual}}} = \frac{29}{2.233} = 12.987 \text{ Kw} \quad (\text{Ans})$$

Example -

1.5 kW per tonne of refrigeration is required to maintain the temperature of -40°C in the refrigerator. If the refrigeration cycle works on Carnot cycle, determine the following:

1. C.O.P. of the cycle;
2. Temperature of the sink;
3. Heat rejected to the sink per tonne of refrigerator;
4. Heat supplied and E.P.R., if the cycle is used as a heat pump.

Solution-

Given: $W_R = 1.5 \text{ kW}$; $Q_1 = 1 \text{ TR}$; $T_1 = -40^\circ\text{C} = -40 + 273 = 233^\circ\text{K}$

1. C.O.P. of the cycle

Since 1.5 kW per tonne of refrigeration is required to maintain the temperature in the refrigerator, therefore amount of work required to be done,

$$W_R = 1.5 \text{ kW} = 1.5 \text{ kJ/s} = 1.5 \times 60 = 90 \text{ kJ/min}$$

And heat extracted from the cold body,

$$Q_1 = 1 \text{ TR} = 210 \text{ kJ/min}$$

$$\text{We know that } (\text{C.O.P.})_R = \frac{Q_1}{W_R} = \frac{210}{90} = 2.33 \quad (\text{Ans})$$

1. Temperature of the sink

Let T_2 = Temperature of sink.

$$\text{We know that } (\text{C.O.P.})_R = \frac{T_2}{T_2 - T_1} \text{ or } 2.33 = \frac{233}{T_2 - 233}$$

$$\therefore T_2 = \frac{233}{2.33} + 233 = 333 \text{ K} = 60^\circ\text{C} \quad (\text{Ans})$$

2. Heat rejected to the sink per tonne of refrigeration

We know that heat rejected to the sink,

$$Q_2 = Q_1 + W_R = 210 + 90 = 300 \text{ kJ/min}$$

3. Heat supplied and E.P.R., if the cycle is used as a heat pump.

We know that heat supplied when the cycle is used as a heat pump is

$$Q_2 = 300 \text{ kJ/min} \quad (\text{Ans})$$

$$\text{And } \text{E.P.R.} = (\text{C.O.P.})_R + 1 = 2.33 + 1 = 3.33 \quad (\text{Ans})$$

Example-:

The capacity of a refrigerator is 200 TR when working between -6°C and 25°C . Determine the mass of ice produced per day from water at 25°C . Also find the power required to drive the unit. Assume that the cycle operates on reversed Carnot cycle and latent heat of ice is 335 kJ/kg .

Solution . Given: $Q = 200 \text{ TR}$; $T_1 = -6^{\circ}\text{C} = -6 + 273 = 267^{\circ}\text{K}$

$T_2 = 25^{\circ}\text{C} = 25 + 273 = 298 \text{ K}$; $h_{fg(\text{ice})} = 335 \text{ kJ/kg}$

Mass of ice produced per day

We know that heat extraction capacity of the refrigerator

$$= 200 \times 210 = 42000 \text{ kJ/min} \quad \dots (\text{1 TR} = 210 \text{ kJ/min})$$

And heat removed from 1 kg of water at 25°C to form ice at 0°C

$$= \text{mass} \times \text{Sp. Heat} \times \text{Rise in temperature} + h_{fg(\text{ice})}$$

$$= 1 \times 4.187(25-0) + 335 = 439.7 \text{ kJ/kg}$$

∴ Mass of ice produced per min

$$= \frac{42000}{439.7} = 95.52 \text{ kg/min}$$

And mass of ice produced per day

$$= 95.52 \times 60 \times 24 = 137550 \text{ kg} = 137.55 \text{ tonnes} \quad (\text{Ans})$$

Power required to drive the unit

We know that C.O.P. of the reversed Carnot cycle

$$= \frac{T_1}{T_2 - T_1} = \frac{267}{298 - 267} = 8.6$$

Also C.O.P. = $\frac{\text{Heat Extraction Capacity}}{\text{Work Done}}$

$$\therefore 8.6 = \frac{42000}{\text{Work done per min}}$$

Or Work done per min = $42000 / 8.6 = 4884 \text{ kJ/min}$

∴ Power required to drive the unit = $4884 / 60 = 81.4 \text{ Kw}$ (Ans)

Example -:

A cold storage plant is required to store 20 tonnes of fish. The fish is supplied at a temperature of 30°C . The specific heat of fish above freezing point is 2.93 kJ/kg K . The specific heat of fish below freezing point is 1.26 kJ/kg K . The fish is stored in cold storage which is maintained at -8°C . The freezing point of fish is -4°C . The latent heat of fish is 235 kJ/kg . If the plant requires 75 kW to drive it, find:

1. The capacity of plant and
2. Time taken to achieve cooling.

Assume actual C.O.P. of the plant as 0.3 of the Carnot C.O.P.

Solution -:

Given: $m = 20 \text{ t} = 20,000 \text{ kg}$; $T_2 = 30^{\circ}\text{C} = 30 + 273 = 303^{\circ}\text{K}$;

$c_{AF} = 2.93 \text{ kJ/kg}^{\circ}\text{K}$; $c_{BF} = 1.26 \text{ kJ/kg}^{\circ}\text{K}$; $T_1 = -8^{\circ}\text{C} = -8 + 273 = 265^{\circ}\text{K}$;

$T_3 = -4^{\circ}\text{C} = -4 + 273 = 269^{\circ}\text{K}$ $h_{fg(\text{Fish})} = 235 \text{ kJ/kg}$; $P = 75 \text{ kJ/s}$

- Capacity of the plant

We know that Carnot C.O.P.

$$= \frac{T_1}{T_2 - T_1} = \frac{265}{303 - 265} = 6.97$$

∴ Actual C.O.P. = $0.3 \times 6.97 = 2.091$

And heat removed by the plant

$$= \text{Actual C.O.P.} \times \text{Work required}$$

$$= 2.091 \times 75 = 156.8 \text{ kJ/s} = 156.8 \times 60 = 9408 \text{ kJ/min}$$

∴ Capacity of the plant

$$= 9408 / 210 = 44.8 \text{ TR} \quad (\text{1 TR} = 210 \text{ kJ/min}) \quad (\text{ans})$$

- Time taken to achieve cooling

We know that heat removed from the fish above freezing point,

$$Q_1 = m \times c_{AF} (T_2 - T_3)$$

$$= 20000 \times 2.93(303-269) = 1.992 \times 10^6 \text{ kJ}$$

Similarly, heat removed from the fish below freezing point,

$$Q_2 = m \times c_{BF} (T_3 - T_1)$$

$$= 20000 \times 1.26 (269-265) = 0.101 \times 10^6 \text{ kJ}$$

And total latent heat of fish,

$$Q_3 = m \times h_{fg} (\text{Fish}) = 20000 \times 235 = 4.7 \times 10^6 \text{ kJ}$$

∴ Total heat removed by the plant

$$= Q_1 + Q_2 + Q_3$$

$$= 1.992 \times 10^6 + 0.101 \times 10^6 + 4.7 \times 10^6 = 6.793 \times 10^6 \text{ kJ}$$

And time taken to achieve cooling

$$= \frac{\text{Total heat removed by the plant}}{\text{Heat removed by the plant per min}} = \frac{6.793 \times 10^6}{9408} = 722 \text{ min}$$

$$= 12.03 \text{ h}$$

(Ans)

SIMPLE VAPOUR COMPRESSION REFRIGERATION SYSTEMS.**INTRODUCTION:-**

A vapour compression refrigeration system is an improved type of air refrigeration system in which a suitable working substance, termed as refrigerant, is used. It condenses and evaporates at temperatures and pressures close to the atmospheric conditions. The refrigerants, usually, used for this purpose are ammonia (NH_3), carbon dioxide (CO_2) and sulphur dioxide (SO_2).

FIG

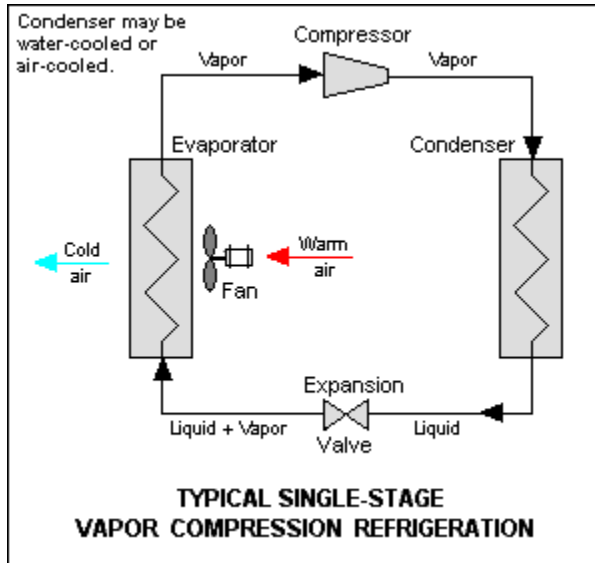
**ADVANTAGES AND DISADVANTAGES OF VAPOUR COMPRESSION REFRIGERATION SYSTEM OVER AIR REFRIGERATION SYSTEM.**

Following are the advantages and disadvantages of the vapour compression refrigeration system over air refrigeration system.

Advantages

1. It has smaller size for the given capacity of refrigeration.
2. It has less running cost.
3. It can be employed over a large range of temperatures.
4. The coefficient of performance is quite high.

Disadvantages

1. The initial cost is high.
2. The prevention of leakage of the refrigerant is the major problem in vapour compression system.

Fig shows the schematic diagram of a simple vapour compression refrigeration system. It consists of the following five essential parts.

1. Compressor. The low pressure and temperature vapour refrigerant from evaporator is drawn into the compressor through the inlet or suction valve A, where it is compressed to a high pressure and temperature. This high pressure and temperature vapour refrigerant is discharged into the condenser through the delivery or discharge valve B.
2. Condenser. The condenser or cooler consists coils of pipe in which the high pressure and temperature vapour refrigerant is cooled and condensed. The refrigerant, while passing through the condenser, gives up its latent heat to the surrounding condensing medium which is normally air or water.
3. Receiver. The condensed liquid refrigerant from the condenser is stored in a vessel known as receiver from where it is supplied to the evaporator through the expansion valve or refrigerant control valve.
4. Expansion valve. It is also called throttle valve or refrigerant control valve. The function of the expansion valve is to allow the liquid refrigerant under high pressure and temperature to pass at a controlled rate after reducing its pressure and temperature. Some of the liquid refrigerant evaporates as it passes through the expansion valve, but the greater portion is vaporized in the evaporator at the low pressure and temperature.
5. Evaporator. An evaporator consists of coils of pipe in which the liquid-vapour refrigerant at low pressure and temperature is evaporated and changed into vapour refrigerant at low pressure and temperature. In evaporating, the liquid vapour refrigerant absorbs its latent heat of vaporization from the medium (air, water or brine) which is to be cooled.

Q. In an ammonia vapour compression system, the pressure in the evaporator is 2bar. Ammonia at exit is 0.85 dry and at entry its dryness fraction is 0.19 during compression, the work done per kg of ammonia is 150kJ. Calculate the C.O.P. and the volume of vapour entering the compressor per minute, if the rate of ammonia circulation is 4.5 kg/min. The latent heat and specific volume at 2 bar are 1325 kJ/kg and 0.58 m³/kg respectively.

Solution-

Given: $p_1=p_4=2$ bar; $x_1=0.85$; $x_4=0.19$; $w=150$ kJ/kg; $m_a=4.5$ kg/min;
 $h_{fg}=1325$ kJ/kg; $v_g=0.58$ m³/kg

C.O.P.

The T-s and p-h diagram are shown in figure ----

Since the ammonia vapour at entry to the evaporator has dryness fraction(x_4) equal to 0.19, therefore enthalpy at point 4.

$$h_4 = x_4 \times h_{fg} = 0.19 \times 1325 = 251.75 \text{ kJ/kg}$$

Similarly, enthalpy of ammonia vapour at exit at point 1,

$$h_1 = x_1 \times h_{fg} = 0.85 \times 1325 = 1126.25 \text{ kJ/kg}$$

• Heat extracted from the evaporator or refrigerating effect,

$$R_E = h_1 - h_4 = 1126.25 - 251.75 = 874.5 \text{ kJ/kg}$$

We know that work done during compression,

$$W = 150 \text{ kJ/kg}$$

$$\therefore \text{C.O.P.} = R_E/w = 874.5/150 = 5.83 \quad (\text{Ans})$$

Volume of vapour entering the compressor per minute

We know that volume of vapour entering the compressor per minute

$$= \text{Mass of refrigerant / min} \times \text{Specific volume}$$

$$= m_a \times v_g = 4.5 \times 0.85 = 2.61 \text{ m}^3/\text{min} \quad (\text{Ans})$$

- Q.** The temperature limits of an ammonia refrigerating system are 25°C and -10°C . If the gas is dry at the end of compression, calculate the coefficient of performance of the cycle assuming no under-cooling of the liquid ammonia. Use the following table for properties of ammonia:

Temperature($^\circ\text{C}$)	Liquid heat (KJ/kg)	Latent heat (KJ/Kg)	Liquid entropy (KJ/Kg K)
25	298.9	1166.94	1.1242
-10	135.37	1297.68	0.5443

Solution-

Given: $T_2 = T_3 = 25^\circ\text{C} = 25+273=298 \text{ K}$; $T_1=T_4 = -10^\circ\text{C} = 263 \text{ K}$;

$$h_{f3} = h_4 = 298.9 \text{ KJ/Kg}; s_{f2} = 1.1242 \text{ KJ/ Kg K}; h_{f1} = 135.37 \text{ KJ/Kg};$$

$$h_{fg1} = 1297.68 \text{ KJ/Kg}; s_{f1} = 0.5443 \text{ KJ/Kg K}; h_{fg2} = 1166.94 \text{ KJ/Kg}$$

The T-S and p-h diagrams are shown in fig.

Let $x_1 =$ Dryness fraction at point 1.

We know that entropy at point 1,

$$S_1 = s_{f1} + x_1 h_{fg1}/T_1 = 0.5443 + \frac{x_1 h_{fg1}}{T_1}$$

$$= 0.5443 + \frac{x_1 \times 1297.68}{263} = 0.5443 + 4.934x_1 \quad \dots (i)$$

Similarly, entropy at point 2,

$$S_2 = s_{f2} + \frac{h_{fg2}}{T_2} = 0.5443 + \frac{1166.94}{298} = 5.04 \quad \dots (ii)$$

Since the entropy at point 1 is equal to entropy at point 2, therefore equating (i) and (ii),

$$0.5443 + 4.934 x_1 \quad \text{or} \quad x_1 = 0.91$$

We know that the enthalpy at 1,

$$h_1 = h_{f1} + x_1 h_{fg1} = 135.37 + 0.91 \times 1297.68 = 1316.26 \text{ kJ/kg}$$

and enthalpy at point 2,

$$h_2 = h_{f2} + h_{fg2} = 298.9 + 1166.94 = 1465.84 \text{ kJ/kg}$$

\therefore Coefficient of performance of the cycle

$$= \frac{h_1 - h_{f3}}{h_2 - h_1} = \frac{1316.26 - 298.9}{1465.84 - 1316.26} = 6.8 \quad (\text{Ans})$$

- Q.** A vapour compression refrigerator works between the pressure limits of 60 bar and 25 bar. The working fluid is just dry at the end of compression and there is no under cooling of the liquid before the expansion valve. Determine: 1. C.O.P. of the cycle; and 2. Capacity of the refrigerator if the fluid flow is at the rate of 5 kg/min.

Data:

Pressure	Saturation	Enthalpy (kJ/kg)	Entropy (kJ/kg K)
----------	------------	------------------	-------------------

(bar)	Temperature (°K)	Liquid	Vapour	Liquid	Vapour
60	295	151.96	293.29	0.554	1.0332
25	261	56.32	322.58	0.226	1.2464

Solution-

Given: $p_2 = p_3 = 60$ bar; $p_1 = p_4 = 25$ bar; $T_2 = T_3 = 295$ K
 $T_1 = T_4 = 261$ K; $h_{f3} = h_4 = 151.96$ kJ/kg; $h_{f1} = 56.32$ kJ/kg;
 $h_{g2} = h_2 = 293.29$ kJ/kg; $h_{g1} = 322.58$ kJ/kg; $s_{f2} = 0.554$ kJ/kg K ;
 $s_{f1} = 0.226$ kJ/kg K; $s_{g2} = 1.0332$ kJ/kg K; $s_{g1} = 1.2464$ kJ/kg K

- C.O.P. of the cycle

The T-S and p-h diagrams are shown

Let $x_1 =$ Dryness fraction of the vapour refrigerant entering the compressor at point 1.

We know that entropy at point 1,

$$S_1 = s_{f1} + x_1 s_{fg1} = s_{f1} + x_1 (s_{g1} - s_{f1}) \dots \quad (* S_{g1} = s_{f1} + s_{fg1})$$

$$= 0.226 + x_1 (1.2464 - 0.226) = 0.226 + 1.0204 x_1 \quad \dots (i)$$

And entropy at point 2, $s_2 = 1.0332$ kJ/kg K ... (ii)

Since the entropy at point 1 is equal to entropy at point 2, therefore equating equations (i) and (ii),

$$0.226 + 1.0204 x_1 = 1.0332 \quad \text{or } x_1 = 0.791$$

We know that enthalpy at point 1,

$$h_1 = h_{f1} + x_1 h_{fg1} = h_{f1} + x_1 (h_{g1} - h_{f1}) \quad \dots \quad (* h_{g1} = h_{f1} + h_{fg1})$$

$$= 56.32 + 0.791 (322.58 - 56.32) = 266.93 \text{ kJ/kg}$$

- C.O.P. of the cycle

$$= \frac{h_1 - h_{f3}}{h_2 - h_1} = \frac{266.93 - 151.96}{293.29 - 266.93} = 4.36 \quad (\text{Ans})$$

- Capacity of the refrigerator

We know that the heat extracted or refrigerating effect produced per kg of refrigerant

$$= h_1 - h_{f3} = 266.93 - 151.93 = 114.97 \text{ kJ/kg}$$

Since the fluid flow is at the rate of 5 kg/min, therefore total heat extracted

$$= 5 \times 114.97 = 574.85 \text{ kJ/min}$$

- Capacity of the refrigerator

$$= \frac{574.85}{210} = 2.74 \text{ TR} \quad (\text{Ans}) \quad \dots \quad (* \text{TR} = 210 \text{ kJ/min})$$

Q. Find the theoretical C.O.P. for a CO_2 machine working between the temperature range of 25°C and -5°C . The dryness fraction of CO_2 gas during the suction stroke is 0.6; the following properties of CO_2 are given:

Data:

Temperature °C	Liquid		Vapour		Latent heat KJ/kg
	Enthalpy kJ/kg	Entropy kJ/kg	Enthalpy kJ/kg	Entropy kJ/kg	
25	164.77	0.5978	282.23	0.9918	117.46
-5	72.57	0.2862	321.33	1.2146	248.76

Solution –

Given : $T_2 = T_3 = 25^\circ\text{C} = 25 + 273 + 298^\circ\text{K}$;
 $T_1 = T_4 = -5^\circ\text{C} = -5 + 273 = 268\text{ K}$; $x_1 = 0.6$; $h_{f3} = h_{f2} = 164.77\text{ kJ/kg}$;
 $h_{f1} = h_{f4} = 72.57\text{ kJ/kg}$; $s_{f2} = 0.5978\text{ kJ/kg}^\circ\text{K}$; $s_{f1} = 0.2862\text{ kJ/kg}^\circ\text{K}$;
 $h'_{2} = 282.23\text{ kJ/kg}$; $h'_{1} = 321.33\text{ kJ/kg}$; $s'_{2} = 0.9918\text{ kJ/kg}^\circ\text{K}$;
 $s'_{1} = 1.2146\text{ kJ/kg}^\circ\text{K}$; $h_{fg2} = 117.46\text{ kJ/kg}$; $h_{fg1} = 248.76\text{ kJ/kg}$

The T-s and p-h diagrams are shown

First of all, let us find the dryness fraction at point 2, (x_2). We know that the entropy at point 1,

$$s_1 = s_{f1} + \frac{x_1 h_{fg1}}{T_1} = 0.2862 + \frac{0.6 \times 248.76}{268} = 0.8431 \quad \dots (i)$$

Similarly, entropy at point 2,

$$s_2 = s_{f2} + \frac{x_2 h_{fg2}}{T_2} = 0.5978 + \frac{x_2 \times 117.46}{298}$$

$$= 0.5978 + 0.3941 x_2$$

Since the entropy at point 1 (s_1) is equal to entropy at point 2 (s_2), therefore equating equation (i) and (ii),

$$0.8431 = 0.5978 + 0.3941 x_2 \quad \text{or} \quad x_2 = 0.622$$

We know that enthalpy at point 1,

$$h_1 = h_{f1} + x_1 h_{fg1} = 72.57 + 0.6 \times 248.76 = 221.83\text{ kJ/kg};$$

and enthalpy at point 2, $h_2 = h_{f2} + x_2 h_{fg2} = 164.77 + 0.622 \times 117.46 = 237.83\text{ kJ/kg}$

• Theoretical C.O.P.

$$= \frac{h_1 - h_{f3}}{h_2 - h_1} = \frac{221.83 - 164.77}{237.83 - 221.83} = \frac{57.06}{16} = 3.57 \quad (\text{Ans})$$

Introduction-:

The vapour absorption system uses heat energy, instead of mechanical energy as in vapour compression systems, in order to change the conditions of the refrigerant required for the operation of the refrigeration cycle.

In the vapour absorption system, the compressor is replaced by absorber, a pump, a generator and a pressure reducing valve.

Simple vapour absorption system-:

FIG

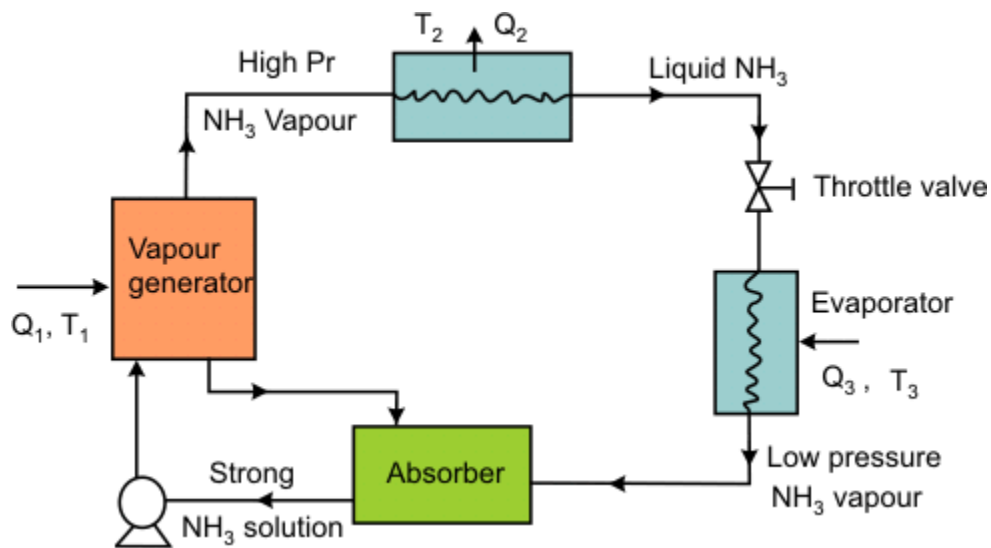

The simple vapour absorption system, as shown in figure, consists of an absorber, a pump, a generator and a pressure reducing valve to replace the compressor of vapour compression system. The other components of the system are condenser, receiver, expansion valve and evaporator as in the vapour compression system.

In this system, the low pressure ammonia vapour leaving the evaporator, enters the absorber where it is absorbed by the cold water in the absorber. The water has the ability to absorb very large quantities of ammonia vapour and the solution thus formed, is known as aqua-ammonia. The absorption of ammonia vapour in water lowers the

pressure in the absorber which in turn draws more ammonia vapour from the evaporator and thus raises the temperature of solution.

The strong solution of ammonia in the generator is heated by some external source such as gas or steam. During the heating process, the ammonia vapour is driven off the solution at high pressure leaving behind the hot weak ammonia solution in the generator. This weak ammonia solution flows back to the absorber at low pressure after passing through the pressure reducing valve. The high pressure ammonia vapour from the generator is condensed in the condenser to a high pressure liquid ammonia. This liquid ammonia is passed to the expansion valve through the receiver and then to the evaporator. This completes the simple vapour absorption cycle.

Practical vapour absorption system:-

These accessories help to improve the performance and working of the plant, as discussed below:-

1. **Analyser:** When ammonia is vaporized in the generator, some water is also vaporized and will flow into the condenser along with the ammonia vapour in the simple system. If these unwanted water particles are not removed before entering into the condenser, they will enter into the expansion valve where they freeze and choke the pipe line. In order to remove these unwanted particles flowing to the condenser, an analyser is used.
2. **Rectifier:** In case the water vapours are not completely removed in the analyser, a closed type vapour cooler called rectifier (also known as dehydrator) is used. It is generally water cooled and may be of the double pipe, shell and coil or shell and tube type. Its function is to cool further the ammonia vapours leaving the analyser so that the remaining water vapours are condensed.
3. **Heat exchangers:** The heat exchanger provided between the pump and the generator is used to cool the weak hot solution returning from the generator to the absorber.

Advantages of vapour absorption refrigeration system over vapour compression refrigeration system.

1. In the vapour absorption system, the only moving part of the entire system is a pump which has a small motor. thus, the operation of this system is essentially quiet and is subjected to little wear. The vapour compression system of the same capacity has more wear, tear and noise due to moving parts of the compressor.
2. The vapour absorption system uses heat energy to change the condition of the refrigerant from the evaporator. The vapour compression system uses mechanical energy to change the condition of the refrigerant from the evaporator.
3. The vapour absorption systems are usually designed to use steam, either at high pressure or low pressure. The exhaust steam from furnaces and solar energy may also be used. Thus this system can be used where the electric power is difficult to obtain or is very expensive.
4. The load variations does not effect the performance of a vapour absorption system. The load variations are met by controlling the quantity of aqua circulated and the quantity of steam supplied to the generator.
The performance of a vapour compression system at partial loads is poor.

DOMESTIC ELECTROLUX (Ammonia Hydrogen) REFRIGERATOR.

FIG

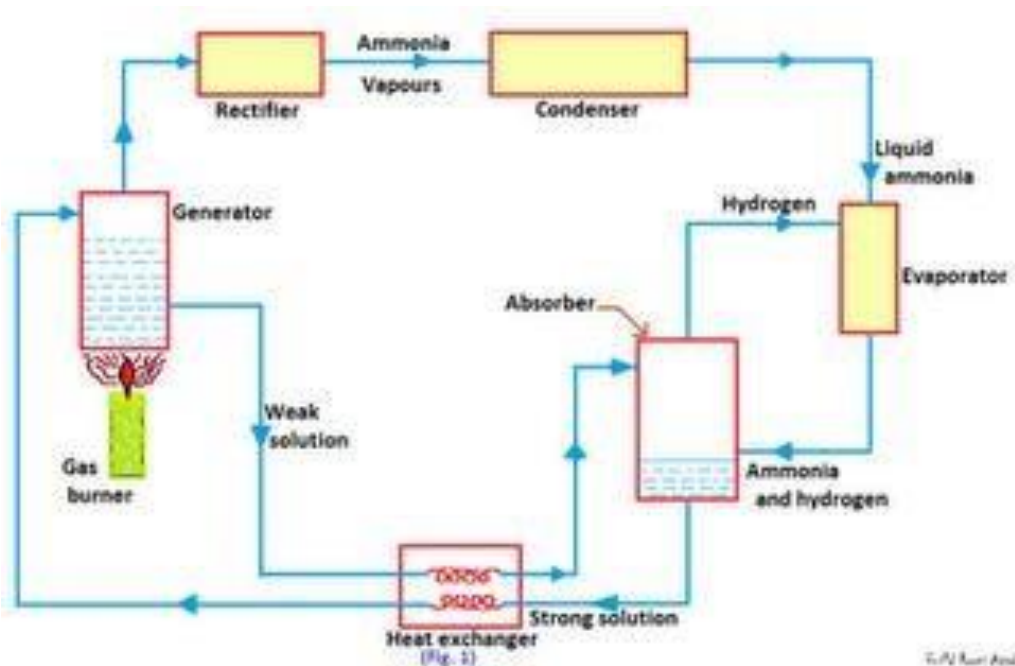

The domestic absorption type refrigerator was invented by two Swedish engineers Carl Munters and Baltzer Von Platan in 1925.

This type of refrigerator is also called three-fluid absorption system. The main purpose of this system is to eliminate the pump so that in the absence of moving parts, the machine becomes noise-less. The three fluids used in this system are ammonia, hydrogen and water. The ammonia is used as a refrigerant because it possesses most of the desirable properties. It is toxic, but due to absence of moving parts, there is very little changes for the leakage and the total amount of refrigeration used is small. The water is used as a solvent because it has the ability to absorb ammonia readily. The principle of operation of a domestic Electrolux type refrigerator, as shown in figure is discussed below.

The strong ammonia solution from the absorber through heat exchanger is heated in the generator by applying heat from an external source usually a gas burner. During this heating process, ammonia vapours are removed from the solution and passed to the condenser. A rectifier or a water separator fitted before the condenser

removes water vapour carried with the ammonia vapours, so that dry ammonia vapours are supplied to the condenser.

The ammonia vapours in the condenser are condensed by using external cooling source the liquid refrigerant leaving the condenser flows under gravity to the evaporator where it meets the hydrogen gas. The hydrogen gas which is being fed to the evaporator permits the liquid ammonia to evaporate at a low pressure and temperature according to Dalton's principle. During the process of evaporation, the ammonia absorbs latent heat from the refrigerated space and thus produces cooling effect.

REFRIGERANT COMPRESSORS.**Introduction -**

A refrigerant compressor, as the name indicates, is a machine used to compress the vapour refrigerant from the evaporator and to raise its pressure so that the corresponding saturation temperature is higher than that of the cooling medium.

Classification of compressors:-

1. According to the method of compression
 - (a) Reciprocating compressors,
 - (b) Rotary compressors, and
 - Centrifugal compressors,
2. According to the number of working strokes
 - (a) Single acting compressors, and
 - (b) Double acting compressors.
3. According to the number of stages
 - (a) Single stage (or single cylinder) compressors, and
 - (b) Multi-stage (or multi-cylinder) compressors.

RECIPROCATING COMPRESSORS-

The compressors in which the vapor refrigerant is compressed by reciprocating (back and forth) motion of the piston, are called reciprocating compressors. These compressors are used for refrigerants which have comparatively low volume per kg and a large differential pressure, such as ammonia (R-717), R-12, R-22, and methyl chloride (R-40). The reciprocating compressors are available in sizes as small as 1/12 kW which are used in small domestic refrigerators and up to about 150 kW for large capacity installations.

When the piston moves downward (during suction stroke) as shown, the refrigerant left in the clearance space expands. Thus the volume of the cylinder (above the piston) increases and the pressure inside the cylinder decreases. When the pressure becomes slightly less than the suction pressure or atmospheric pressure the suction valve gets opened and the vapour refrigerant flows into the cylinder.

When the pressure inside the cylinder becomes greater than that on the top of the discharge valve, the discharge valve gets opened and the vapour refrigerant is discharged into the condenser and the cycle is repeated.

ROTARY COMPRESSORS-

In rotary compressors, the vapour refrigerant from the evaporator is compressed due to the movement of blades. The rotary compressors are positive displacement type compressors. Since the clearance in rotary compressors is negligible, therefore they have high volumetric efficiency. These compressors may be used with refrigerants R-12, R-22, R-114 and ammonia.

1. Single stationary blade type rotary compressor. A single stationary blade type rotary compressor is shown in figure. This consists of a stationary cylinder, a roller (or impeller) and a shaft. The shaft has an eccentric on which the roller is mounted. A blade is set into slot of a cylinder in such a manner that it always maintains contacts with the roller by means of a spring. The blade moves in and out of the slot to follow the rotor when it rotates. Since the blade separates the suction and discharge ports as shown.

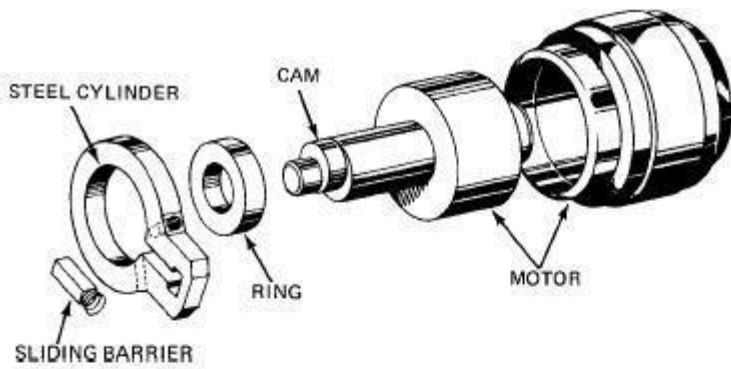

Figure 9-71 Parts of a rotary compressor. (Courtesy of General Motors.)

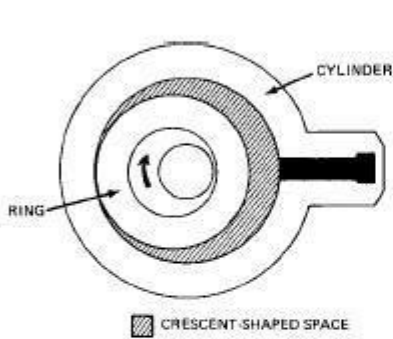

Figure 9-72 Operation of a rotary compressor. (Courtesy of General Motors.)

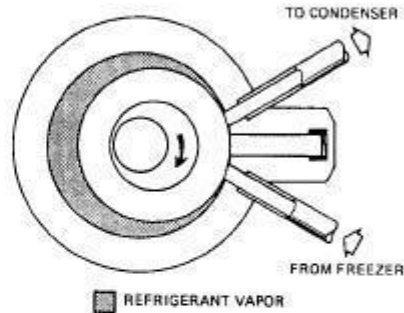

Figure 9-73 Beginning of the compression phase of a rotary compressor. (Courtesy of General Motors.)

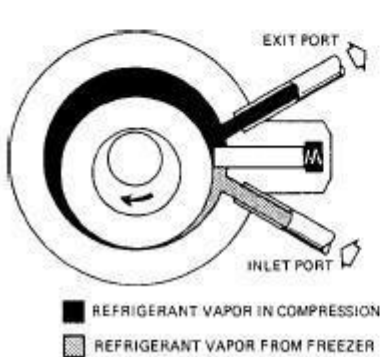

Figure 9-74 Beginning of the intake phase in a rotary compressor. (Courtesy of General Motors.)

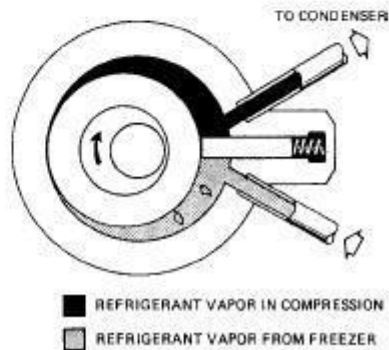

Figure 9-75 Compression and intake phases half completed in a rotary compressor. (Courtesy of General Motors.)

CENTRIFUGAL COMPRESSORS.

A single stage centrifugal compressor, in its simplest form, consists of an impeller to which a number of curved vanes are fitted symmetrically, as shown in figure. The impeller rotates in an air tight volute casing with inlet and outlet points.

The impeller draws in low pressure vapour refrigerant from the evaporator. When the impeller rotates, it pushes the vapour refrigerant from the centre of the impeller to its periphery by centrifugal force.

CONDENSERS.

Introduction.

The condenser is an important device used in the high pressure side of a refrigeration system. Its function is to remove heat of the hot vapour refrigerant discharged from the compressor.

Classification of condensers.

According to the condensing medium used, the condensers are classified into the following three groups:

1. Air cooled condensers,
2. Water cooled condensers, and
3. Evaporative condensers.

These condensers are discussed, in detail, in the following pages.

Air cooled condensers:-

An air-cooled condenser is one in which the removal of heat is done by air. It consists of steel or copper tubing through which the refrigerant flows. The size of tube usually ranges from 6 mm to 18 mm outside diameter, depending upon the size of condenser. Generally copper tubes are used because of its excellent heat transfer ability. The condensers with steel tubes are used in ammonia refrigerating systems. The tubes are usually provided with plate type fins to increase the surface area for heat transfer, as shown in figure.

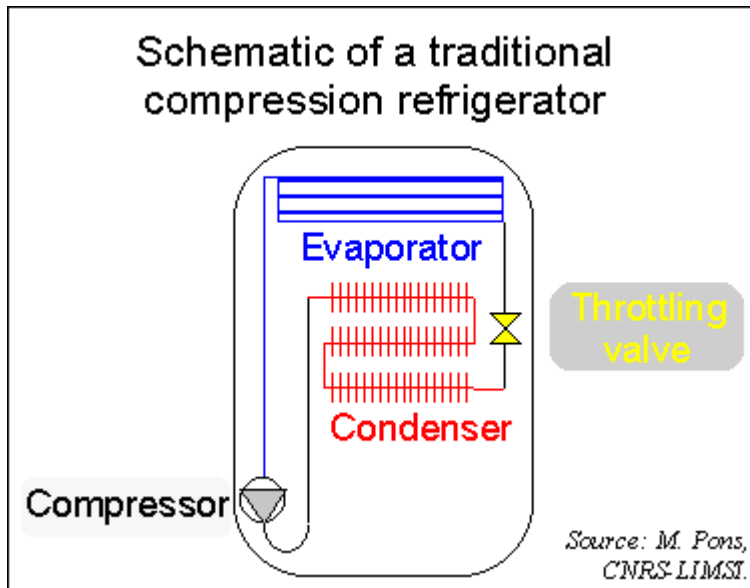
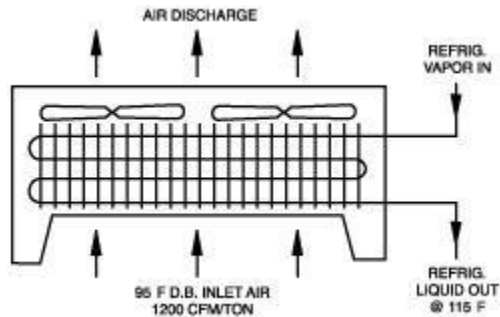

Water cooled condensers:-

A water cooled condenser is one in which water is used as the condensing medium. They are always preferred where an adequate supply of clear inexpensive water and means of water disposal are available. These condensers are commonly used in commercial and industrial refrigerating units. The water cooled condensers may use either of the following two water systems.

1. Waste water system or
2. Recirculated water system.

In a waste water system, the water after circulating in the condenser is discharged to a sewer.

In a recirculated water system as shown in figure, the same water circulating in the condenser is cooled and used again and again.

EVAPORATIVE CONDENSERS-

The evaporating condensers, as shown in figure, use both air and water as condensing mediums to condense the hot vapour refrigerant to liquid refrigerant. These condensers perform the combined functions of a water cooled condenser and a cooling tower. In its operation, the water is pumped from the sump to a spray header and sprayed through nozzles over the condenser coils through which the hot vapour refrigerant from the compressor is passing. The heat transfers from the refrigerant through the condensing tube walls and into the water that is wetting the outside surface of the tubes.

The cold water that drops down into a sump is recirculated. In order to make up the deficiency caused by the evaporated water, additional water is supplied to the sump.

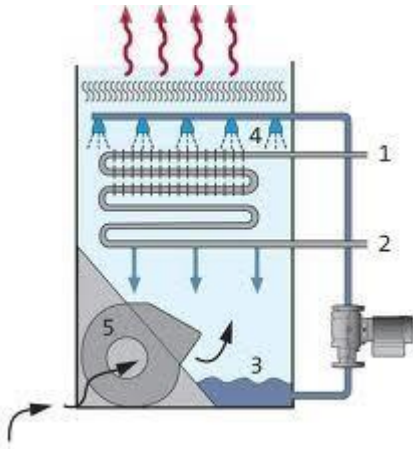

EVAOPRATORS-

Introduction :-

The evaporator is an important device used in the low pressure side of a refrigeration system. The liquid refrigerant from the expansion valve enters into the evaporator where it boils and changes into vapour.

Types of evaporators.

Through there are many types of evaporators, yet the following are important from the subject point of view:

1. According to the type of construction.
 - (a) Bare tube coil evaporator,
 - (b) Finned tube coil evaporator,
 - (c) Plate evaporator,
 - (d) Shell and tube evaporator,
 - (e) Shell and coil evaporator, and
 - (f) Tube-in-tube evaporator,
2. According to the mode of heat transfer
 - (a) Natural convection evaporator, and
 - (b) Forced convection evaporator.

Bare tube coil evaporators-:

The simplest type of evaporator is the bare tube coil evaporator, as shown in figure.

The bare tube coil evaporators are also known as prime-surface evaporators. Because of its simple construction, the bare tube coil is easy to clean and defrost. A little consideration will show that this type of evaporator offers relatively little surface contact area as compared to other types of coils.

FIG

Finned evaporators-:

The metal fins are constructed of thin sheets of metal having good thermal conductivity. The shape, size or spacing of the fins can be adapted to provide best rate of heat transfer for a given application. Since the fins greatly increases the contact surfaces for heat transfer, therefore the finned evaporators are also called extended surface evaporators.

Shell and coil evaporators-:

The shell and coil evaporators, as shown in fig. , are generally dry expansion evaporators to chill water. The cooling coil is a continuous tube that can be in the form of a single or double spiral.

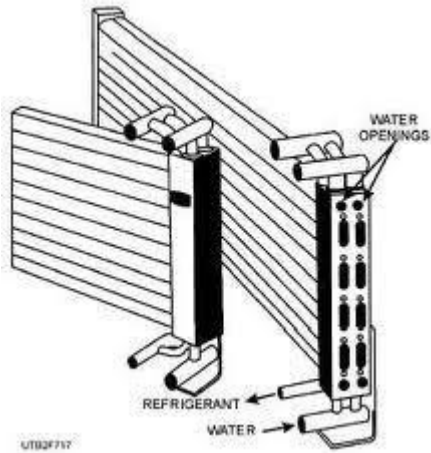

EXPANSION DEVICES.

Introduction.

The expansion device (also known as metering device or throttling device) is an important device that divides the high pressure side and the low pressure side of a refrigerating system. The expansion device performs the following functions.

1. It reduces the high pressure liquid refrigerant to low pressure liquid refrigerant before being fed to the evaporator.
2. It maintains the desired pressure difference between the high and low pressure sides of the system, so that the liquid refrigerant vaporizes at the designed pressure in the evaporator.
3. It controls the flow of refrigerant according to the load on the evaporator.

Types of expansion devices:-

Following are the main types of expansion devices used in industrial and commercial refrigeration and air conditioning system.

1. Capillary tube,
2. Hand-operated expansion valve,
3. Automatic or constant pressure expansion valve,
4. Thermostatic expansion valve,
5. Low side float valve, and
6. High side float valve.

Capillary tube:-

The capillary tube, as shown in fig., is used as an expansion device in small capacity hermetic sealed refrigeration units such as in domestic refrigerators, water coolers, room air-conditioners and freezers.

In its operation, the liquid refrigerant from the condenser enters the capillary tube. Due to the frictional resistance offered by a small diameter tube, the pressure drops. Since the frictional resistance is directly proportional to the length and inversely proportional to the diameter, therefore longer the capillary tube and smaller its inside diameter, greater is the pressure drop created in the refrigerant flow.

Automatic (or constant pressure) expansion valve:-

The automatic expansion valve is also known as constant pressure expansion valve, because it maintains constant evaporator pressure regardless of the load on the evaporator. Its main moving force is the evaporator pressure. It is used with dry expansion evaporators where the load is relatively constant.

When the compressor is running, the valve maintains an evaporator pressure in equilibrium with the spring pressure and the atmospheric pressure. The spring pressure can be varied by adjusting the tension of the spring with the help of spring adjusting screw. Once the spring is adjusted for a desired evaporator pressure, then the valve operates automatically to maintain constant evaporator pressure by controlling the flow of refrigerant to the evaporator.

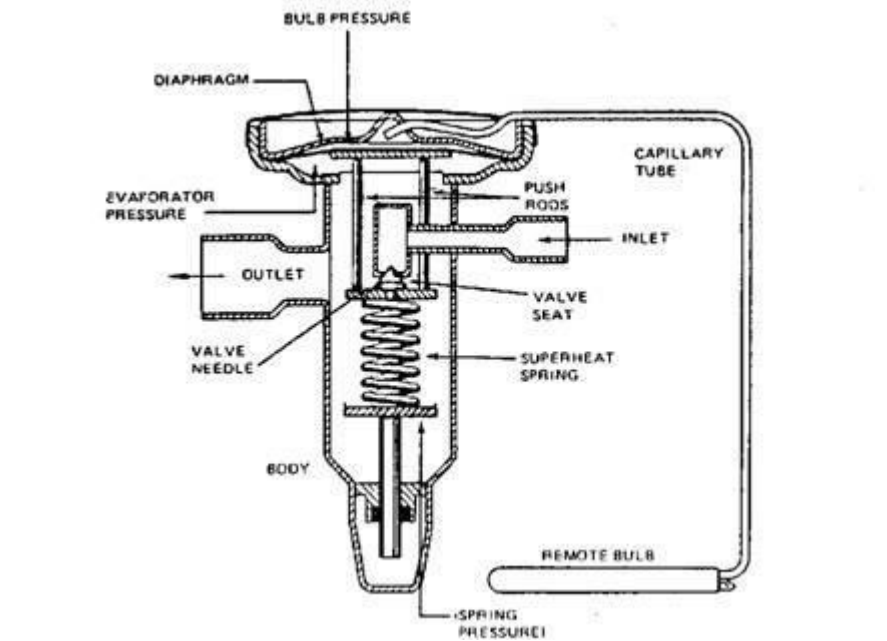

Thermostatic expansion valve:-

The thermostatic expansion valve is the most commonly used expansion device in commercial and industrial refrigeration systems. This is also called a constant superheat valve because it maintains a constant superheat of the vapour refrigerant at the end of the evaporator coil, by controlling the flow of liquid refrigerant through the evaporator.

Since the feeler bulb is installed on the suction line, therefore it will be at the same temperature as the refrigerant at that point. Any change in the temperature of the refrigerant will cause a change in pressure in the feeler bulb which will be transmitted to the top of the diaphragm. Under normal operating conditions, the feeler bulb pressure acting at the top of the diaphragm is balanced by the spring pressure and the evaporator pressure acting at the bottom of the diaphragm. The force tending to close the valve is dependent upon the spring pressure and the evaporator pressure which, in turn, depends upon the saturation temperature of the refrigerant in the evaporator coil. The force tending to open the valve depends upon the feeler bulb pressure which, in turn, depends upon the temperature of refrigerant in the bulb.

If the load on the evaporator increases, it causes the liquid refrigerant to boil faster in the evaporator coil. The temperature of the feeler bulb increases due to early vaporization of the liquid refrigerant. Thus the feeler bulb pressure increases and this pressure is transmitted through the capillary tube to the diaphragm. The diaphragm moves downwards and opens the valve to admit more quantity of liquid refrigerant to the evaporator.

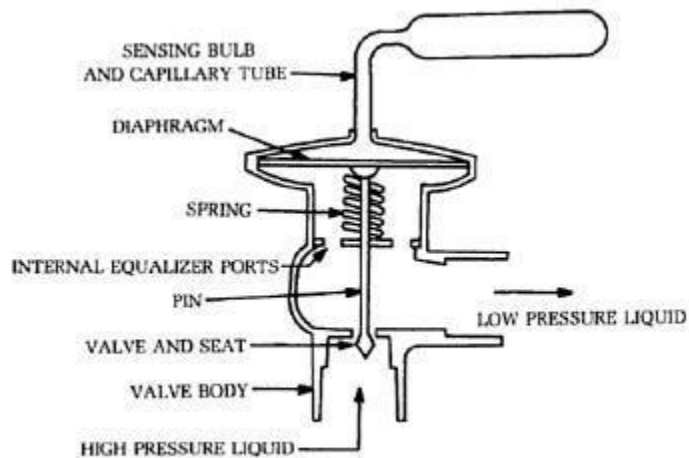

Fig. 15-13. Thermostatic expansion valve.

CH-5 REFRIGERANT FLOW CONTROLS, REFRIGERANTS & APPLICATION OF REFRIGERANTS

Introduction-:

The refrigerant is a heat carrying medium which during their cycle (compression, condensation, expansion and evaporation) in the refrigeration system absorbs heat from a low temperature system and discards the heat so absorbed to a higher temperature system.

DESIRABLE PROPERTIES OF AN IDEAL REFRIGERANT -:

We have discussed above that there is no ideal refrigerant. A refrigerant is said to be ideal if it has all of the following properties:

1. Low boiling properties,
2. High critical temperature,
3. High latent heat of vaporization,
4. Low specific heat of liquid,
5. Low specific volume of vapour,
6. Non-corrosive to metal,
7. Non-flammable and non-explosive,
8. Non-toxic,
9. Low cost,
10. Easy to liquefy at moderate pressure and temperature,
11. Easy of locating leaks by odour or suitable indicator, and
12. Mixes well with oil.

CLASSIFICATION OF REFRIGERANTS-:

The refrigerants may, broadly, be classified into the following two groups:

1. Primary refrigerants,
2. Secondary refrigerants.

The primary refrigerants are further classified into the following four groups:

1. Halo-carbon refrigerants,
2. Azeotrope refrigerants,
3. Inorganic refrigerants, and
4. Hydro-carbon refrigerants.

HALO-CARBON REFRIGERANTS-:

The American society of heating, refrigeration and air-conditioning engineers (ASHRAE) identifies 42 halo-carbon compounds as refrigerants, but only a few of them are commonly used.

Refrigerant number	Chemical name	Chemical formula
R-11	Trichloromonofluoromethane	CCl_3F
R-12	Dichlorodifluoromethane	CCl_2F_2
R-22	Monochlorodifluoromethane	CHClF_2
R-115	Monochloropentafluoroethane	CClF_2CF_3

R-11, Trichloromonofluoromethane (CCl_3F). The R-11 is a synthetic chemical which can be used as a refrigerant. It is stable, non-flammable and non-toxic. It is considered to be a low-pressure refrigerant. It has a low side pressure of 0.202 bar at -15°C and high side pressure of 1.2606 bar at 30°C . The latent heat at -15°C is 195 kJ/kg. The boiling point at atmospheric pressure is 23.77°C .

R-11 is often used by service technicians as a flushing agent for cleaning the internal parts of a refrigerator compressor when overhauling systems.

R-12, Dichlorodifluoromethane (CCl₂F₂). The R-12 is a very popular refrigerant. It is a colorless, almost odorless liquid with boiling point of -29°C at atmospheric pressure. It is non-toxic, non-corrosive, non-irritating and non-flammable. It has a relatively low latent heat value which is an advantage in small refrigerating machines.

R-22, Monochlorodifluoromethane (CHClF₂). The R-22 is a man-made refrigerant developed for refrigeration installations that need a low evaporating temperature, as in fast freezing units which maintain a temperature of -29°C to -40°C. It has also been successfully used in air conditioning units and in household refrigerators. It is used with reciprocating and centrifugal compressors.

The boiling point of R-22 is -41°C at atmospheric pressure. It has a latent heat of 216.5 kJ/kg at -15°C. The normal head pressure at 30°C is 10.88 bar.

AZEOTROPE REFRIGERANTS:-

The term 'azeotrope' refers to a stable mixture of refrigerants whose vapour and liquid phases retain identical compositions over a wide range of temperatures.

Refrigerant number	Azeotropic mixing refrigerants	Chemical formula
R-502	48.8% R-22 and 51.2% R-115	CHClF ₂ /CClF ₂ CF ₃

INORGANIC REFRIGERANTS:-

The inorganic refrigerants were exclusively used before the introduction of halocarbon refrigerants. The various inorganic refrigerants are given in the following table:

Refrigerant number	Chemical name	Chemical formula
R-717	Ammonia	NH ₃
R-729	Air	-
R-744	Carbon dioxide	CO ₂
R-764	Sulphur dioxide	SO ₂
R-118	Water	H ₂ O

R-717 (Ammonia): The R-717, i.e. ammonia (NH₃) is one of the oldest and most widely used of all the refrigerants. Its greatest application is found in large and commercial reciprocating compression systems where high toxicity is secondary. It is also widely used in absorption systems.

It is a chemical compound of nitrogen and hydrogen and under ordinary conditions, it is a colourless gas. Its boiling point at atmospheric pressure is -33.3°C and its melting point from the solid is -78°C. The condenser pressure at 30°C is 10.78 bar. The condensers for R-717 are usually of water cooled type.

R-729 (Air): The dry air is used as a gaseous refrigerant in some compression systems. Particularly in air-craft air conditioning.

R-744 (Carbon dioxide): The principal refrigeration use of carbon dioxide is same as that of dry ice. It is non-toxic, non-irritating and non-flammable. The boiling point of this refrigerant is so extremely low (-73.6°C) that at -15°C, a pressure of well over 20.7 bar is required to prevent its evaporation. At a condenser temperature of +30°C, a pressure of approximately 70 bar is required to liquefy the gas.

R-764 (Sulphur dioxide): This refrigerant is produced by the combustion of sulphur in air. In the former years, it was widely used in household and small commercial units. The boiling point of sulphur dioxide is -10°C at atmospheric pressure.

HYDRO-CARBON REFRIGERANTS:-

Most of the hydro-carbon refrigerants are successfully used in industrial and commercial installations. They possess satisfactory thermodynamic properties but are highly flammable and explosive. The various hydro-carbon refrigerants are given in the following table:

Refrigerant number	Chemical name	Chemical formula
R-170	Ethane	C ₂ H ₆
R-290	Propane	C ₃ H ₈
R-600	Butane	C ₄ H ₁₀

THERMODYNAMIC PROPERTIES OF REFRIGERANTS:

1. **Boiling Temperature-** The boiling temperature of the refrigerant at atmospheric pressure should be low.
2. **Freezing temperature -:** The freezing temperature of a refrigerant should be well below the operating evaporator temperature.
3. **Evaporator and condenser pressure.** Both the evaporating (low side) and condensing (high side) pressures should be positive (above atmospheric) and it should be as near to the atmospheric pressure as possible.
4. **Critical temperature and pressure.** The critical temperature of a refrigerant is the highest temperature at which it can be condensed to a liquid, regardless of a higher pressure.
5. **Coefficient of performance and power requirements.** For an ideal refrigerant operating between -15°C evaporator temperature and 30°C condenser temperature, the theoretical coefficient of performance for the reversed Carnot cycle is 5.74.
6. **Latent heat of vaporization.** A refrigerants should have a high latent heat of vapourisation at the evaporator temperature. The high latent heat result in high refrigerating effect per kg of refrigerant circulated.
7. **Specific volume.** The specific volume of the refrigerant vapour at evaporator temperature (volume of suction vapour to the compressor) indicates the theoretical displacement of the compressor. The reciprocating compressors are used with refrigerants having high pressures and low volumes of the suction vapour.

CHEMICAL PROPERTIES OF REFRIGERANTS-:

1. **Flammability:** We have already discussed those hydro-carbon refrigerants such as ethane, propane etc., are highly flammable. Ammonia is also somewhat flammable and becomes explosive when mixed with air in the ratio of 16 to 25 percent of gas by volume. The halo-carbon refrigerants are neither flammable nor explosive.
2. **Toxicity:** The toxicity of refrigerant may be of prime or secondary importance, depending upon the application. Some non-toxic refrigerants (all fluorocarbon refrigerants) when mixed with certain percentage of air become toxic.
3. **Solubility of water:** Water is only soluble in R-12. at -18°C, it will hold six parts per million by weight. The solution formed is very slightly corrosive to any of the common metals.
4. **Miscibility:** The ability of a refrigerant to mix with oil is called miscibility.

PHYSICAL PROPERTIES OF REFRIGERANTS-:

1. **Stability and inertness:** An ideal refrigerant should not decompose at any temperature normally encountered in the refrigerating system.
2. **Corrosive property:** The corrosive property of a refrigerant must be taken into consideration while selecting the refrigerant. The Freon group of refrigerants are non-corrosive with practically all metals.
3. **Viscosity:** The refrigerant in the liquid and vapour states should have low viscosity.

SECONDARY REFRIGERANTS (BRINES)-:

Brines are secondary refrigerants and are generally used where temperature are required to be maintained below the freezing point of water (0°C).

Brine is a solution of a salt in water, it may be noted that when a salt is mixed in water, then the freezing temperature of the solution becomes lower than that of the water.

Introduction-:

The psychrometry is that branch of engineering science, which deals with the study of moist air (dry air mixed with water vapour or humidity).

Psychrometric terms-:

Through there are many psychrometric terms, yet the following are important from the subject point of view:

- 1) Dry air: The pure dry air is a mixture of a number of gases such as nitrogen, oxygen, carbon dioxide, hydrogen, argon, neon, helium etc. But the nitrogen and oxygen have the major portion of the combination.
- 2) Moist air: It is a mixture of dry air and water vapour.
- 3) Saturated air: It is a mixture of dry air and water vapour, when the air has diffused the maximum amount of water vapour into it.
- 4) Degree of saturation: It is the ratio of actual mass of water vapour in a unit mass of dry air to the mass of water vapour in the same mass and pressure of dry air when it is saturated at the same temperature.
- 5) Humidity: It is the mass of water vapour present in 1 kg of dry air, and is generally expressed in terms of gram per kg of dry air (g/kg of dry air). It is also called specific humidity or humidity ratio.
- 6) Absolute humidity: It is the mass of water vapour present in 1 m³ of dry air, and is generally expressed in terms of gram per cubic meter of dry air (g/m³ of dry air). It is also expressed in terms of grains per cubic metre of dry air.
- 7) Relative humidity: It is the ratio of actual mass of water vapour in a given volume of moist air to the mass of water vapour in the same volume of saturated air at the same temperature and pressure.

- 8) Dry bulb temperature: It is the temperature of air recorded by a thermometer, when it is not affected by the moisture present in the air. The dry bulb temperature is generally denoted by t_d or t_{db} .
- 9) Wet bulb temperature: It is the temperature of air recorded by a thermometer, when its bulb is surrounded by a wet cloth exposed to the air. Such a thermometer is called wet bulb thermometer. The wet bulb temperature is generally denoted by t_w or t_{wb} .
- 10) Dew point temperature: It is the temperature of air recorded by a thermometer, when the moisture (water vapour) present in its begins to condense.

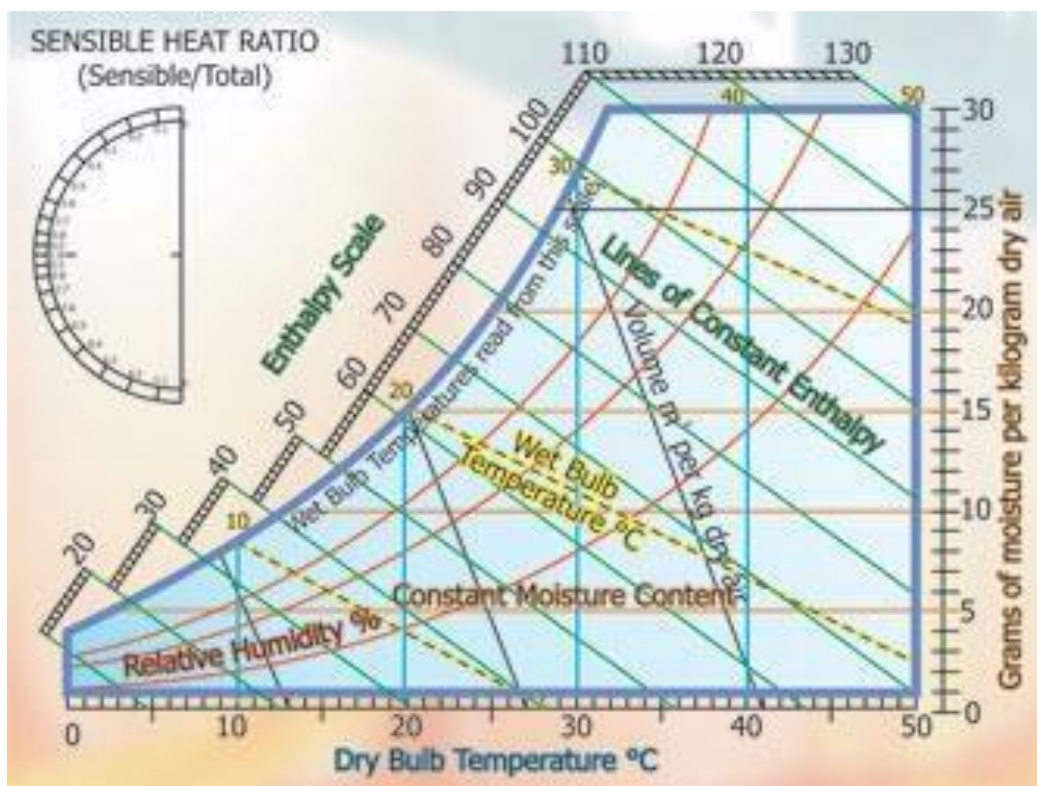

- 11) Psychrometer: There are many types of psychrometers, but the sling psychrometer as shown in fig. is widely used. It consists of a dry bulb thermometer and a wet bulb thermometer mounted side by side in a protective case that is attached to a handle by a swivel connection so that the case can be easily rotated. The dry bulb thermometer is directly exposed to air and measures the actual temperature of the air. The bulb of the wet bulb thermometer is covered by a wick thoroughly wetted by distilled water.

The sling psychrometer is rotated in the air for approximately one minute after which the reading from both the thermometer are taken.

DALTON'S LAW OF PARTIAL PRESSURES:

It states, "The total pressure exerted by the mixture of air and water vapour is equal to the sum of the pressures, which each constituent would exert, if it occupied the same space by itself". Mathematically, barometric pressure of the mixture,

$$P_b = p_a + p_v$$

Psychrometric relations

Let p_a , v_a , T_a , m_a and R_a = Pressure, volume, absolute temperature, mass and gas constant respectively for dry air, and

P_v , v_v , T_v , m_v and R_v = Corresponding values for the water vapour.

Assuming that the dry air and water vapour behave as perfect gases, we have for dry air,

$$P_a v_a = m_a R_a T_a \quad \dots (i)$$

And for water vapour,

$$P_v v_v = m_v R_v T_v \quad \dots (ii)$$

Also $v_a = v_v$

And $T_a = T_v = T_d$

...(where T_d is dry bulb temperature)

From equation (i) and (ii), we have

$$\frac{P_v}{P_a} = \frac{m_v R_v}{m_a R_a}$$

∴ Humidity ratio,

$$W = \frac{m_v}{m_a} = \frac{R_a P_v}{R_v P_a}$$

Substituting $R_a = 0.287 \text{ kJ/kg K}$ for dry air and $R_v = 0.461 \text{ kJ/kg}^\circ\text{K}$ for water vapour in the above equation, we have

$$W = \frac{0.287 \times P_v}{0.461 \times P_a} = 0.622 \times \frac{P_v}{P_a} = 0.622 \times \frac{P_v}{P_b - P_v} \quad \dots \text{ (* } p_b = p_a + p_v)$$

For saturated air (when the air is holding maximum amount of water vapour), the humidity ratio or maximum specific humidity,

$$W_s = W_{\max} = 0.622 \times \frac{P_s}{P_b - P_s}$$

Where p_s = Partial pressure of air corresponding to saturation temperature (dry bulb temperature t_d)

Degree of saturation or percentage humidity.

$$\mu = \frac{W}{W_s} = \frac{\frac{0.622 p_v}{p_b - p_v}}{\frac{0.622 p_s}{p_b - p_s}} = \frac{p_v}{p_s} \left(\frac{p_b - p_s}{p_b - p_v} \right) = \frac{p_v}{p_s} \left[\frac{1 - \frac{p_s}{p_b}}{1 - \frac{p_v}{p_b}} \right]$$

Relative humidity.

$$\phi = \frac{m_v}{m_s}$$

Let p_v, v_v, T_v, m_v and R_v = Pressure, volume, temperature, mass and gas constant respectively for water vapour in actual conditions, and

p_s, v_s, T_s, m_s and R_s = Corresponding values for water vapour in saturated air.

We know that for water vapour in actual conditions,

$$P_v v_v = m_v R_v T_v \quad \dots (i)$$

Similarly, for water vapour in saturated air,

$$P_s v_s = m_s R_s T_s \quad \dots (ii)$$

According to the definitions:

$$V_v = v_s$$

And $T_v = T_s$

Also $R_v = R_s = 0.461 \text{ kJ/kg K}$

\therefore From (i) and (ii), relative humidity,

$$\phi = \frac{m_v}{m_s} = \frac{p_v}{p_s}$$

Pressure of water vapour. According to Carrier's equation, the partial pressure of water vapour,

$$P_v = p_w - \frac{(p_b - p_w)(t_d - t_w)}{1544 - 1.44 t_w}$$

Where p_w = Saturation pressure corresponding to wet bulb temperature (from steam table)

P_b = Barometric pressure,

t_d = Dry bulb temperature, and

t_w = Wet bulb temperature.

Vapour density or absolute humidity.

Let v_v = Volume of water vapour in m^3/kg of dry air at its partial pressure,

V_a = Volume of dry air in m^3/kg of dry air at its partial pressure,

ρ_v = Density of water vapour in kg/m^3 corresponding to its partial pressure and dry bulb temperature t_d , and

ρ_a = Density of dry air in kg/m^3 of dry air,

We know that mass of water vapour,

$$m_v = v_v \rho_v$$

and mass of dry air, $m_a = v_a \rho_a$

Dividing equation (i) by equation (ii),

$$\frac{m_v}{m_a} = \frac{v_v \rho_v}{v_a \rho_a}$$

Since $v_a = v_v$, therefore humidity ratio,

$$W = \frac{m_v}{m_a} = \frac{\rho_v}{\rho_a} \quad \text{or} \quad \rho_v = W \rho_a \dots\dots\dots (iii)$$

We know that:

$$P_a v_a = m_a R_a T_d$$

Since $v_a = \frac{1}{\rho_a}$ and $m_a = 1$ kg, therefore substituting these values in the above expression.

We get

$$P_a \times \frac{1}{\rho_a} = R_a T_d \quad \text{or} \quad \rho_a = \frac{P_a}{R_a T_d}$$

Substituting the value of ρ_a in equation (iii), we have

$$\rho_v = \frac{W P_a}{R_a T_d} = \frac{W(p_b - p_v)}{R_a T_d}$$

Where p_a = Pressure of air in kN/m^2 ,
 R_a = Gas constant for air = 0.287 kJ/kg K, and
 T_d = Dry bulb temperature in K.

Q.no-

The reading from a sling psychrometer are as follows :

Dry bulb temperature = 30°C ; wet bulb temperature = 20°C ;

Barometer reading = 740 mm of Hg.

Using steam table, determine: 1. Dew point temperature ; 2. Relative humidity ; 3. Specific humidity ; 4. Degree of saturation ; 5. Vapour density ; and 6. Enthalpy of mixture per kg of dry air.

Solution:

Given that: $t_d = 30^\circ\text{C}$; $t_w = 20^\circ\text{C}$; $p_b = 740$ mm of Hg

1) Dew point temperature:

First of all, let us find the partial pressure of vapour (p_v).

From steam tables, we find that the saturation pressure corresponding to wet bulb temperature of 20°C is

$$P_w = 0.02337 \text{ bar}$$

We know that barometric pressure,

$$\begin{aligned} P_b &= 740 \text{ mm of Hg} \\ &= 740 \times 133.3 = 98642 \text{ N/m}^2 && (*1 \text{ mm of Hg} = 133.3 \text{ N/m}^2) \\ &= 0.98642 \text{ bar} && (*1 \text{ bar} = 10^5 \text{ N/m}^2) \end{aligned}$$

∴ Partial pressure of vapour

$$\begin{aligned} P_v &= p_w - \frac{(p_b - p_w)(t_d - t_w)}{1547 - 1.44 t_w} \\ &= 0.02337 - \frac{(0.98642 - 0.02337)(30 - 20)}{1547 - 1.44 \times 20} \end{aligned}$$

$$= 0.02337 - 0.00634 = 0.01703 \text{ bar}$$

Since the dew point temperature is the saturation temperature corresponding to the partial pressure of water vapour (p_v), therefore from steam tables, we find that corresponding to a pressure of 0.017 bar, the dew point temperature is

$$T_{dp} = 15^\circ\text{C} \quad \text{Ans.}$$

2) Relative humidity

From steam tables, we find that the saturation pressure of vapour corresponding to dry bulb temperature of 30°C is

$$P_s = 0.04242 \text{ bar}$$

We know that relative humidity,

$$\phi = \frac{p_v}{p_s} = \frac{0.01703}{0.04242} = 0.4015 \text{ or } 40.15\% \quad \text{Ans.}$$

3) Specific humidity

We know that specific humidity,

$$\begin{aligned} W &= \frac{0.622 p_v}{p_b - p_v} = \frac{0.622 \times 0.01703}{0.98642 - 0.01703} \\ &= \frac{0.01059}{0.96939} = 0.010924 \text{ kg/kg of dry air} \\ &= 10.924 \text{ g/kg of dry air} \quad \text{Ans.} \end{aligned}$$

4) Degree of saturation

We know that specific humidity of saturated air,

$$\begin{aligned} W_s &= \frac{0.622 p_s}{p_b - p_s} = \frac{0.622 \times 0.04242}{0.98642 - 0.04242} \\ &= \frac{0.02638}{0.944} = 0.027945 \text{ kg/kg of dry air} \end{aligned}$$

We know that degree of saturation,

$$\mu = \frac{W}{W_s} = \frac{0.010924}{0.027945} = 0.391 \text{ or } 39.1\% \quad \text{Ans.}$$

Note- The degree of saturation (μ) may also be calculated from the following relation:

$$\begin{aligned} \mu &= \frac{p_v}{p_s} \left(\frac{p_b - p_s}{p_b - p_v} \right) \\ &= \frac{0.01703}{0.04242} = \left[\frac{0.98642 - 0.04242}{0.98642 - 0.01703} \right] \\ &= 0.391 \text{ or } 39.1\% \quad \text{Ans.} \end{aligned}$$

5) Vapour density,

$$\begin{aligned} \rho_v &= \frac{w (p_b - p_v)}{R_d T_d} = \frac{0.010924 (0.98642 - 0.01703) 10^5}{287 (273 + 30)} \\ &= 0.01218 \text{ kg/m}^3 \text{ of dry air} \quad \text{Ans.} \end{aligned}$$

6) Enthalpy of mixture per kg of dry air

From steam tables, we find that the latent heat of vaporization of water at dew point temperature of 15°C is

$$h_{fgdp} = 2466.1 \text{ kJ/kg}$$

∴ Enthalpy of mixture per kg of dry air,

$$\begin{aligned} H &= 1.022 t_d + W [h_{fgdp} + 2.3 t_{dp}] \\ &= 1.022 \times 30 + 0.010924 [2466.1 + 2.3 \times 15] \\ &= 30.66 + 27.32 = 57.98 \text{ kJ/kg of dry air} \end{aligned} \quad \text{Ans.}$$

PSYCHROMETRIC PROCESSES:

The various psychrometric processes involved in air conditioning to vary psychrometric properties of air according to the requirement are as follows:

1. Sensible heating, 2. Sensible cooling, 3. Humidification and dehumidification, 4. Cooling and adiabatic humidification, 5. Cooling and humidification by water injection, 6. Heating and humidification, 7. Humidification by steam injection, 8. Adiabatic chemical dehumidification, 9. Adiabatic mixing of air streams.

1) **Sensible Heating:**

The heating of air, without any change in its specific humidity, is known as sensible heating. Let air at temperature t_{d1} passes over a heating coil of temperature t_{d3} .

2) **Sensible Cooling:**

The cooling of air, without any change in its specific humidity, is known as sensible cooling. Let air at temperature t_{d1} passes over a cooling coil of temperature t_{d3} .

By-pass Factor of Heating and Cooling Coil:

The temperature of the air coming out of the apparatus (t_{d2}) will be less than t_{d3} in case the coil is a heating coil and more than t_{d3} in case the coil is a cooling coil.

Let 1 kg of air at temperature t_{d1} is passed over the coil having its temperature (coil surface temperature) t_{d3} .

A little consideration will show that when air passes over a coil, some of it (say x kg) just by-passes unaffected while the remaining $(1-x)$ kg comes in direct contact with the coil. This by-pass process of air is measured in terms of a by-pass factor.

Therefore, by-pass factor for heating coil,

$$\text{BPF} = \frac{t_{ds} - t_{d2}}{t_{ds} - t_{d1}}$$

Similarly, by-pass factor for cooling coil.

$$\text{BPF} = \frac{t_{d2} - t_{ds}}{t_{d1} - t_{ds}}$$

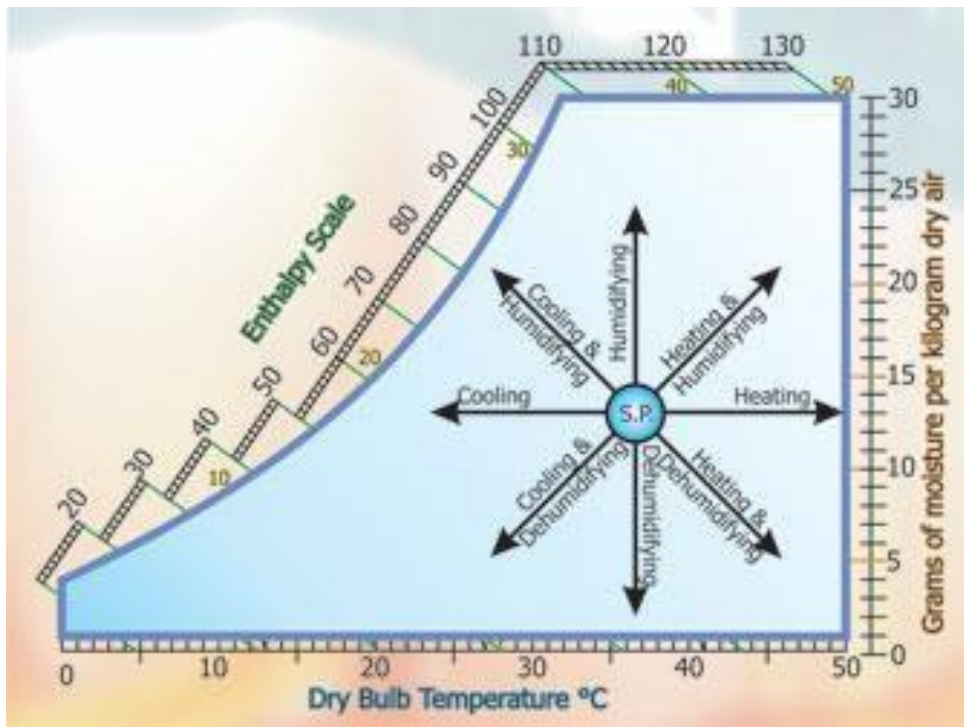

3) Humidification and Dehumidification:

The addition of moisture to the air, without change in its dry bulb temperature, is known as humidification. Similarly, removal of moisture from the air, without change in its dry bulb temperature is known as dehumidification.

Sensible Heat Factor.

The ratio of the sensible heat to the total heat is known as sensible heat factor (SHF) or sensible heat ratio (SHR). Mathematically

$$SHF = \frac{\text{Sensible heat}}{\text{Total heat}} = \frac{SH}{SH+LH}$$

Where SH = Sensible heat, and
LH = Latent heat.

4) Cooling and Dehumidification:

This process is generally used in summer air conditioning to cool and dehumidify the air. The air is passed over a cooling coil or through a cold water spray. In this process, the dry bulb temperature as well as the specific humidity of air decreases. The final relative humidity of the air is generally higher than that of the entering air.

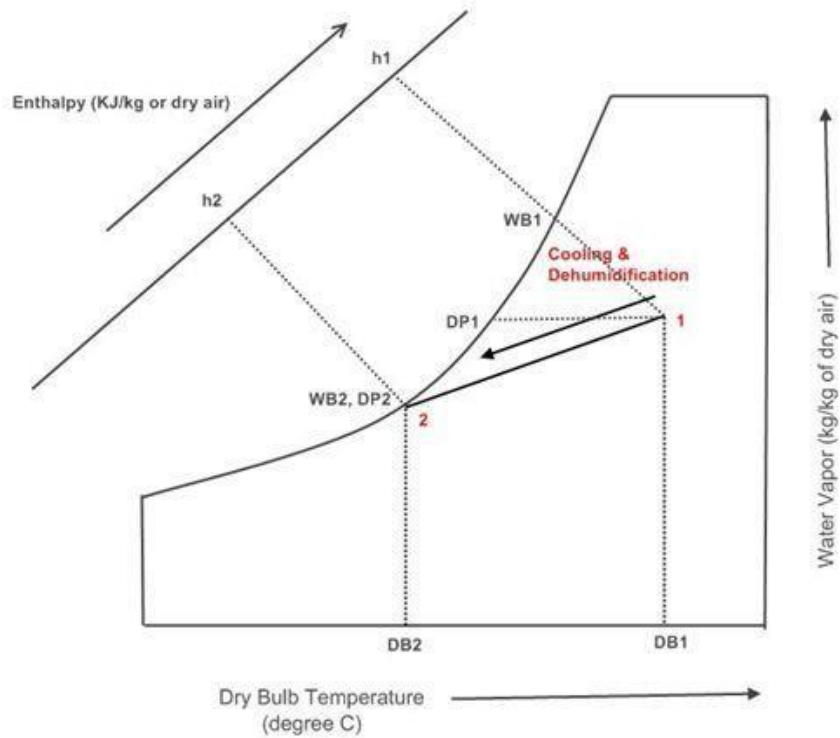

5) Cooling and Humidification by Water Injection (Evaporative Cooling)

Let water at a temperature t_1 is injected into the flowing stream of dry air as shown in figure. The final condition of air depends upon the amount of water evaporation. When the water is injected at a temperature equal to the wet bulb temperature of the entering air (t_{w1}), then the process follows the path of constant wet bulb temperature line.

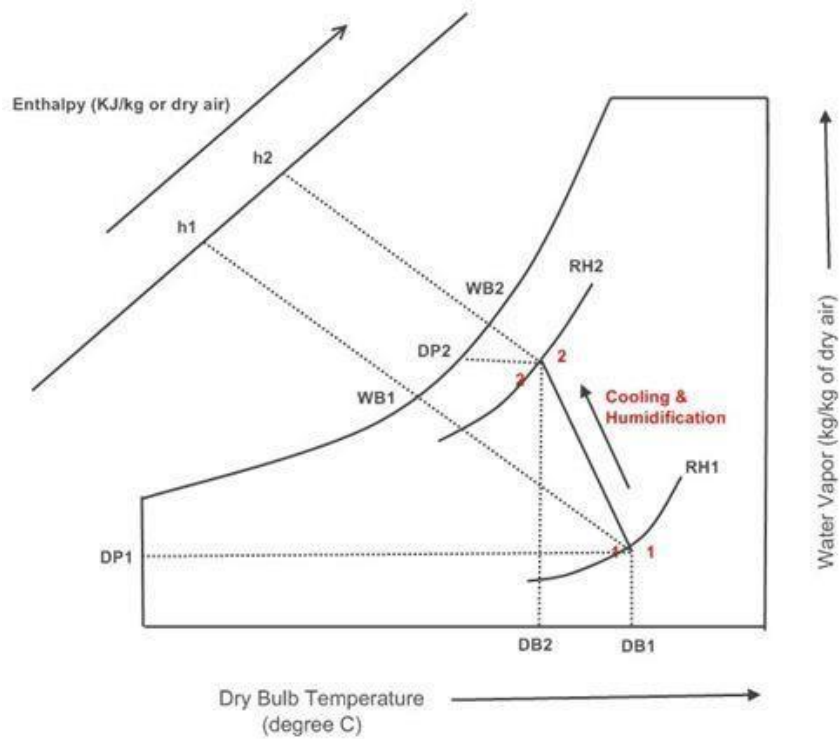

6) Heating and Humidification:

The process is generally used in winter air conditioning to warm and humidify the air. It is the reverse process of cooling and dehumidification. When air is passed through a humidifier having spray water temperature higher than the dry bulb temperature of the entering air, the unsaturated air will reach the condition of saturation and thus the air

becomes hot. The heat of vaporization of water is absorbed from the spray water itself and hence it gets cooled.

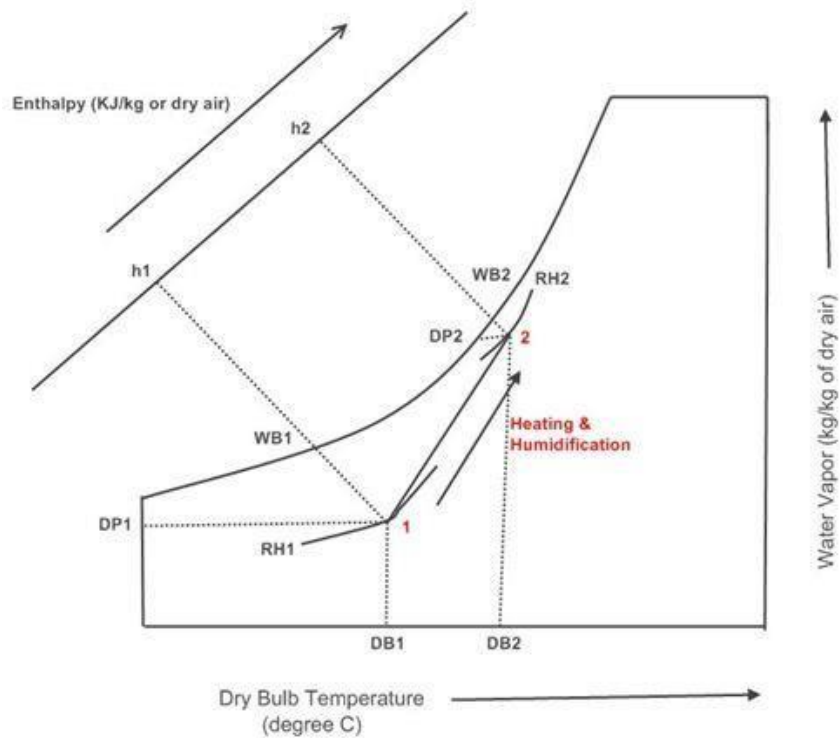

7) Adiabatic Mixing of Two Air streams:

When two quantities of air having different enthalpies and different specific humidities are mixed, the final condition of the air mixture depends upon the masses involved, and on the enthalpy and specific humidity of each of the constituent masses which enter the mixture.

Now consider two air stream 1 and 2 mixing adiabatically as shown in fig.

Let m_1 = Mass of air entering at 1,

h_1 = Enthalpy of air entering at 1,

w_1 = Specific humidity of air entering at 1,

m_2, h_2, w_2 = Corresponding values of air entering at 2, and

m_3, h_3, w_3 = Corresponding values of the mixture leaving at 3.

Assuming no loss of enthalpy and specific humidity during the air mixing process, we have for the mass balance,

$$m_1 + m_2 = m_3 \quad \dots (i)$$

for the energy balance,

$$m_1 h_1 + m_2 h_2 = m_3 h_3 \quad \dots (ii)$$

and for the mass balance of water vapour,

$$m_1 w_1 + m_2 w_2 = m_3 w_3 \quad \dots (iii)$$

substituting the value of m_3 from equation (i) in equation (ii),

$$m_1 h_1 + m_2 h_2 = (m_1 + m_2) h_3 = m_1 h_3 + m_2 h_3$$

or $m_1 h_1 - m_1 h_3 = m_2 h_3 - m_2 h_2$

$$m_1 (h_1 - h_3) = m_2 (h_3 - h_2)$$

$$\therefore \frac{m_1}{m_2} = \frac{h_3 - h_2}{h_1 - h_3} \quad \dots (iv)$$

Similarly, substituting the value of m_3 from equation (i) in equation (iii), we have

$$\frac{m_1}{m_2} = \frac{w_3 - w_2}{w_1 - w_3} \quad \dots (v)$$

Now from equation (iv) and (v),

$$\frac{m_1}{m_2} = \frac{h_3 - h_2}{h_1 - h_3} = \frac{w_3 - w_2}{w_1 - w_3} \quad \dots (vi)$$

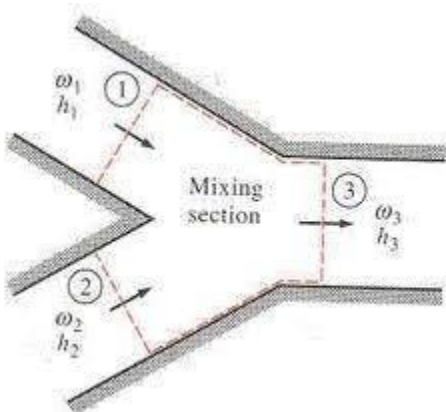

Q.no:

One kg of air at 40°C dry bulb temperature and 50% relative humidity is mixed with 2kg of air at 20°C dry bulb temperature and 20°C dew point temperature, calculate temperature and specific humidity of the mixture.

Solution:

Given: $m_1 = 1\text{kg}$; $t_{d1} = 40^\circ\text{C}$; $\phi_1 = 50\%$; $m_2 = 2\text{kg}$; $t_{d2} = 20^\circ\text{C}$ $t_{dp} = 20^\circ\text{C}$

Specific humidity of the mixture

Let $W_3 =$ Specific humidity of the mixture.

The condition of first mass of air at 40°C dry bulb temperature and 50% relative humidity is marked on the psychrometric chart at point 1, as shown in figure. Now mark the condition of second mass of air at 20°C dry bulb temperature and 20°C dew point temperature point 2, as shown in the figure. This point lies on the saturation curve. Join the points 1 and 2. From the psychrometric chart, we find that specific humidity of the first mass of air,

$$W_1 = 0.0238 \text{ kg/kg of dry air}$$

And specific humidity of the second mass of air,

$$W_2 = 0.0148 \text{ kg/kg of dry air}$$

We know that

$$\frac{m_1}{m_2} = \frac{W_3 - W_2}{W_1 - W_3}$$

$$\frac{1}{2} = \frac{W_3 - 0.0148}{0.0238 - W_3}$$

Or $0.0238 - W_3 = 2W_3 - 0.0296$

$\therefore W_3 = 0.0178 \text{ kg/kg of dry air}$ Ans.

Temperature of the mixture

Now plot point 3 on the line joining the points 1 and 2 corresponding to specific humidity $W_3 = 0.0178 \text{ kg/kg of dry air}$, as shown in figure. We find that at point 3, the dry bulb temperature of the mixture is

$T_{d3} = 26.8^\circ\text{C}$ Ans.

FACTORS AFFECTING HUMAN COMFORT:

In designing winter or summer air conditioning system, the designer should be well conversant with a number of factors which physiologically affect human comfort. The important factors are as follows:

1. Effective temperature, 2. Heat production and regulation in human body, 3. Heat and moisture losses from the human body, 4. Moisture content of air, 5. Quality and quantity of air. 6. Air motion, 7. Hot and cold surfaces, and 8. Air stratification.

1) Effective Temperature:

The degree of warmth cold felt by a human body depends mainly on the following three factors:

1. Dry bulb temperature,
2. Relative humidity, and
3. Air velocity.

In order to evaluate the combined effect of these factors, the term effective temperature is employed. It is defined as that index which correlates the combined effects of air temperature, relative humidity and air velocity on the human body. The numerical value of effective temperature is made equal to the temperature of still (5 to 8 m/min. air velocity) saturated air, which produces the same sensation of warmth or coolness as produced under the given conditions.

In the comfort chart, as shown in figure. The dry bulb temperature is taken as abscissa and the wet bulb temperature as ordinates. The relative humidity lines are replotted from the psychrometric chart. The statistically prepared graphs corresponding to summer and winter season are also superimposed. These graphs have effective temperature scale as abscissa and % of people feeling comfortable as ordinate.

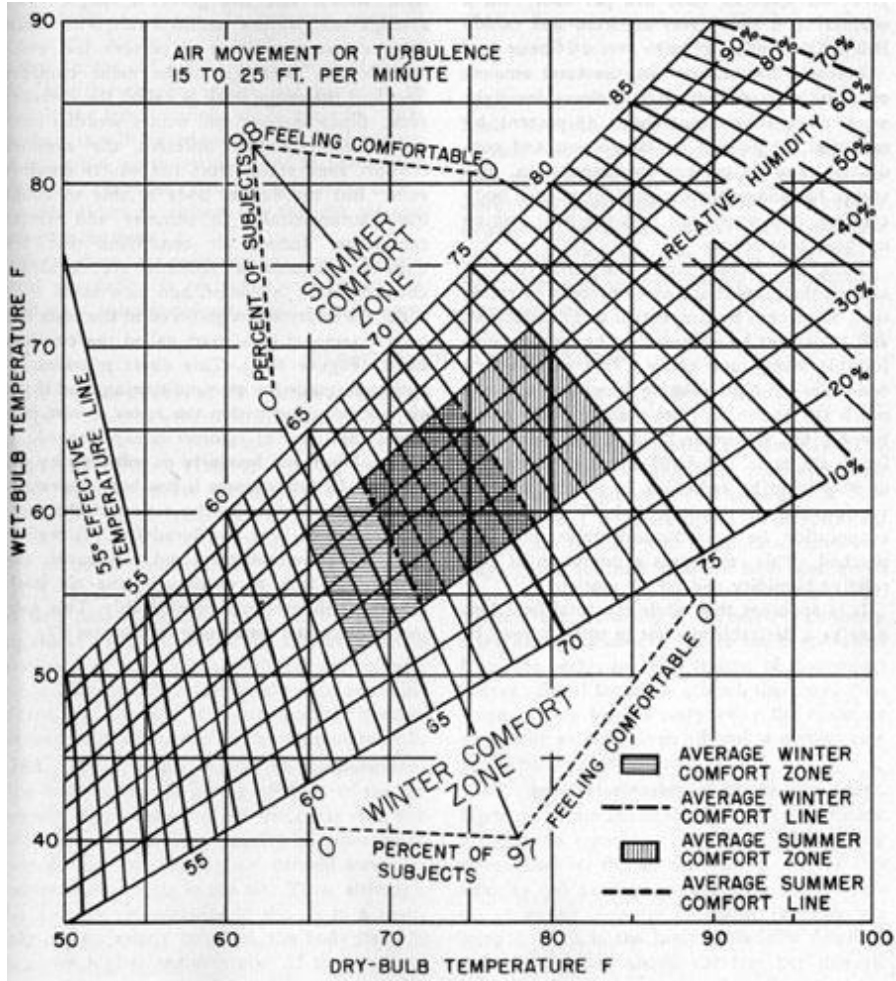

Heat production and Regulation in Human body:

The human body acts like a heat engine which gets its energy from the combustion of food within the body. The process of combustion (metabolism) produces heat and energy due to the oxidation of products in the body by oxygen obtained from inhaled air. The rate of heat production depends upon the individual's health, his physical activity and his environment. The rate at which the body produces heat is termed as metabolic rate.

FACTORS AFFECTING COMFORT AIR CONDITIONING:

The four important factors for comfort air conditioning are discussed as below:

1. **Temperature of air:** In air conditioning, the control of temperature means the maintenance of any desired temperature within an enclosed space even though the temperature of the outside air is above or below the desired room temperature.
2. **Humidity of air:** The control of humidity of air means the decreasing or increasing of moisture contents of air during summer or winter respectively in order to produce comfortable and healthy conditions.
3. **Purity of air:** It is an important factor for the comfort of a human body. It has been noticed that people do not feel comfortable when breathing contaminated air, even if it is within acceptable temperature and humidity ranges.
4. **Motion of air:** The motion or circulation of air is another important factor which should be controlled, in order to keep constant temperature though out the conditioned space.

Equipments Used in an Air conditioning system:

Following are the main equipment or parts used in an air conditioning system:

1. **Circulation fan:** The main function of this fan is to move air to and from the room.
2. **Air conditioning unit:** It is a unit, which consists of cooling and dehumidifying processes for summer air conditioning or heating and humidification processes for winter air conditioning.
3. **Supply duct:** It directs the conditioned air from the circulating fan to the space to be air conditioned at proper point.
4. **Supply outlets:** These are grills, which distribute the conditioned air evenly in the room.
5. **Return outlets:** These are the openings in a room surface which allow the room air to enter the return duct.
6. **Filters:** The main function of the filters is to remove dust, dirt and other harmful bacterias from the air.

CLASSIFICATION OF AIR CONDITIONING SYSTEMS

1. According to the purpose
 - (a) Comfort air conditioning system, and
 - (b) Industrial air conditioning system.

2. According to season of the year
 - (a) Winter air conditioning system,
 - (b) Summer air conditioning system, and
 - (c) Year-round air conditioning system.

3. According to the arrangement of equipment
 - (a) Unitary air conditioning system, and
 - (b) Central air conditioning system.

Industrial Air Conditioning System:

It is an important system of air conditioning these days in which the inside dry bulb temperature and relative humidity of the air is kept constant for proper working of the machines and for the proper research and manufacturing processes. Some of the sophisticated electronic and other machines need a particular dry bulb temperature and relative humidity. Sometimes, these machines also require a particular method of psychrometric processes. This type of air conditioning system is used in textile mills, paper mills, machine-parts manufacturing plants, tool rooms, photo-processing plant etc.

Winter Air Conditioning System

In winter air conditioning, the air is heated, which is generally accompanied by humidification. The schematic arrangement of the system is shown in figure.

The outside air flows through a damper and mixes up with the recirculated air (which is obtained from the conditioned space). The mixed air passes through a filter to remove dirt, dust and other impurities. The air now passes through a preheat coil in order to prevent the possible freezing of water and to control the evaporation of water in the humidifier. After, that the air is made to pass through a reheat coil to bring the air to the designed dry bulb temperature. Now, the conditioned air is supplied to the conditioned space by a fan. From the conditioned space, a part of the used air is exhausted to the atmosphere by the exhaust fans or ventilators. The remaining part of the used air (recirculated air) is again conditioned as shown in figure.

The outside air is sucked and made to mix with recirculated air, in order to make up for the loss of conditioned (used) air through exhaust fans or ventilation from the conditioned space.

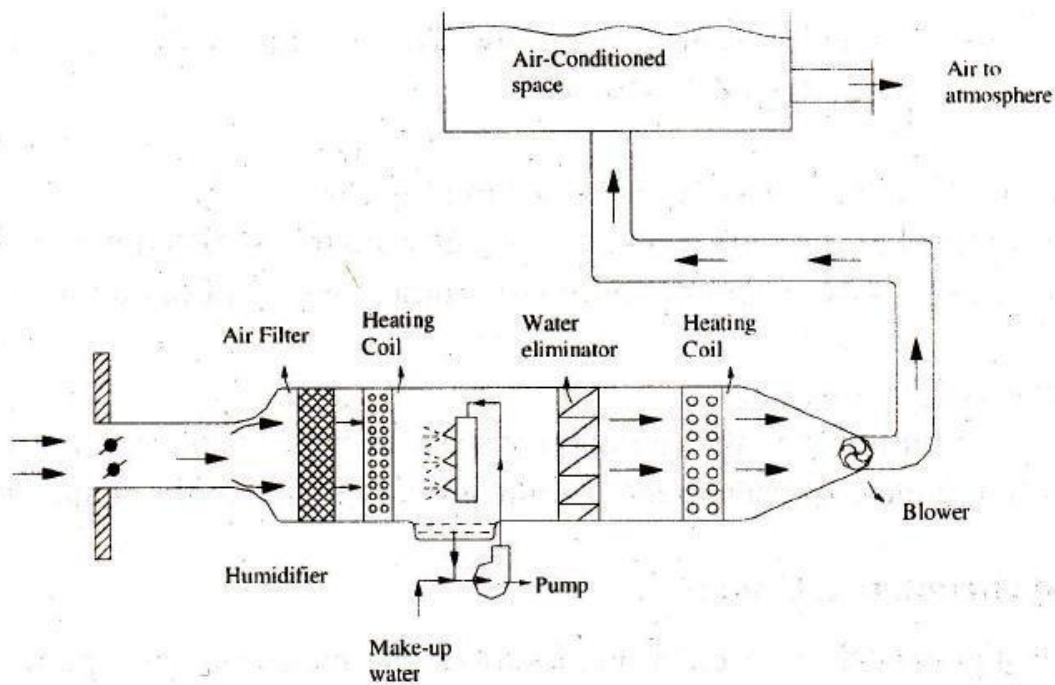

Fig. 2.29(b) Winter air-conditioning system

Summer Air Conditioning System:

It is the most important type of air conditioning, in which the air is cooled and generally dehumidified. (The schematic arrangement of a typical summer air conditioning system is shown.)

The outside air flows through the damper, and mixes up with recirculated air (which is obtained from the conditioned space). The mixed air passes through a filter to remove dirt, dust and other impurities. The air now passes through a cooling coil. The coil has a temperature much below the required dry bulb temperature of the air in the conditioned space. The cooled air passes through a perforated membrane and loses its moisture in the condensed form which is collected in a sump. After that, the air is made to pass through a heating coil which heats up the air slightly. This is done to bring the air to the designed dry bulb temperature and relative humidity.

Now the conditioned air is supplied to the conditioned space by a fan. From the conditioned space, a part of the used air is exhausted to the atmosphere by the exhaust fans or ventilators. The remaining part of the used air (recirculated air) is again conditioned as shown in fig. The outside air is sucked and made to mix with the recirculated air in order to make up for the loss of conditioned (used) air through exhaust fans or ventilation from the conditioned space.

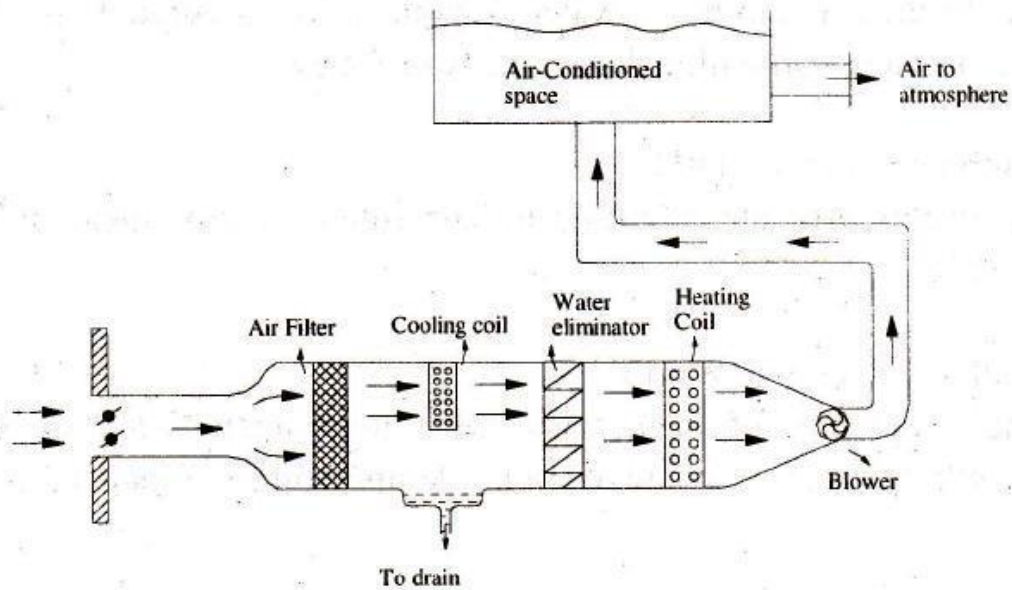

Fig. 2.29(a) Summer air-conditioning system

Year-Round Air Conditioning System

The year-round air conditioning system should have equipment for both the summer and winter air conditioning.

The outside air flows through the damper and mixes up with the recirculated air (which is obtained from the conditioned space).

The mixed air passes through a filter to remove dirt, dust and other impurities. In summer air conditioning, the cooling coil operates to cool the air to the desired value. The dehumidification is obtained by operating the cooling coil at a temperature lower than the dew point

temperature (apparatus dew point). In winter, the cooling coil is made inoperative and the heating coil operates to heat the air. The spray type humidifier is also made use in the dry season to humidify the air.

