

KIIT POLYTECHNIC

NOTES ON
POWER ELECTRONICS & PLC
5TH SEM ELECTRICAL ENGG.

Compiled by

Er. Gautam Mahto

(Lecturer in Department of Electrical Engineering, KIIT Polytechnic, BBSR)

Email- gautammahto05@gmail.com

POWER ELECTRONICS

The control of electric motor drives requires control of electric power. Power electronics have eased the concept of power control. Power electronics signifies the word power electronics and control or we can say the electronic that deal with power equipment for power control.

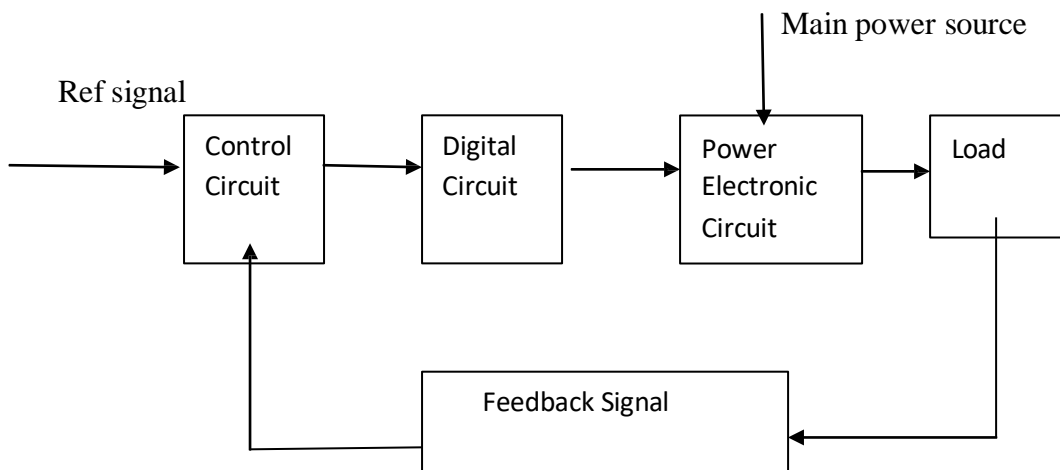

Power electronics based on the switching of power semiconductor devices. With the development of power semiconductor technology, the power handling capabilities and switching speed of power devices have been improved tremendously.

Power Semiconductor Devices

The first SCR was developed in late 1957. Power semiconductor devices are broadly categorized into 3 types:

1. Power diodes (600V,4500A)
2. Transistors
3. Thyristors (10KV,300A,30MW)

Thyristor is a four layer three junction pnpn semiconductor switching device. It has 3 terminals these are anode, cathode and gate. SCRs are solid state device, so they are compact, possess high reliability and have low loss.

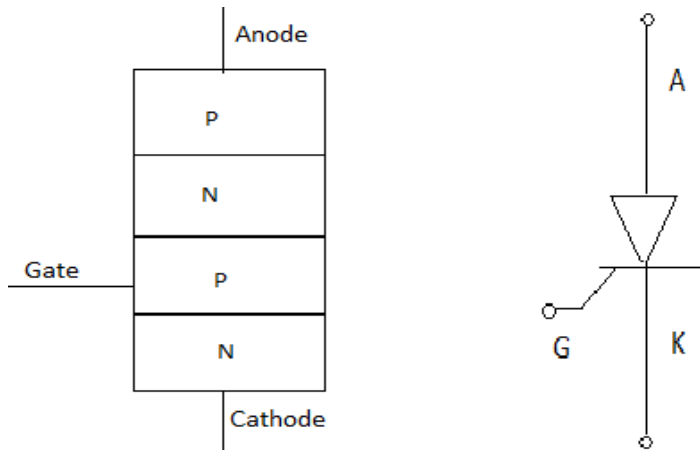

SCR is made up of silicon, it act as a rectifier; it has very low resistance in the forward direction and high resistance in the reverse direction. It is a unidirectional device.

Static V-I characteristics of a Thyristor

The circuit diagram for obtaining static V-I characteristics is as shown

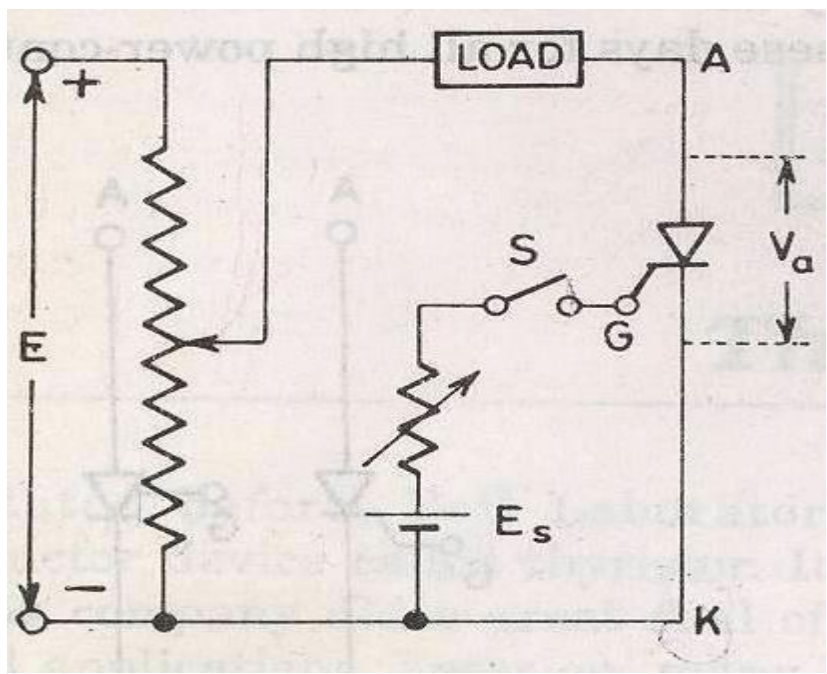

Anode and cathode are connected to main source voltage through the load. The gate and cathode are fed from source E_s .

A typical SCR V-I characteristic is as shown below:

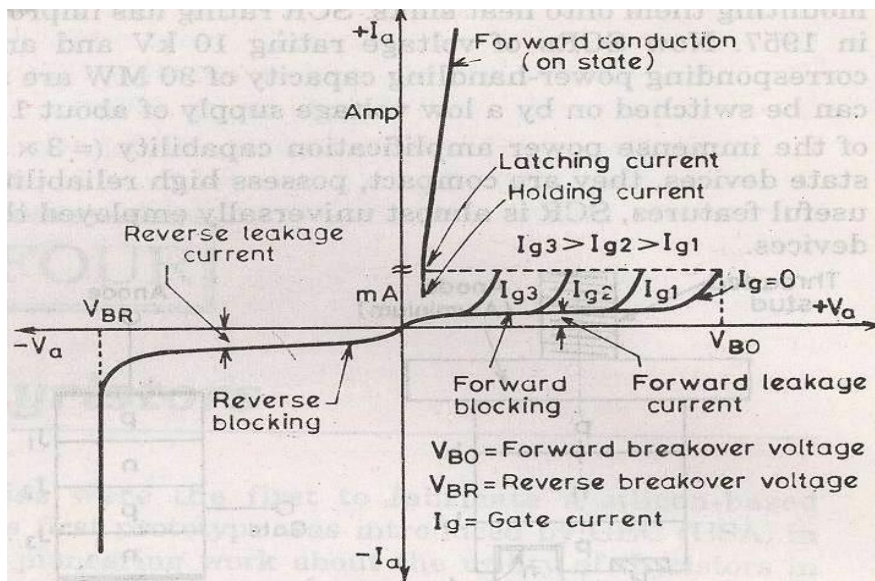

V_{BO} =Forward breakover voltage

V_{BR} =Reverse breakover voltage

I_g =Gate current

V_a =Anode voltage across the thyristor terminal A,K.

I_a =Anode current

It can be inferred from the static V-I characteristic of SCR. SCR have 3 modes of operation:

1. Reverse blocking mode
2. Forward blocking mode (off state)
3. Forward conduction mode (on state)

1. **Reverse Blocking Mode**

When cathode of the thyristor is made positive with respect to anode with switch open thyristor is reverse biased. Junctions J_1 and J_2 are reverse biased where junction J_2 is forward biased. The device behaves as if two diodes are connected in series with reverse voltage applied across them.

- A small leakage current of the order of few mA only flows. As the thyristor is reverse biased and in blocking mode. It is called as acting in reverse blocking mode of operation.
- Now if the reverse voltage is increased, at a critical breakdown level called reverse breakdown voltage V_{BR} ,an avalanche occurs at J_1 and J_3 and the reverse

current increases rapidly. As a large current associated with V_{BR} and hence more losses to the SCR.

This results in Thyristor damage as junction temperature may exceed its maximum temperature rise.

2. **Forward Blocking Mode**

When anode is positive with respect to cathode, with gate circuit open, thyristor is said to be forward biased.

Thus junction J_1 and J_3 are forward biased and J_2 is reverse biased. As the forward voltage is increases junction J_2 will have an avalanche breakdown at a voltage called forward breakover voltage V_{BO} . When forward voltage is less than V_{BO} thyristor offers high impedance. Thus a thyristor acts as an open switch in forward blocking mode.

3. **Forward Conduction Mode**

Here thyristor conducts current from anode to cathode with a very small voltage drop across it. So a thyristor can be brought from forward blocking mode to forward conducting mode:

1. By exceeding the forward breakover voltage.
2. By applying a gate pulse between gate and cathode.

During forward conduction mode of operation thyristor is in on state and behave like a close switch. Voltage drop is of the order of 1 to 2mV. This small voltage drop is due to ohmic drop across the four layers of the device.

Different turn ON methods for SCR

1. Forward voltage triggering
2. Gate triggering
3. $\frac{dv}{dt}$ triggering
4. Light triggering
5. Temperature triggering

1. **Forward voltage triggering**

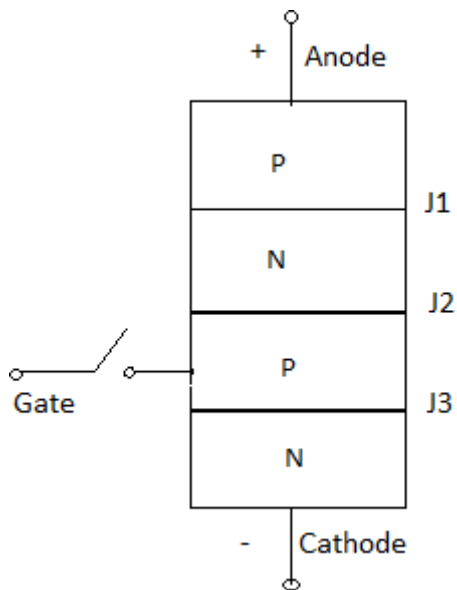

A forward voltage is applied between anode and cathode with gate circuit open.

- Junction J_1 and J_3 is forward biased.
- Junction J_2 is reverse biased.
- As the anode to cathode voltage is increased breakdown of the reverse biased junction J_2 occurs. This is known as avalanche breakdown and the voltage at which this phenomena occurs is called forward breakover voltage.
- The conduction of current continues even if the anode cathode voltage reduces below V_{BO} till I_a will not go below I_h . Where I_h is the holding current for the thyristor.

2. Gate triggering

This is the simplest, reliable and efficient method of firing the forward biased SCRs. First SCR is forward biased. Then a positive gate voltage is applied between gate and cathode. In practice the transition from OFF state to ON state by exceeding V_{BO} is never employed as it may destroy the device. The magnitude of V_{BO} , so forward breakover voltage is taken as final voltage rating of the device during the design of SCR application.

First step is to choose a thyristor with forward breakover voltage (say 800V) higher than the normal working voltage. The benefit is that the thyristor will be in blocking state with normal working voltage applied across the anode and cathode with gate open. When we require the turning ON of a SCR a positive gate voltage between gate and cathode is applied. The point to be noted that cathode n-layer is heavily doped as compared to gate p-layer. So when gate supply is given between gate and cathode gate p-layer is flooded with electron from cathode n-layer. Now the thyristor is forward biased, so some of these electron reach junction J_2 . As a result width of J_2 breaks down or conduction at J_2 occur at a voltage less than V_{BO} . As I_g increases V_{BO} reduces which decreases then turn ON time. Another important point is duration for which the gate current is applied should be more then turn ON time. This means

that if the gate current is reduced to zero before the anode current reaches a minimum value known as holding current, SCR can't turn ON.

In this process power loss is less and also low applied voltage is required for triggering.

3. dv/dt triggering

This is a turning ON method but it may lead to destruction of SCR and so it must be avoided.

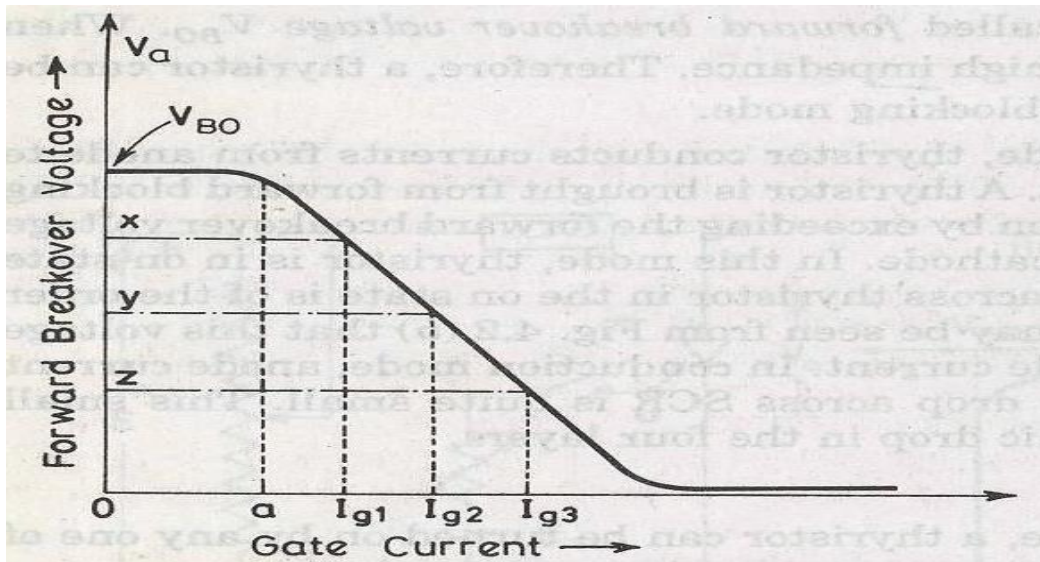

When SCR is forward biased, junction J_1 and J_3 are forward biased and junction J_2 is reverse biased so it behaves as if an insulator is placed between two conducting plates. Here J_1 and J_3 act as a conducting plate and J_2 acts as an insulator. J_2 is known as junction capacitor. So if we increase the rate of change of forward voltage instead of increasing the magnitude of voltage, junction J_2 breaks and starts conducting. A high value of changing current may damage the SCR. So SCR may be protected from high $\frac{dv}{dt}$

$$q = cv$$

$$I = c \frac{dv}{dt}$$

$$I_a \propto \frac{dv}{dt}$$

4. Temperature triggering

During forward bias, J_2 is reverse biased so a leakage forward current is always associated with SCR. Now as we know the leakage current is temperature dependent, so if we increase the temperature the leakage current will also increase and heat dissipation of junction J_2 occurs. When this heat reaches a sufficient value J_2 will break and conduction starts.

Disadvantages

This type of triggering causes local hot spot and may cause thermal run away of the device.

This triggering cannot be controlled easily.

It is very costly as protection is costly.

5. Light triggering

First a new recess niche is made in the inner p-layer. When this recess is irradiated, then free charge carriers (electron and hole) are generated. Now if the intensity is increased above a certain value then it leads to turn ON of SCR. Such SCR are known as Light activated SCR (LASCR).

Some definitions:

Latching current

The latching current may be defined as the minimum value of anode current which at must attain during turn ON process to maintain conduction even if gate signal is removed.

Holding current

It is the minimum value of anode current below which if it falls, the SCR will turn OFF.

Switching characteristics of thyristors

The time variation of voltage across the thyristor and current through it during turn on and turn off process gives the dynamic or switching characteristic of SCR.

Switching characteristic during turn on

Turn on time

It is the time during which it changes from forward blocking state to ON state. Total turn on time is divided into 3 intervals:

1. Delay time
2. Rise time
3. Spread time

Delay time

If I_g and I_a represent the final value of gate current and anode current. Then the delay time can be explained as time during which the gate current attains $0.9 I_g$ to the instant anode current reaches $0.1 I_g$ or the anode current rises from forward leakage current to $0.1 I_a$.

1. Gate current $0.9 I_g$ to $0.1 I_a$.
2. Anode voltage falls from V_a to $0.9V_a$.
3. Anode current rises from forward leakage current to $0.1 I_a$.

Rise time (t_r)

Time during which

1. Anode current rises from $0.1 I_a$ to $0.9 I_a$
2. Forward blocking voltage falls from $0.9V_a$ to $0.1V_a$. V_a is the initial forward blocking voltage.

Spread time (t_p)

1. Time taken by the anode current to rise from $0.9I_a$ to I_a .
2. Time for the forward voltage to fall from $0.1V_o$ to on state voltage drop of 1 to 1.5V. During turn on, SCR is considered to be a charge controlled device. A certain amount of charge is injected in the gate region to begin conduction. So higher the magnitude of gate current it requires less time to inject the charges. Thus turn on time is reduced by using large magnitude of gate current.

How the distribution of charge occurs?

As the gate current begins to flow from gate to cathode with the application of gate signal. Gate current has a non uniform distribution of current density over the cathode surface. Distribution of current density is much higher near the gate. The density decrease as the distance from the gate increases. So anode current flows in a narrow region near gate where gate current densities are highest. From the beginning of rise time the anode current starts spreading itself. The anode current spread at a rate of 0.1mm/sec. The spreading anode current requires some time if the rise time is not sufficient then the anode current cannot spread over the entire region of cathode. Now a large anode current is applied and also a large anode current flowing through the SCR. As a result turn on losses is high. As these losses occur over a small conducting region so local hot spots may form and it may damage the device.

Switching Characteristics During Turn Off

Thyristor turn off means it changed from ON to OFF state. Once thyristor is ON there is no role of gate. As we know thyristor can be made turn OFF by reducing the anode current below the latching current. Here we assume the latching current to be zero ampere. If a forward voltage is applied across the SCR at the moment it reaches zero then SCR will not be able to block this forward voltage. Because the charges trapped in the 4-layer are still favourable for conduction and it may turn on the device. So to avoid such a case, SCR is reverse biased for some time even if the anode current has reached to zero.

So now the turn off time can be different as the instant anode current becomes zero to the instant when SCR regains its forward blocking capability.

$$t_q = t_{rr} + t_{qr}$$

Where,

t_q is the turn off time, t_{rr} is the reverse recovery time, t_{gr} is the gate recovery time

At t_1 anode current is zero. Now anode current builds up in reverse direction with same $\frac{dv}{dt}$ slope. This is due to the presence of charge carriers in the four layers. The reverse recovery current removes the excess carriers from J_1 and J_3 between the instants t_1 and t_3 . At instant t_3 the end junction J_1 and J_3 is recovered. But J_2 still has trapped charges which decay due to recombination only so the reverse voltage has to be maintained for some more time. The time taken for the recombination of charges between t_3 and t_4 is called gate recovery time t_{gr} . Junction J_2 recovered and now a forward voltage can be applied across SCR.

The turn off time is affected by:

1. Junction temperature
2. Magnitude of forward current $\frac{di}{dt}$ during commutation.

Turn off time decreases with the increase of magnitude of reverse applied voltage.

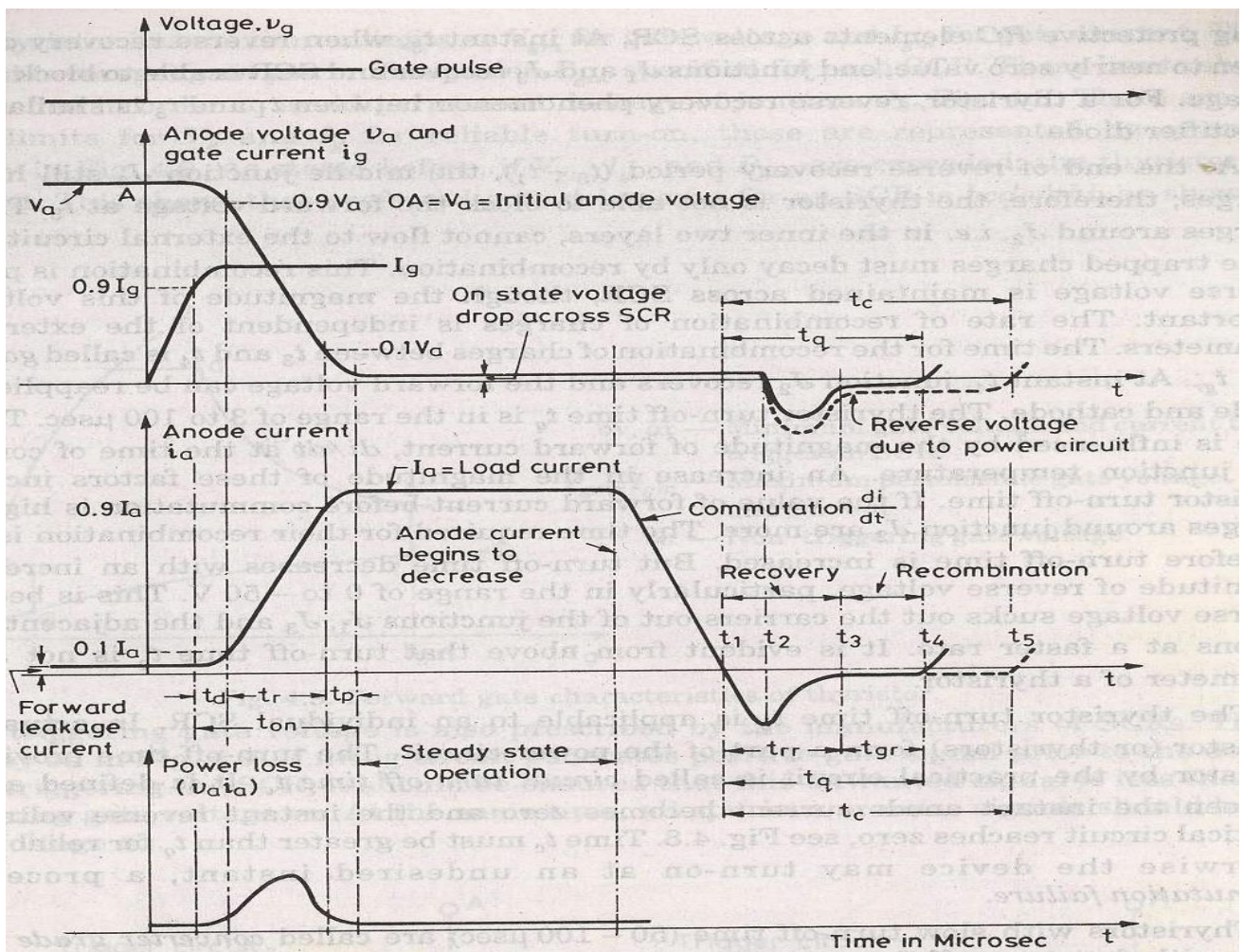

GTO(Gate turn off thyristor)

A gate turn off thyristor is a pnpn device. In which it can be turned ON like an ordinary SCR by a positive gate current. However it can be easily turned off by a negative gate pulse of appropriate magnitude.

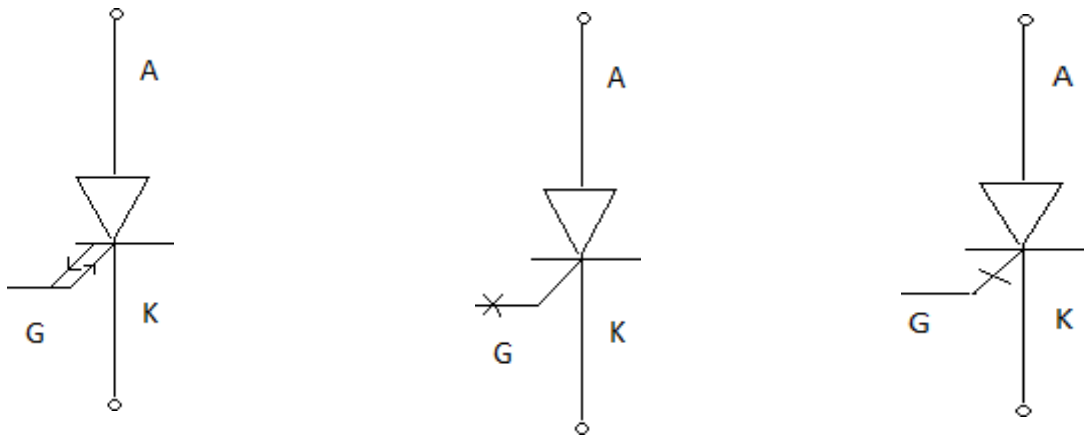

Conventional SCR are turned on by a positive gate signal but once the SCR is turned on gate loses control over it. So to turn it off we require external commutation circuit. These commutation circuits are bulky and costly. So due to these drawbacks GTO comes into existence.

The salient features of GTO are:

1. GTO turned on like conventional SCR and is turned off by a negative gate signal of sufficient magnitude.
2. It is a non latching device.
3. GTO reduces acoustic and electromagnetic noise.

It has high switching frequency and efficiency.

A gate turn off thyristor can turn on like an ordinary thyristor but it is turn off by negative gate pulse of appropriate magnitude.

Disadvantage

The negative gate current required to turn off a GTO is quite large that is 20% to 30 % of anode current

Advantage

It is compact and cost less

Switching performance

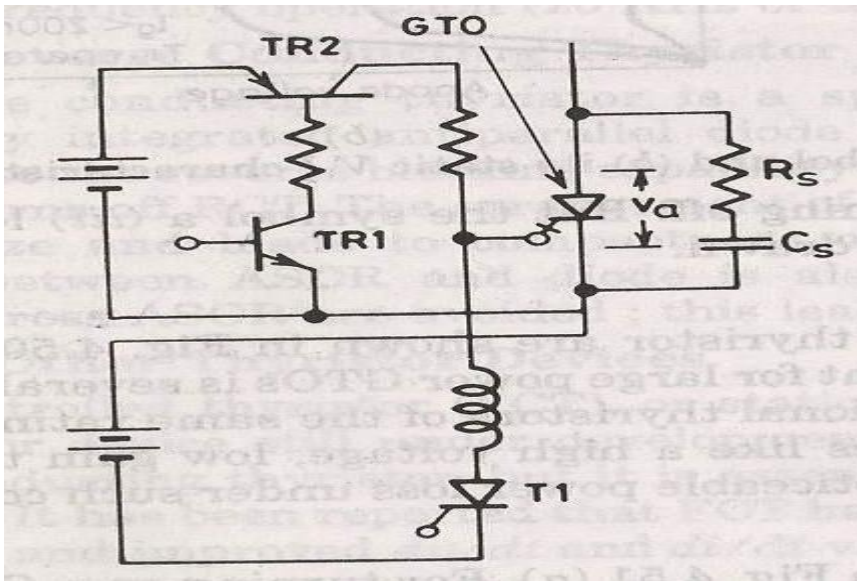

1. For turning ON a GTO first TR1 is turned on.
2. This in turn switches on TR2 so that a positive gate current pulse is applied to turn on the GTO.
3. Thyristor T_1 is used to apply a high peak negative gate current pulse.

Gate turn-on characteristics

1. The gate turn on characteristics is similar to a thyristor. Total turn on time consists of delay time, rise time, spread time.
2. The turn on time can be reduced by increasing its forward gate current.

GATE TURN OFF

Turn off time is different for SCR. Turn off characteristics is divided into 3 pd

1. Storage time
2. Fall time
3. Tail time

$$T_q = t_s + t_f + t_t$$

At normal operating condition gto carries a steady state current. The turn off process starts as soon as negative current is applied after $t=0$.

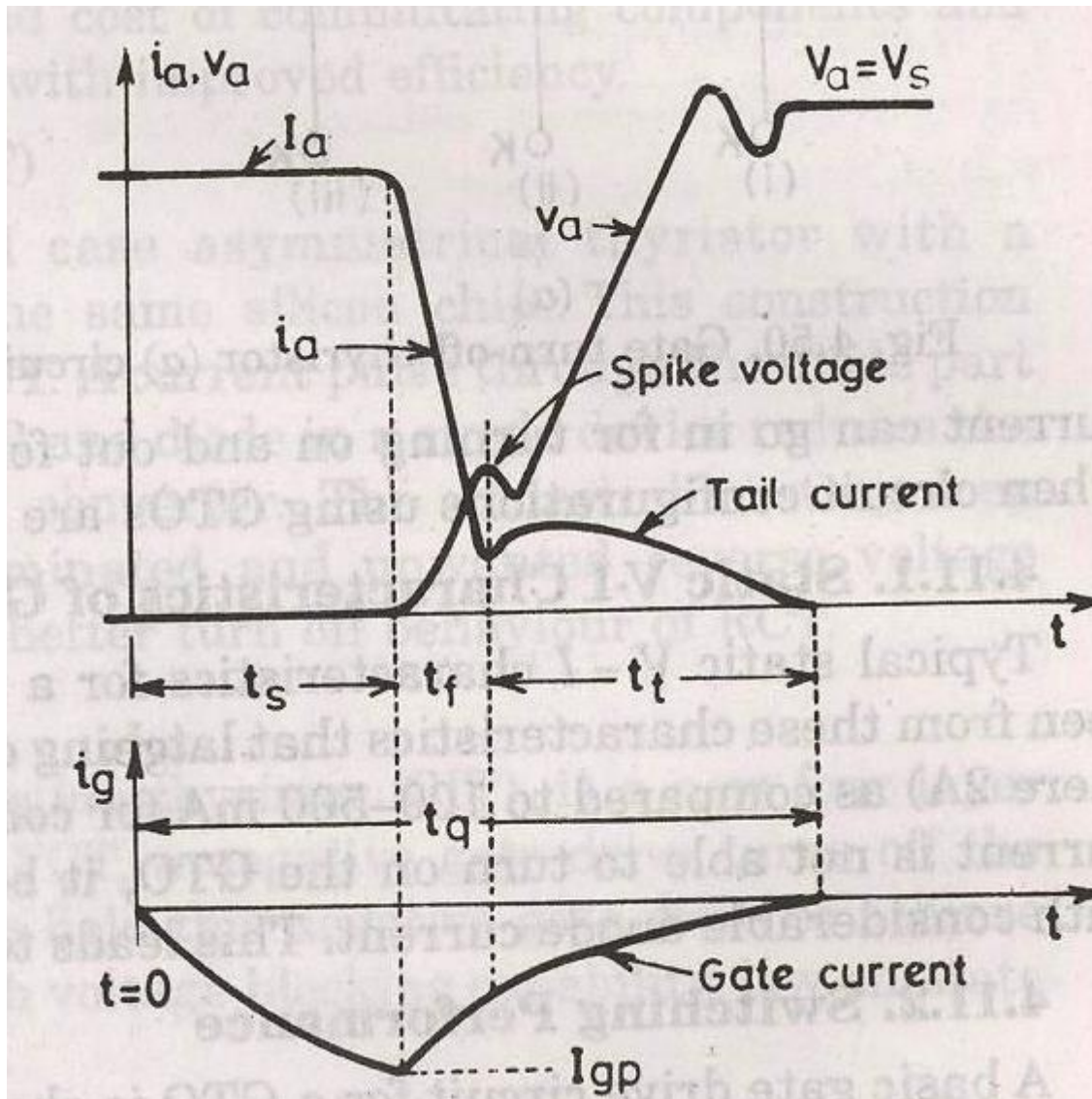

STORAGE TIME

During the storage pd the anode voltage and current remains constant. The gate current rises depending upon the gate circuit impedance and gate applied voltage. The beginning of pd is as soon as negative gate current is applied. The end of storage pd is marked by fall in anode current and rise in voltage, what we have to do is remove the excess carriers. The excess carriers are removed by negative carriers.

FALL TIME

After t_s , anode current begins to fall rapidly and anode voltage starts rising. After falling to a certain value, then anode current changes its rate to fall. This time is called fall time.

SPIKE IN VOLTAGE

During the time of storage and fall time there is a change in voltage due to abrupt current change.

TAIL TIME

During this time, the anode current and voltage continues towards the turn off values. The transient overshoot is due to the snubber parameter and voltage stabilizes to steady state value.

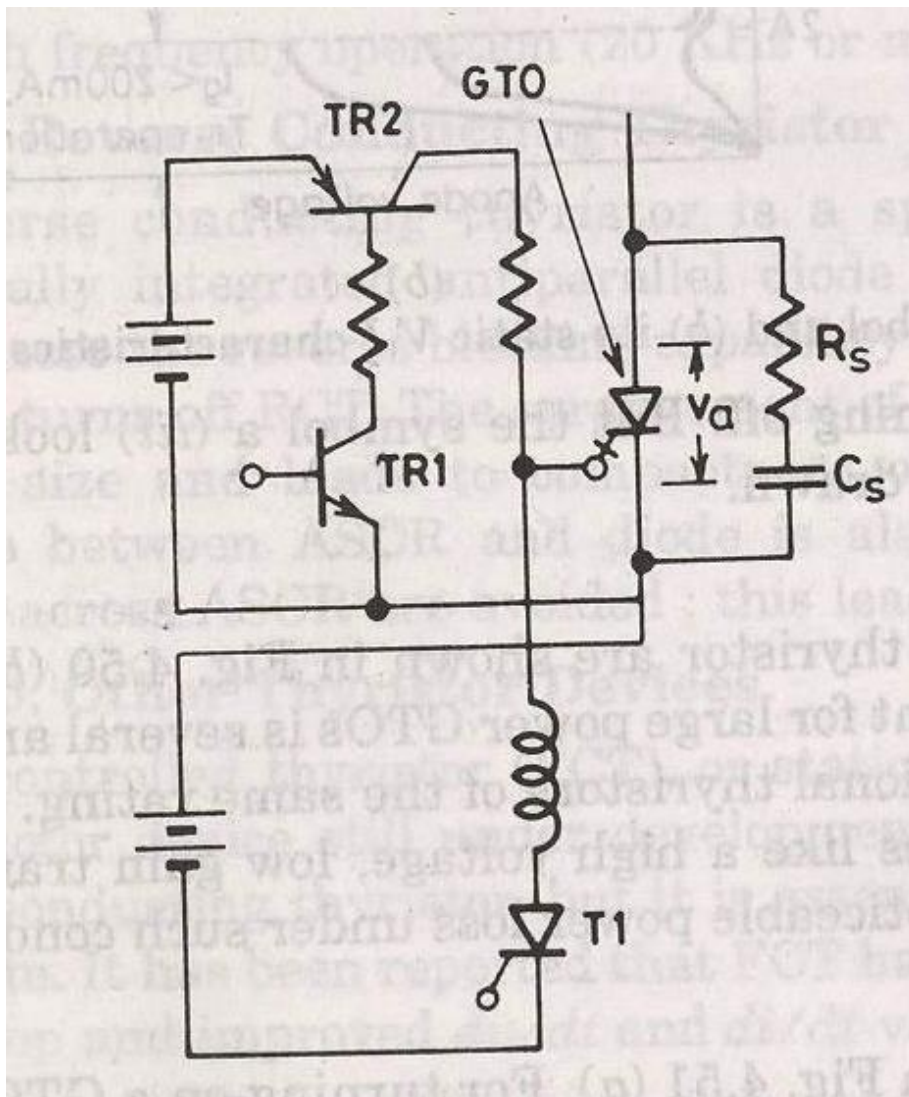

THE TRIAC

As SCR is a unidirectional device, the conduction is from anode to cathode and not from cathode to anode. It conducts in both directions. It is a bidirectional SCR with three terminals.

TRIAC=TRIODE+AC

Here it is considered to be two SCRs connected in anti-parallel. As it conducts in both directions, so it is named as MT1, MT2 and gate G.

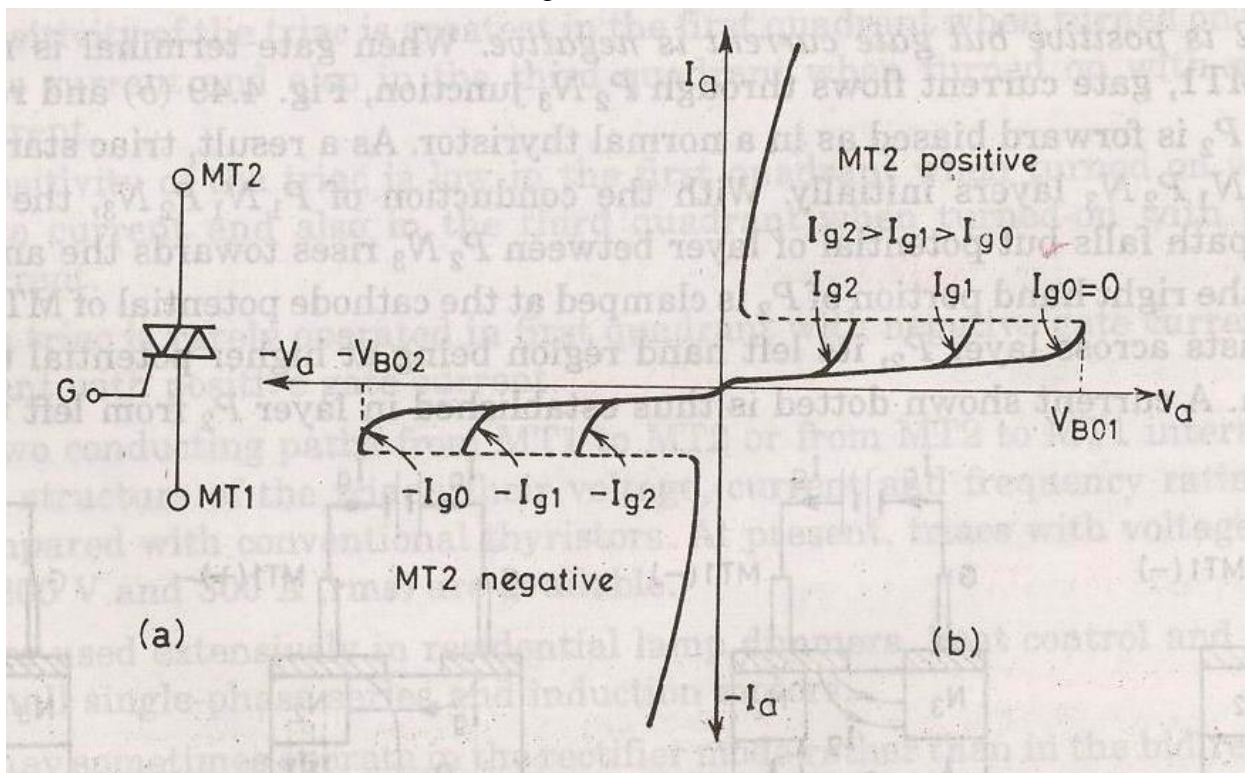

SALIENT FEATURES

1. Bi directional triode thyristor
2. TRIAC means triode that works on ac
3. It conduct in both direction
4. It is a controlled device

5. Its operation is similar to two devices connected in anti parallel with common gate connection.

6. It has 3 terminals MT1,MT2 and gate G

Its use is control of power in ac.

POWER BJT

Power BJT means a large voltage blocking in the OFF state and high current carrying capability in the ON state. In most power application, base is the input terminal. Emitter is the common terminal. Collector is the output terminal.

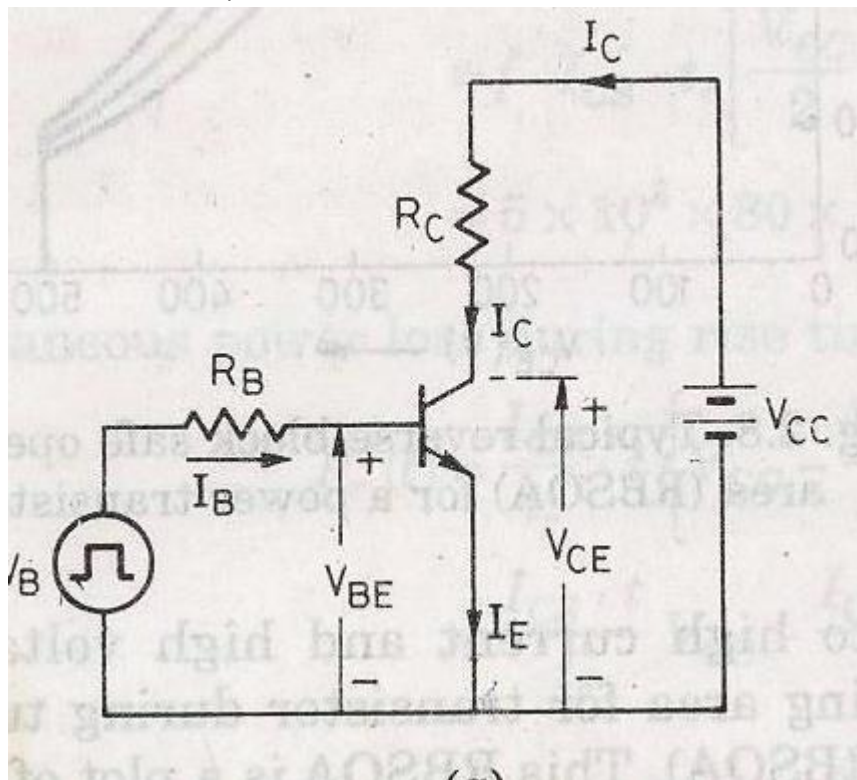

SIGNAL LEVEL OF BJT

n+ doped emitter layer ,doping of base is more than collector.Depletion layer exists more towards the collector than emitter

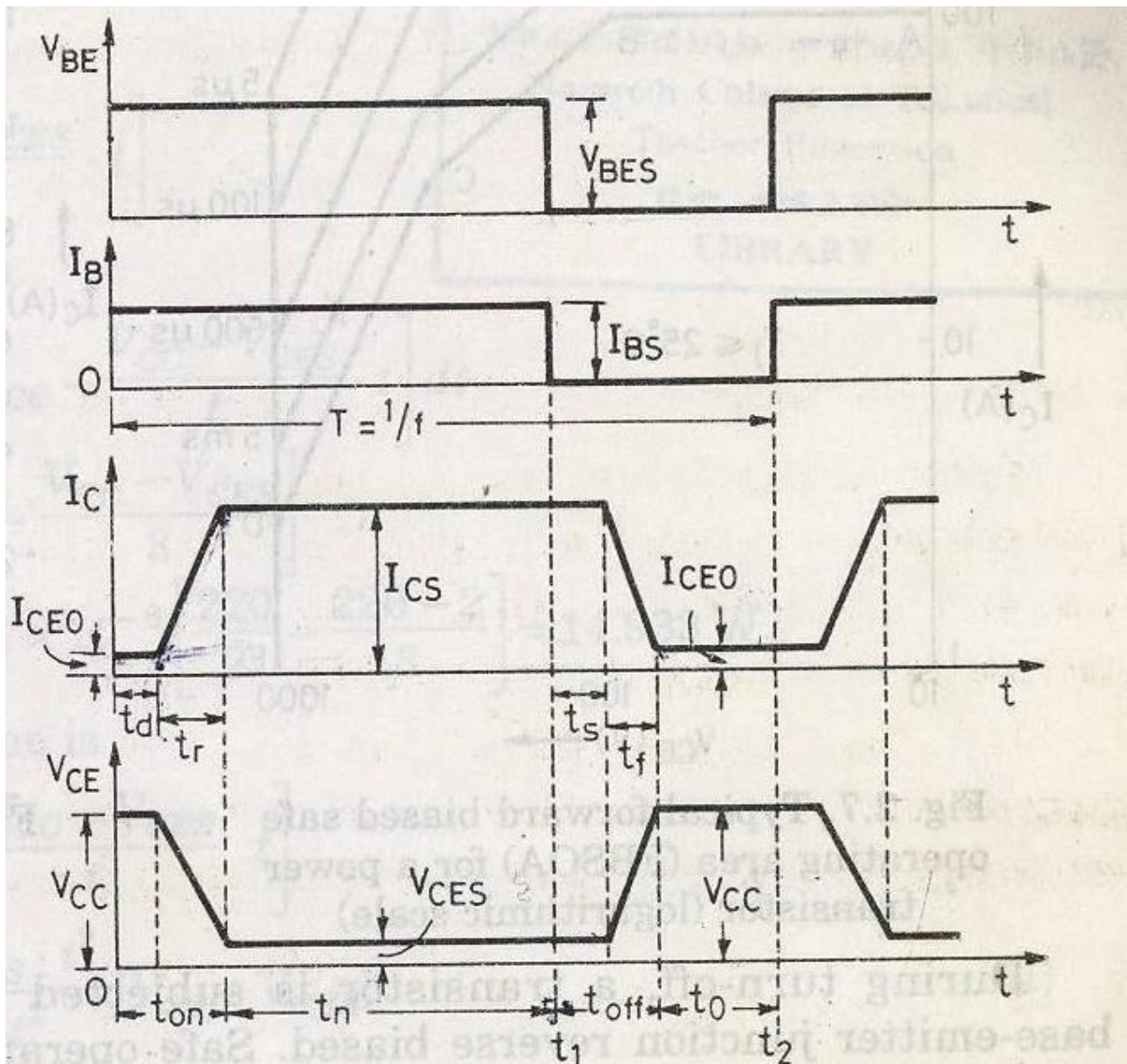

POWER BJT CONSTRUCTION

The maximum collector emitter voltage that can be sustained across the junction, when it is carrying substantial collector current.

V_{ce0} = maximum collector and emitter voltage that can be sustained by the device.

V_{cbo} = collector base breakdown voltage with emitter open

PRIMARY BREAKDOWN

It is due to conventional avalanche breakdown of the C-B junction and its associated large flow of current. The thickness of the depletion region determines the breakdown voltage of the transistor. The base thickness is made as small as possible, in order to have good amplification capability. If the thickness is too small, the breakdown voltage is compromised. So a compromise has to be made between the two.

THE DOPING LEVELS-

1. The doping of the emitter layer is quite large.
2. The base doping is moderate.
3. n- region is lightly doped.
4. n+ region doping level is similar to emitter.

1. THICKNESS OF DRIFT REGION-

It determines the breakdown length of the transistor.

2. THE BASE THICKNES –

Small base thickness- good amplification capability

Too small base thickness- the breakdown voltage of the transistor has to be compromised.

For a relatively thick base, the current gain will be relatively small, so it is increased the gain. Monolithic designs for darlington connected BJT pair have been developed.

SECONDARY BREAKDOWN

Secondary breakdown is due to large power dissipation at localized site within the semiconductor.

PHYSICS OF BJT OPERATION-

The transistor is assumed to operate in active region. There is no doped collector drift region. It has importance only in switching operation, in active region of operation.

junction is forward biased and C-B junction is reverse biased. Electrons are injected into base from the emitter. Holes are injected from base into the emitter.

QUASI SATURATION-

Initially we assume that, the transistor is in active region. Base current is allowed to increase then let's see what happens. First collector current rises in response to base current. So there is an increase in voltage drop across the collector load. So C-E voltage drops.

Because of increase in collector current, there is an increase in voltage in drift region. This eventually reduces the reverse bias across the C-B junction, so n-p junction gets smaller, at some point the junction becomes forward biased. So now injection of holes from base into collector drift region occurs. Charge neutrality requires the electron to be injected in the drift region of the holes. From where these electrons came. Since a large number of electrons is supplied to the C-B junction via injection from emitter and subsequent diffusion across the base. As excess carrier build up in the drift region begins to occur quasi saturation region is entered. As the injected carriers increase in the drift region is

gradually shorted out and the voltage across the drift region drops. In quasi saturation the drift region is not completely shorted out by high level injection. Hard saturation obtained when excess carrier density reaches the n+ side.

During quasi saturation, the rate of the collector fall. Hard saturation occurs when excess carriers have completely swept across the drift region .

THYRISTOR PROTECTION

OVER VOLTAGE PROTECTION

Over voltage occurring during the switching operation causes the failure of SCR.

INTERNAL OVERVOLTAGE

It is due to the operating condition of SCR.

During the commutation of SCR, when the anode current decays to zero anode current reverses due to stored charges. First the reverse current rises to peak value, then reverse current reduces abruptly with large di/dt . During series inductance of SCR large transient large voltage i.e $L di/dt$ is generated.

EXTERNAL OVER VOLTAGE

This is due to external supply and load condition. This is because of

1. The interruption of current flow in an inductive circuit.
2. Lightning strokes on the lines feeding the thyristor systems.

Suppose a SCR converter is fed from a transformer, voltage transient occur when transformer primary will energise or de-energised.

This overvoltages cause random turn ON of a SCR.

The effect of overvoltage is minimized using

1. RC circuits
2. Non linear resistor called voltage clamping device.

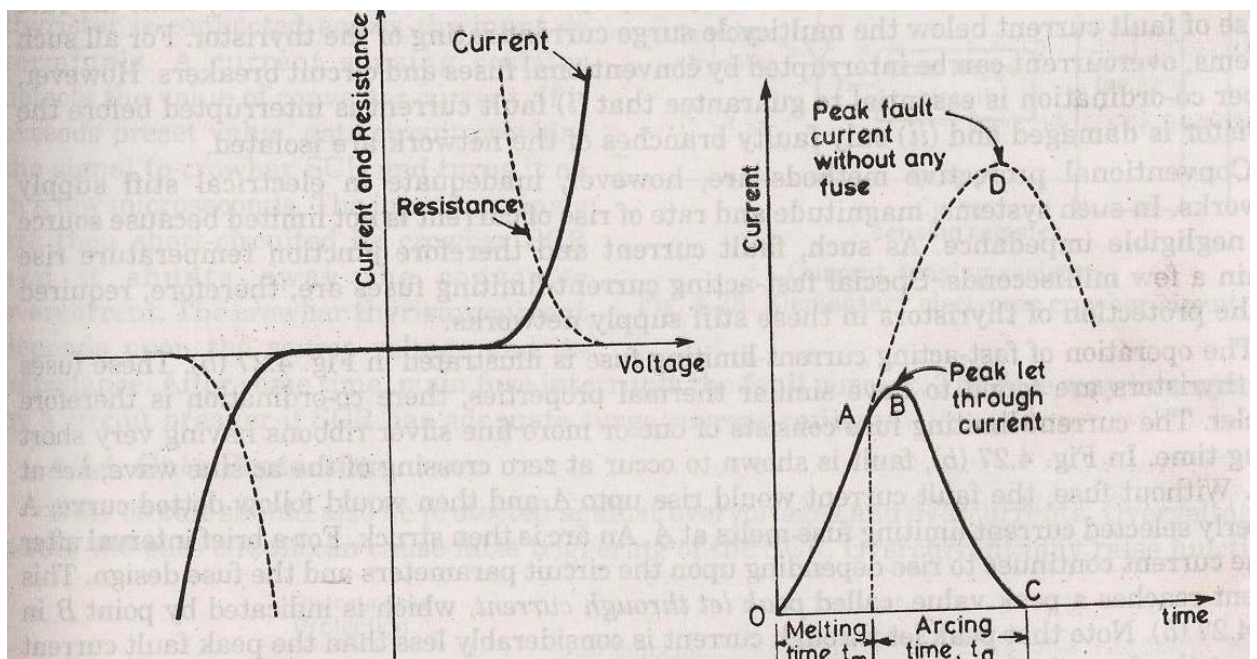

Voltage clamping device is a non linear resistor. It is connected between cathode and anode of SCR. The resistance of voltage clamping device decreases with increasing voltages. During normal working condition Voltage clamping (V.C) device has high resistance, drawing only leakage current. When voltage surge appears voltage clamping device offers a low resistance and it create a virtual short circuit across the SCR. Hence voltage across SCR is clamped to a safe value.

When surge condition over voltage clamping device returns to high resistance state.

e.g. of voltage clamping device

1. Selenium thyrector diodes
2. Metal Oxide varistors
3. Avalanche diode suppressors

OVER CURRENT PROTECTION

Long duration operation of SCR, during over current causes the

1. junction temp. of SCR to rise above the rated value, causing permanent damage to device.

SCR is protected from overcurrent by using

1. Circuit breakers
2. Fast acting fuses

Proper co-ordination is essential because

1. fault current has to be interrupted before SCR gets damaged.
2. only faulty branches of the network has to be replaced.

In stiff supply network, source has negligible impedance. So in such system the magnitude and rate of rise of current is not limited. Fault current hence junction temp rises in a few milliseconds.

POINTS TO BE NOTED-

1. Proper coordination between fast acting fuse and thyristor is essential.
2. The fuse is always rated to carry marginal overload current over definite period.
3. The peak let through current through SCR must be less than sub cycle rating of the SCR.
4. The voltage across the fuse during arcing time is called arcing or recovery voltage and is equal to sum of the source voltage and emf induced in the circuit inductance during arcing time.
5. On abrupt interruption of fuse current, induce emf would be high, which results in high arcing voltage.

Circuit Breaker (C.B)

C.B. has long tripping time. So it is used for protecting the device against continuous overload current or against the surge current for long duration. In order that fuse protects the thyristor reliably the I^2t rating of fuse current must be less than that of SCR.

ELECTRONIC CROWBAR PROTECTION

For overcurrent protection of power converter using SCR, electronic crowbar are used. It provide rapid isolation of power converter before any damage occurs.

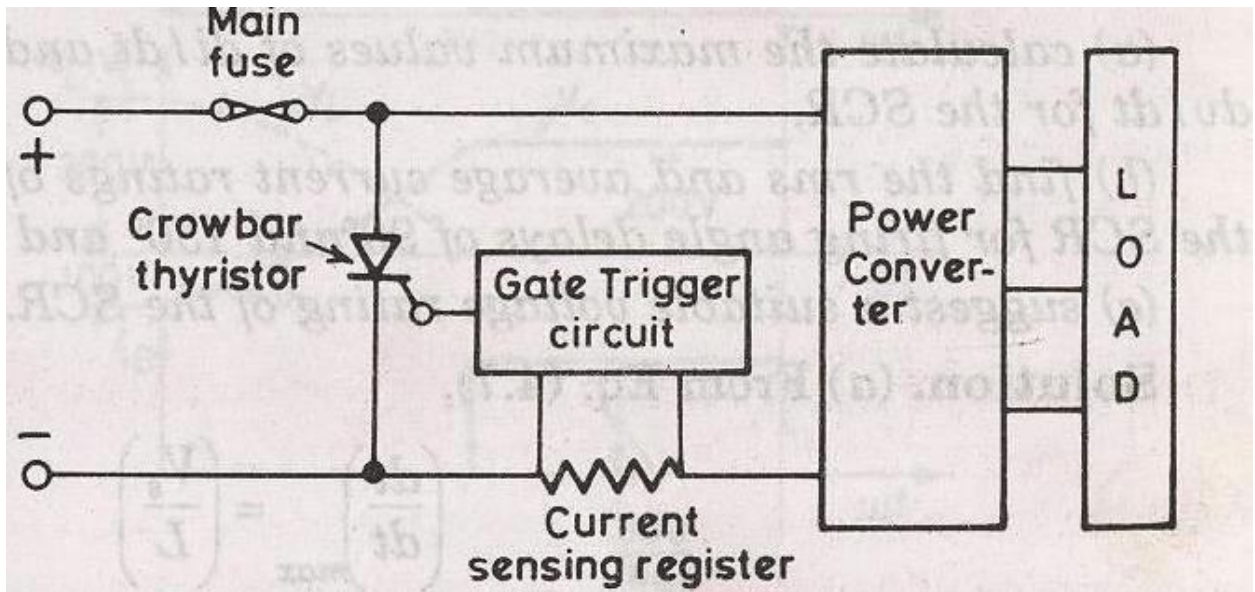

HEAT PROTECTION-

To protect the SCR

1. From the local spots
 2. Temp rise
- SCRs are mounted over heat sinks.

GATE PROTECTION-

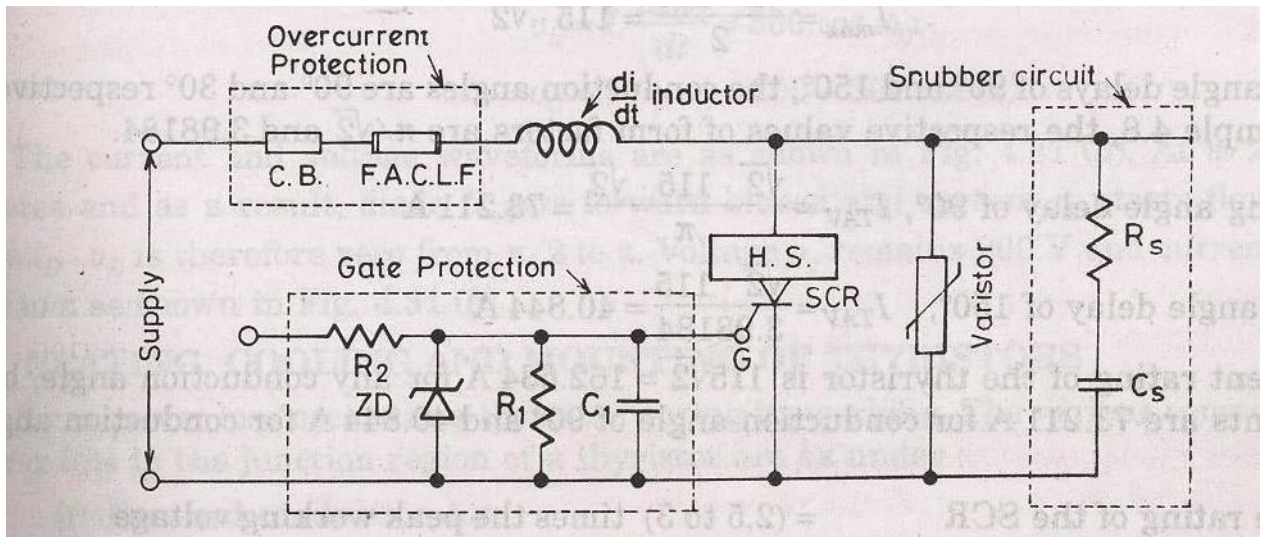

Gate circuit should also be protected from

1. Overvoltages
2. Overcurrents

Overvoltage across the gate circuit causes the false triggering of SCR

Overcurrent raise the junction temperature. Overvoltage protection is by zener diode across the gate circuit.

INSULATED GATE BIPOLAR TRANSISTOR(IGBT)-

BASIC CONSTRUCTION-

The n+ layer substrate at the drain in the power MOSFET is substituted by p+ layer substrate and called as collector. When gate to emitter voltage is positive, n- channel is formed in the p- region. This n- channel short circuit the n- and n+ layer and an electron movement in n channel cause hole injection from p+ substrate layer to n- layer.

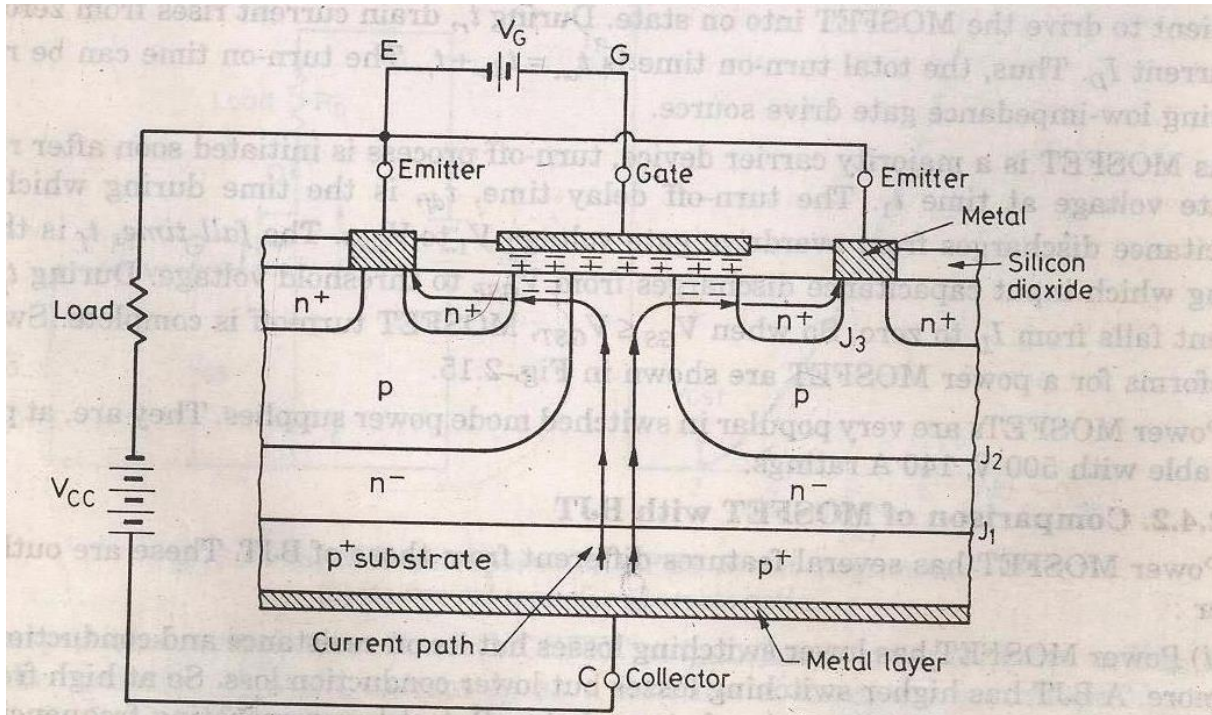

POWER MOSFET

A power MOSFET has three terminal device. Arrow indicates the direction of current flow. MOSFET is a voltage controlled device. The operation of MOSFET depends on flow of majority carriers only.

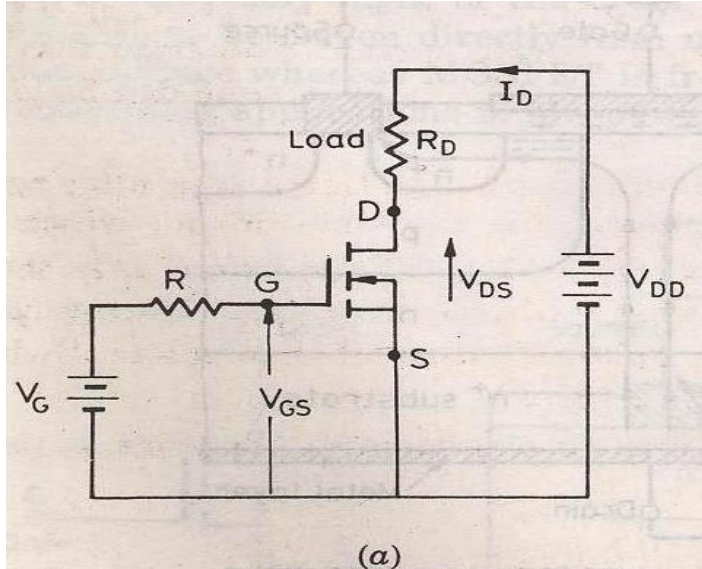

(Circuit diagram)

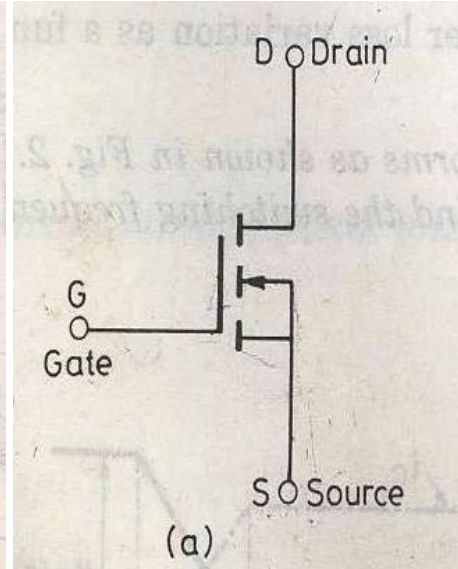

(circuit symbol)

Switching Characteristics:-

The switching characteristic is influenced by

1. Internal capacitance of the device.
2. Internal impedance of the gate drive circuit.

Total **turn on time** is divided into

1. Turn on delay time
2. Rise time

Turn on time is affected by impedance of gate drive source. During turn on delay time gate to source voltage attains its threshold value V_{GST} .

After t_{dn} and during rise time gate to source voltage rise to V_{Gsp} , a voltage which is sufficient to drive the MOSFET to ON state.

The turn off process is initiated by removing the gate to source voltage. Turn off time is composed of turn off delay time to fall time.

Turn off delay time

To turn off the MOSFET the input capacitance has to be discharged . During t_{df} the input capacitance discharge from V_1 to V_{GSP} . During t_f , fall time ,the input capacitance discharges from V_{GSP} to V_{GST} . During t_f drain current falls from I_D to zero.

So when $V_{GS} \leq V_{GST}$, MOFSET turn off is complete.

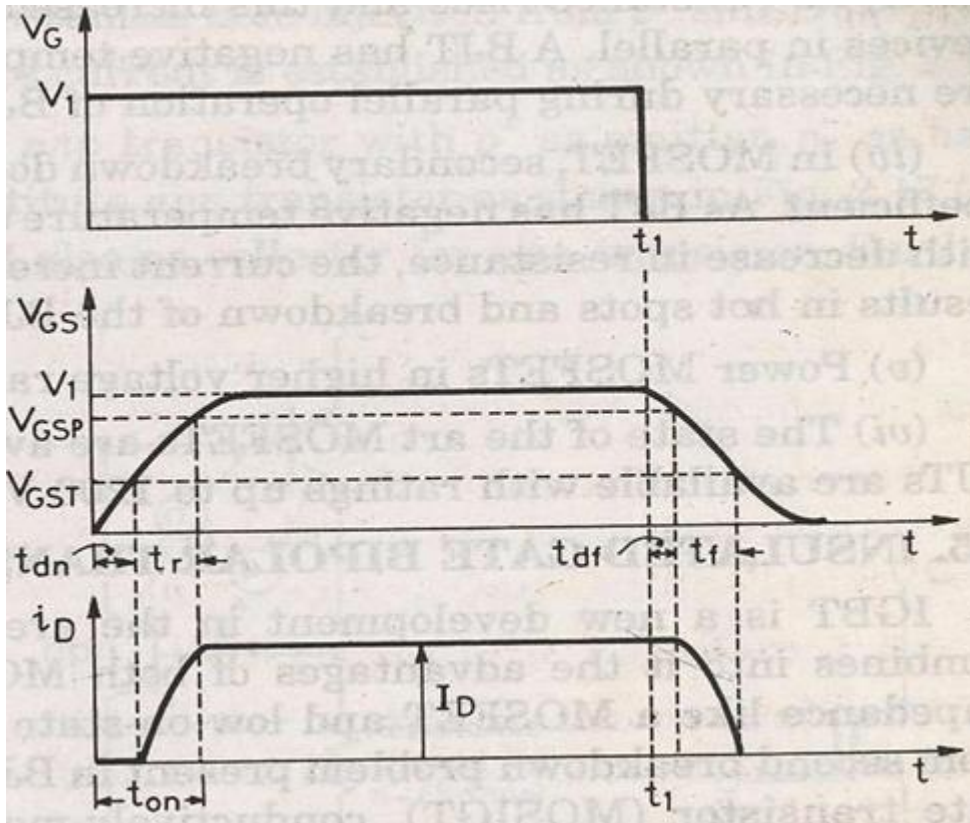

Fig. Switching waveform of power MOSFET

Insulated Gate Bipolar Transistor (IGBT)

IGBT has high input impedance like MOFFSET and low on state power lose as in BJT.

IGBT Characteristics

Here the controlling parameter is gate emitter voltage As IGBT is a voltage controlled device.

When V_{GE} is less than V_{GET} that is gate emitter threshold voltage IGBT is in off state.

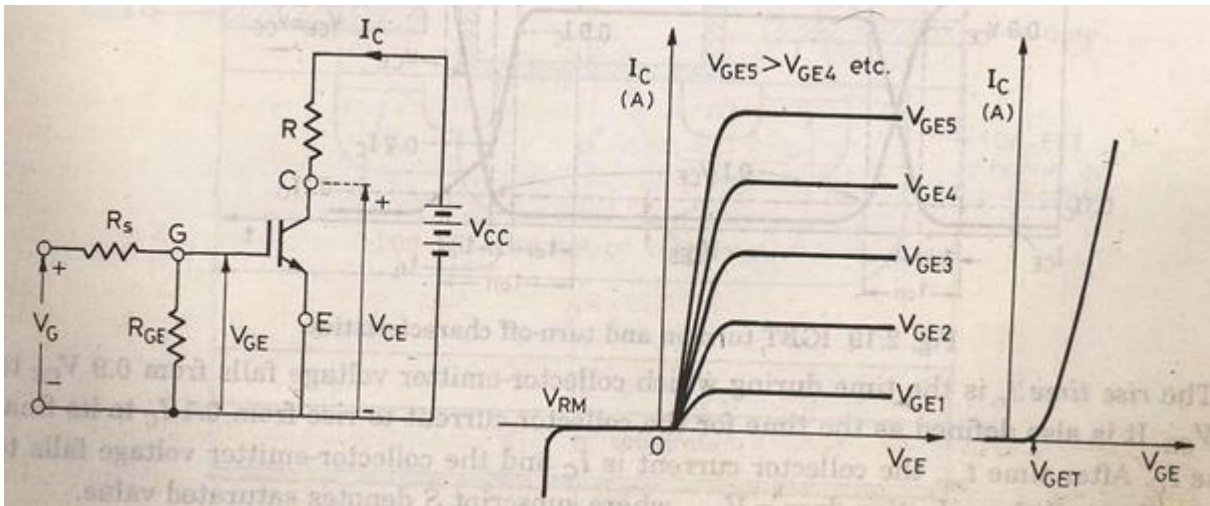

Fig. a

Fig. b.

Fig. c

Fig. a (Circuit diagram for obtaining V-I characteristics)

Fig. b (Static V-I characteristics)

Fig. c (Transfer characteristic)

Switching characteristics: Figure below shows the turn ON and turn OFF characteristics of IGBT

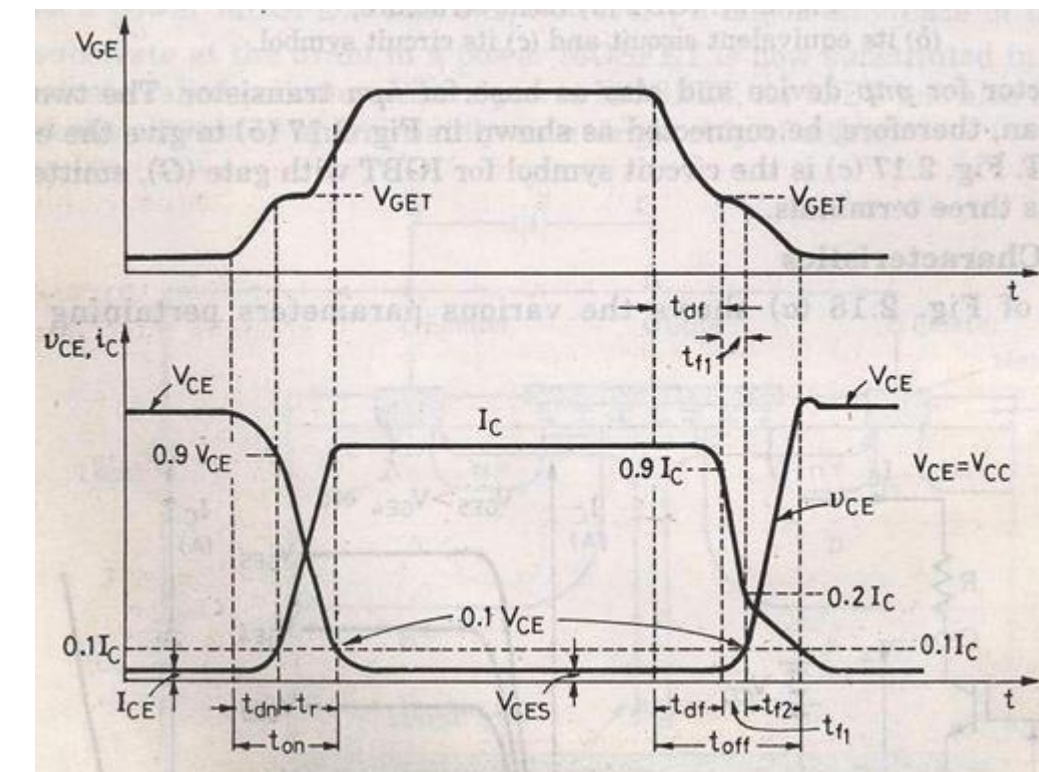

Turn on time

Time between the instants forward blocking state to forward on -state .

Turn on time = Delay time + Rise time

Delay time = Time for collector emitter voltage fall from V_{CE} to $0.9V_{CE}$

V_{CE} =Initial collector emitter voltage

t_{dn} =collector current to rise from initial leakage current to $0.1I_c$

I_c = Final value of collector current

Rise time

Collector emitter voltage to fall from $0.9V_{CE}$ to $0.1V_{CE}$.

I_c to I_c

After t_{on} the device is on state the device carries a steady current of I_c and the collector emitter voltage falls to a small value called conduction drop V_{CES} .

Turn off time

- 1) Delay time t_{df}
- 2) Initial fall time t_{f1}
- 3) Final fall time t_{f2}

$$t_{off} = t_{df} + t_{f1} + t_{f2}$$

t_{df} = Time during which the gate emitter voltage falls to the threshold value V_{GET} .

Collector current falls from I_c to $0.9I_c$ at the end of the t_{df} collector emitter voltage begins to rise.

Turn off time = Collector current falls from 90% to 20% of its initial value I_c OR The time during which collector emitter voltage rise from V_{CE} to $0.1V_{CE}$.

t_{f2} = collector current falls from 20% to 10% of I_c .

During this collector emitter voltage rise $0.1V_{CE}$ to final value of V_{CE} .

Series and parallel operation of SCR

SCR are connected in series for h.v demand and in parallel for fulfilling high current demand. String efficiency can be defined as measure of the degree of utilization on SCRs in a string.

String efficiency < 1 .

Derating factor (DRF)

1 – string efficiency.

If DRF more then

no. of SCRs will more, so string is more reliable.

Let the rated blocking voltage of the string of a series connected SCR is $2V_1$ as shown in the figure below, But in the string two SCRs are supplied a maximum voltage of V_1+V_2 .

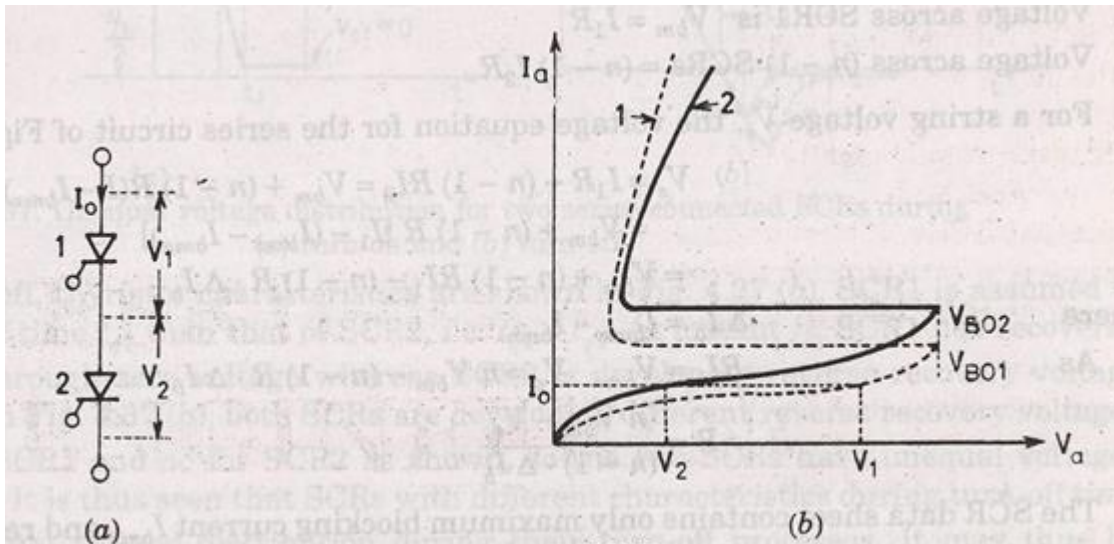

$$\eta = \frac{V_1 + V_2}{2V_1}$$

Significance of string efficiency.

Two SCRs are have same forward blocking voltage ,When system voltage is more then the voltage rating of a single SCR. SCRs are connected in series in a string.

There is a inherent variation in characteristics. So voltage shared by each SCR may not be equal. Suppose, SCR1 leakage resistance > SCR2 leakage resistance. For same leakage current I_0 in the series connected SCRs. For same leakage current SCR1 supports a voltage V_1 , SCR2 supports a voltage V_2 ,

So string η for two SCRs = $\frac{V_1+V_2}{2V_1} = \frac{1}{2}(1 + \frac{V_2}{V_1}) < 1$.

So, $V_1 > V_2$,

The above operation is when SCRs are not turned ON. But in steady state of operation , A uniform voltage distribution in the state can be achieved by connect a suitable resistance across each SCRs , so that parallel combination have same resistance.

But this is a cumbersome work. During steady state operation we connect same value of shunt resistance across each SCRs. This shunt resistance is called **state equalizing circuit**.

Suppose,

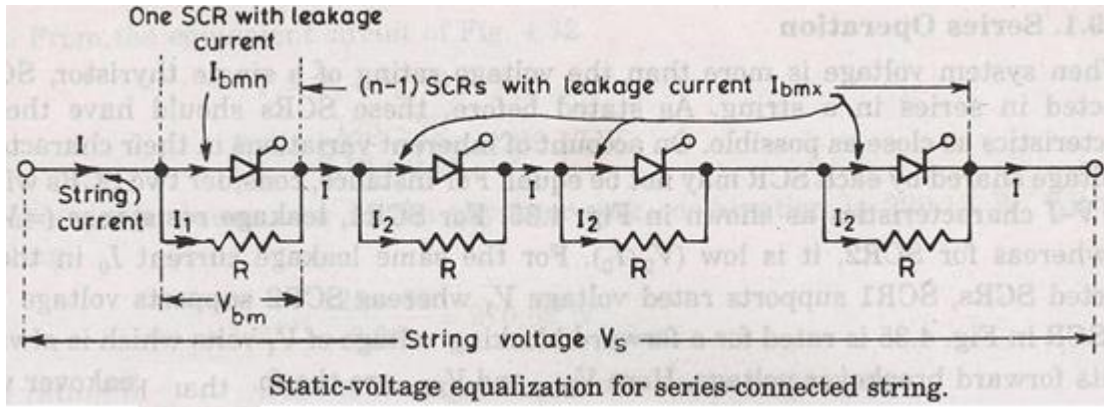

Let SCR1 has lower leakage current I_{bm} , It will block a voltage comparatively larger than other SCRs.

Voltage across SCR1 is $V_{bm} = I_1 R$.

Voltage across (n-1)SCR is (n-1) $I_2 R$, so the voltage equation for the series circuit is $V_s = I_1 R + (n - 1) I_2 R = V_{bm} + (n-1) R (I - I_{bmx})$

As $I_1 = I - I_{bmn}$

$$I_2 = I - I_{bmx}$$

So, $V_s = V_{bm} + (n-1) R [I_1 - (I_{bmx} - I_{bmn})]$

If $\Delta I_b = I_{bmx} - I_{bmn}$

Then $V_s = V_{bm} + (n-1) R (I_1 - \Delta I_b)$

$V_s = V_{bm} + (n-1) R I_1 - (n-1) R \Delta I_b$

$R I_1 = V_{bm}$

So, $V_s = V_{bm} + (n-1) V_{bm} - (n-1) R \Delta I_b$

$$= n V_{bm} - (n-1) R \Delta I_b$$

$$\Rightarrow R = \frac{n V_{bm} - V_s}{(n-1) \Delta I_b}$$

SCR data sheet usually contain only maximum blocking current, I_{bmx}

so we assume $I_{bmn} = 0$

So $\Delta I_b = I_{bmx}$

So the value of R calculated is low than actually required.

SCRs having unequal dynamic characteristics:

It may occur that SCRS may have unequal dynamic characteristics so the voltage distribution across the SCR may be unequal during the transient condition.

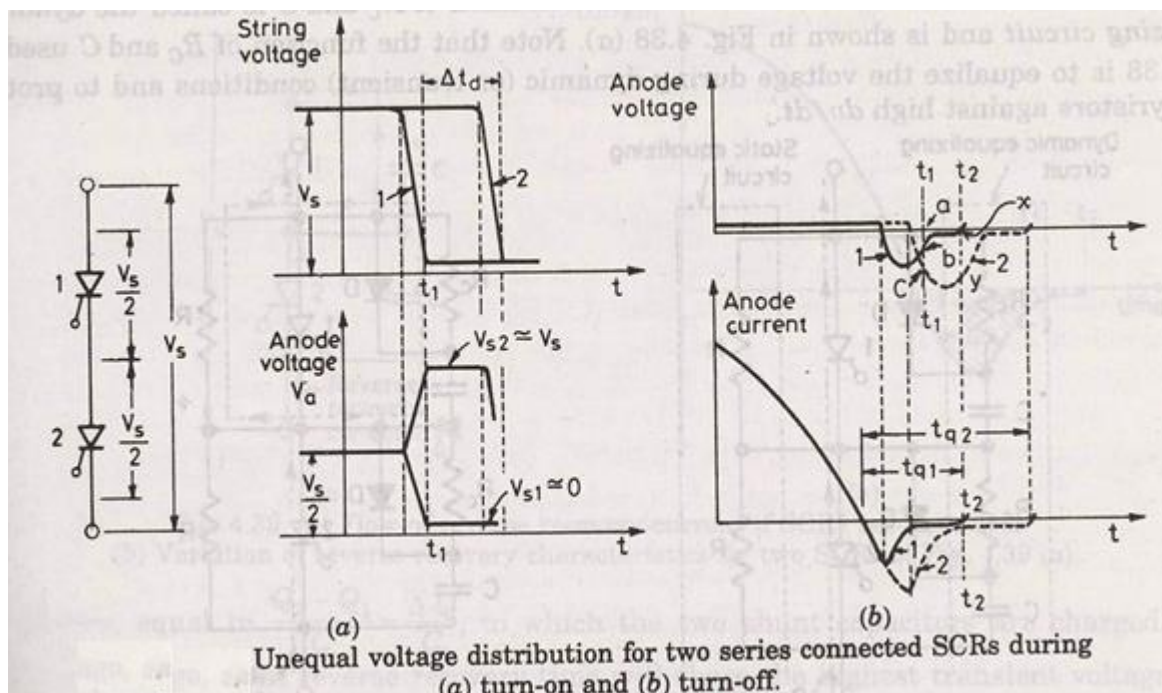

SCR 1 and SCR 2 have different dynamic characteristics. Turn ON time of SCR 2 is more than SCR 1 by time Δt .

As string voltage is V_s so voltage shared by each SCRs be $V_s/2$. Now both are gated at same time so SCR 1 will turn ON at t_1 its voltage fall nearly to zero so the voltage shared by SCR 2 will be the string voltage if the break over voltage of SCR 2 is less than V_s then SCR 2 will turn ON.

* In case V_s is less than the breakover voltage, SCR 2 will turn ON at instant 2. SCR 1 assumed to have less turn off t_{q1} time then SCR 2, so $t_{q1} < t_{q2}$. At t_2 SCR 1 has recovered while SCR 2 is developing recovery voltage at t_1 both are developing different reverse recovery voltage. At t_2 SCR 1 has recovered while SCR2 is developing reverse recovery voltage.

Conclusion :

* Series connected SCR develop different voltages during turn ON and turn OFF process. Till now we connect a simple resistor across the diode for static voltage equalizing circuit.

* During turn ON and turn OFF capacitance of reverse biased junction determine the voltage distribution across SCRs in a series connected string. As reverse biased junction have different capacitance called *self capacitance*, the voltage distribution during turn ON and turn Off process would be different.

* Under transient condition equal voltage distribution can be achieved by employing shunt capacitance as this shunt capacitance has the effect of that the resultant of shunt and self capacitance tend to be equal. The capacitor is used to limit the dv/dt across the SCR during forward blocking state. When this SCR turned ON capacitor discharges heavy current through the SCR. The discharge current spike is limited by damping resistor R_c . R_c also damps out high frequency oscillation that may arise due to series combination of R , C and series inductor. R_c & C are called *dynamic equalizing circuit*

Diode D is used during forward biased condition for more effective charging of the capacitor. During capacitor discharge R_c comes into action for limiting current spike and rate of change of current di/dt .

The R , R_c & C component also provide path to flow reverse recovery current. When one SCR regain its voltage blocking capability. The flow of reverse recovery current is necessary as it facilitates the turning OFF process of series connected SCR string. So C is necessary for both during turn ON and turn OFF process. But the voltage unbalance during turn OFF time is more predominant than turn ON time. So choice of C is based on reverse recovery characteristic of SCR.

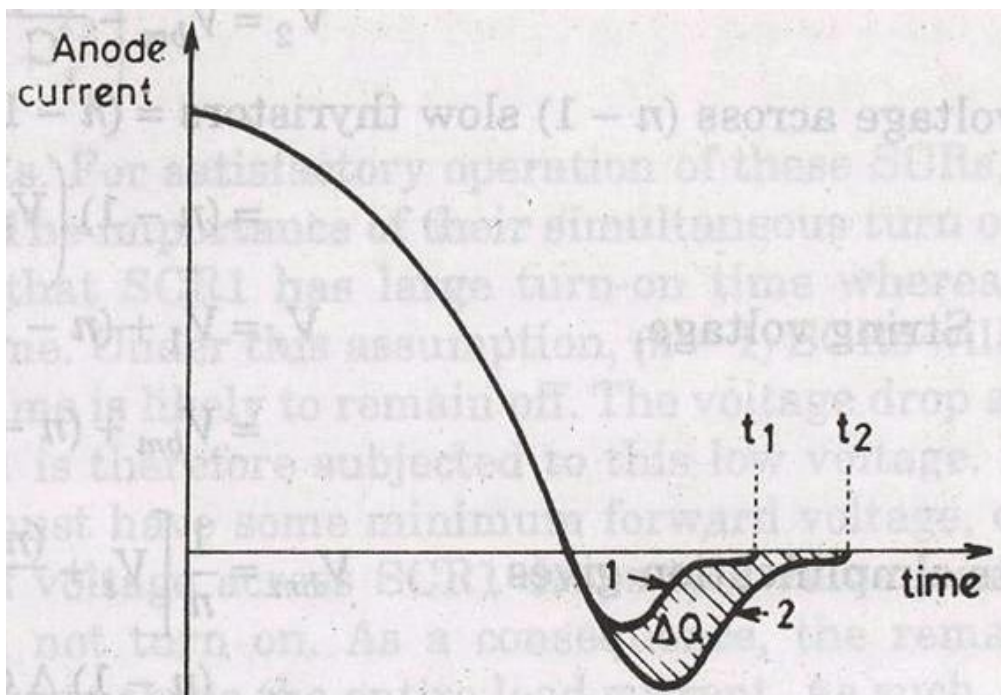

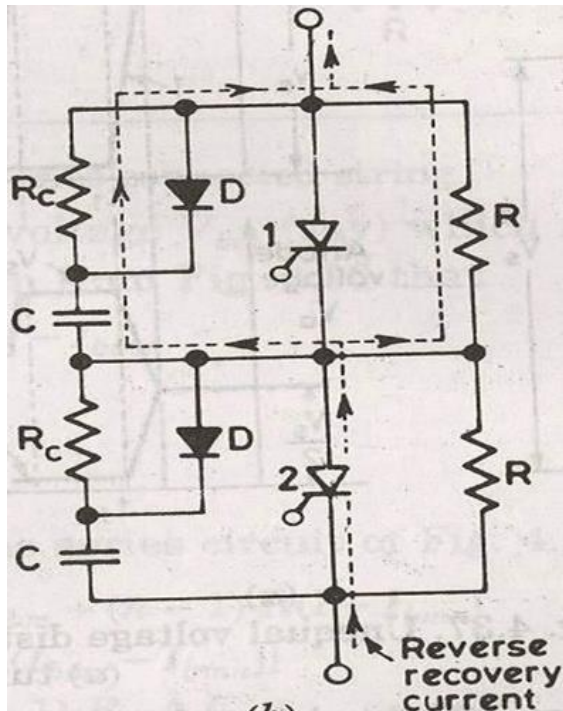

SCR 1 has short recovery time as compared to SCR 2. ΔQ is the difference in reverse recovery charges of two SCR 1 and SCR 2. Now we assume the SCR 1 recovers fast . i.e it goes into blocking state so charge ΔQ can pass through C . The voltage induced by c_1 is $\Delta Q/C$, where is no voltage induced across C_2 .

The difference in voltage to which the two shunt capacitor are charged is $\Delta Q/C$.

Now thyristor with least recovery time will share the highest transient voltage say V_{bm} ,

$$\text{So, } V_{bm} - V_2 = \Delta Q/C$$

$$\text{So, } V_2 = V_{bm} - \Delta Q/C$$

$$\text{As } V_1 = V_{bm}$$

$$V_s = V_1 + V_2$$

$$= V_{bm} + (V_{bm} - \Delta Q/C)$$

$$V_s = 2V_{bm} - \Delta Q/C$$

$$\Rightarrow \frac{1}{2} \left(V_s + \frac{\Delta Q}{C} \right) = V_{bm}$$

$$\Rightarrow V_2 = V_{bm} - \Delta Q/C$$

$$\frac{1}{2} [V_s - \Delta Q/C]$$

Now suppose that there are n series SCRs in a string.

Let us assume that if top SCR has similar to characteristic SCR 1. Then SCR 1 would support a voltage V_{bm}

* If the remaining $(n-1)$ SCR has characteristic that of SCR 2. Then SCR 1 would recover first and support a voltage V_{bm} . The charge $(n-1) \Delta Q$ from the remaining $(n-1)$ SCR would pass through C.

$$V_1 = V_{bm}$$

$$V_2 = V_{bm} - \Delta Q/C$$

Voltage across $(n-1)$ slow thyristors

$$V = (n-1) (V_{bm} - \Delta Q/C)$$

So,
$$V_S = V_1 + (n-1) V_2$$

$$= V_{bm} + (n-1) (V_{bm} - \Delta Q/C)$$

By simplifying we get ,

$$V_{bm} = \frac{1}{n} [V_S + (n-1) \Delta Q/C]$$

$$C = [(n-1) \Delta Q / (nV_{bm} - V_S)]$$

$$V_2 = (V_S - \Delta Q/C) / n .$$

Parallel operation:

When current required by the load is more than the rated current of single thyristor , SCRs are connected in parallel in a string .

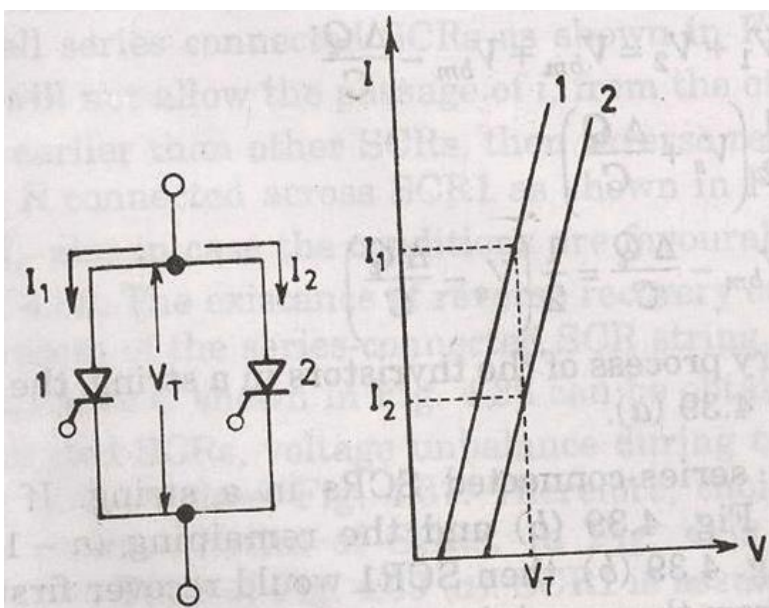

For equal sharing of current, SCRs must have same $V - I$ characteristics during forward conduction. V_T across them must be same. For same V , SCR 1 share I_1 and SCR 2 share I_2 .

If I_1 is the rated current

$$I_2 < I_1$$

The total current $I_1 + I_2$ and not rated current $2I_1$. Type equation here.

Thus string efficiency,

$$\frac{I_1 + I_2}{2I_1} = \frac{1}{2} \left(1 + \frac{I_2}{I_1} \right)$$

Middle conductor will have more inductance as compared to other two nearby conductor. As a result less current flow through the middle conductor. Another method is by magnetic coupling.

Thyristor gate characteristics:-

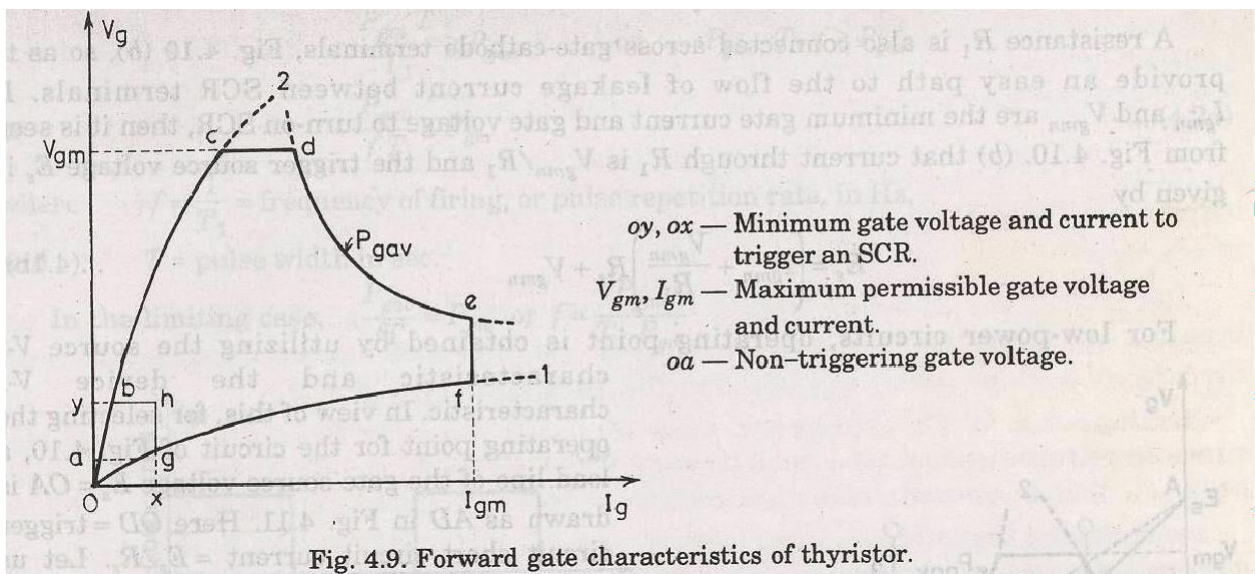

$V_g = +ve$ gate to cathode voltage.

$I_g = +ve$ gate to cathode current.

As the gate cathode characteristic of a thyristor is a p-n junction, gate characteristic of the device is similar to diode.

Curve 1 the lowest voltage value s that must be applied to turn on the SCR.

Curve 2 highest possible voltage values that can be safely applied to get circuit.

V_{gm} = Maximum limit for gate voltage .

I_{gm} = Maximum limit for gate current.

P_{gav} = Rated gate power dissipation for each SCR.

These limits should not be crossed in order to avoid the permanent damage of the device junction J_3 .

OY = Minimum limit of gate voltage to turn ON .

OX = minimum limit of gate current to turn ON.

If V_{gm} , I_{gm} , P_{gav} are exceeded the thyristor will damage so the preferred gate drive area of SCR is bcdefghb.

oa = The non triggering gate voltage , If firing circuit generates +ve gate signal prior to the desired instant of triggering the SCR. It should be ensured that this unwanted signal should be less than the non-triggering voltage oa.

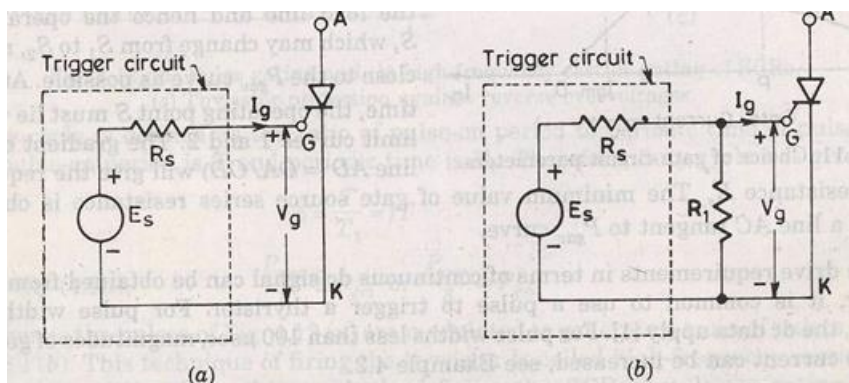

$$E_s = V_g + I_g R_s$$

E_s = Gate source voltage

V_g = Gate cathode voltage

I_g = Gate current

R_s = Gate source resistance

R_s = The internal resistance of the trigger source

R_1 is connected across the gate cathode terminal, which provides an easy path to the flow of leakage current between SCR terminal. If I_{gmn} , V_{gmn} are the minimum gate current and gate voltage to turn ON the SCR.

$$E_s = (I_{gmn} + V_{gmn}/R_1) R_s + V_{gmn}$$

MODULE-II

RECTIFIER

Rectifier are used to convert A.C to D.C supply.

Rectifiers can be classified as single phase rectifier and three phase rectifier. Single phase rectifier are classified as 1- Φ half wave and 1- Φ full wave rectifier. Three phase rectifier are classified as 3- Φ half wave rectifier and 3- Φ full wave rectifier. 1- Φ Full wave rectifier are classified as 1- Φ mid point type and 1- Φ bridge type rectifier. 1- Φ bridge type rectifier are classified as 1- Φ half controlled and 1- Φ full controlled rectifier. 3- Φ full wave rectifier are again classified as 3- Φ mid point type and 3- Φ bridge type rectifier. 3- Φ bridge type rectifier are again divided as 3- Φ half controlled rectifier and 3- Φ full controlled rectifier.

Single phase half wave circuit with R-L load

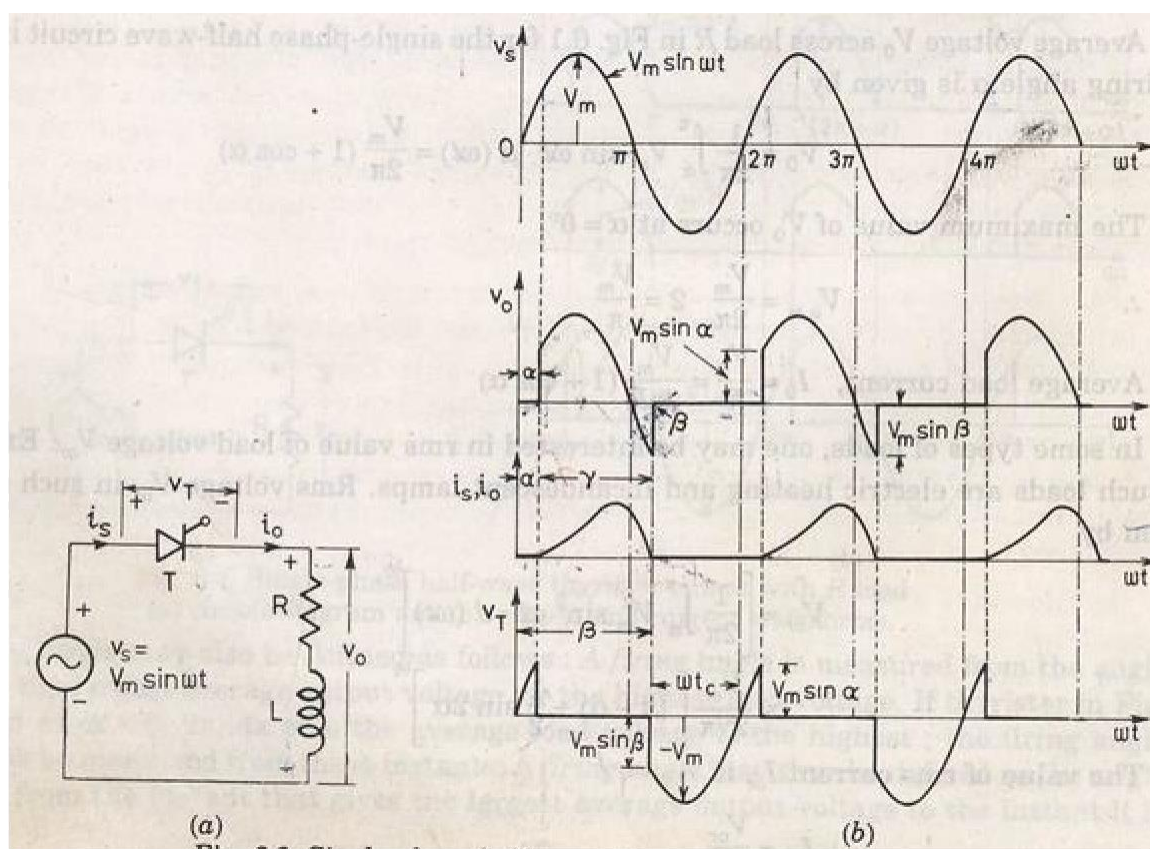

Output current i_o rises gradually. After some time i_o reaches a maximum value and then begins to decrease.

At π , $v_o = 0$ but i_o is not zero because of the load inductance L . After π interval SCR is reverse biased but load current is not less than the holding current.

At $\beta > \pi$, i_o reduces to zero and SCR is turned off.

At $2\pi + \beta$ SCR triggers again

α is the firing angle.

β is the extinction angle.

$$v = \beta - \alpha = \text{conduction angle}$$

Analysis for V_T .

$$\text{At } \omega t = \alpha, V_T = V_m \sin \alpha$$

$$\text{During } \alpha \text{ to } \beta, V_T = 0;$$

$$\text{When } \omega t = \beta, V_T = V_m \sin \beta;$$

$$V_m \sin \omega t = Ri_0 + L \frac{di_0}{dt}$$

$$i_s = \frac{V_m}{\sqrt{R^2 + X^2}} \sin(\omega t - \phi)$$

Where,

$$\phi = \tan^{-1} \frac{X}{R}$$

$$X = \omega L$$

Where ϕ is the angle by which I_s lags V_s .

The transient component can be obtained as

$$Ri_t + L \frac{di_t}{dt} = 0$$

$$\text{So } i_t = Ae^{-(Rt/L)}$$

$$i_0 = i_s + i_t$$

$$\frac{V_m}{Z} \sin(\omega t - \alpha) + Ae^{-(Rt/L)}$$

$$\text{Where } z = \sqrt{R^2 + X^2}$$

$$\text{At } \alpha = \omega t, i_o = 0;$$

$$0 = \frac{V_m}{z} \sin(\alpha - \alpha) + Ae^{-(R\alpha/L\omega)};$$

$$A = \frac{-V_m}{z} \sin(\alpha - \alpha) e^{(R\alpha/L\omega)}$$

$$i = \frac{V_m}{z} \sin(\omega t - \alpha) - \frac{V_m}{z} \sin(\alpha - \alpha) e^{-R(\omega t - \alpha)/L\omega}$$

Therefore,

$$\omega t = \beta, i_o = 0;$$

$$\text{So } \sin(\beta - \alpha) = \sin(\alpha - \beta)e^{-(\beta - \alpha)/(\omega L)}$$

β can be obtained from the above equation.

The average load voltage can be given by

$$V_0 = \frac{1}{2\pi} \int_{\alpha}^{\beta} V_m \sin \omega t d(\omega t)$$

$$\frac{V_m}{2\pi} (\cos(\alpha) - \cos(\beta))$$

Average load current

$$I_0 = \frac{V_m}{2\pi R} (\cos \alpha - \cos \beta)$$

Single phase full converter

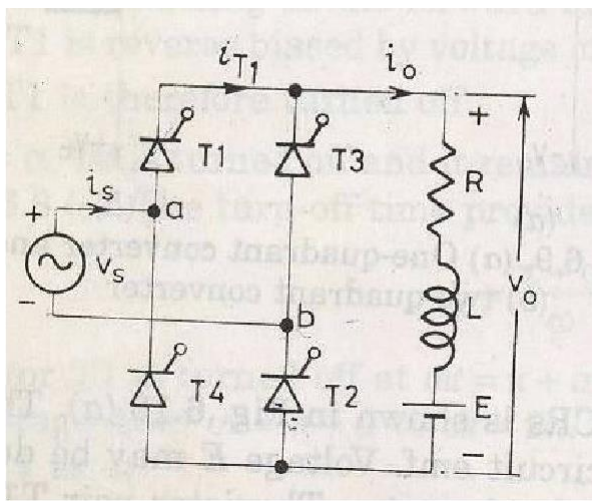

$$V_0 = \frac{1}{\pi} \int_{\alpha}^{\pi + \beta} V_m \sin(\omega t) d(\omega t)$$

$$= \frac{2V_m}{\pi} \cos \alpha$$

T_1, T_2 triggered at α and π radian latter T_3, T_4 are triggered.

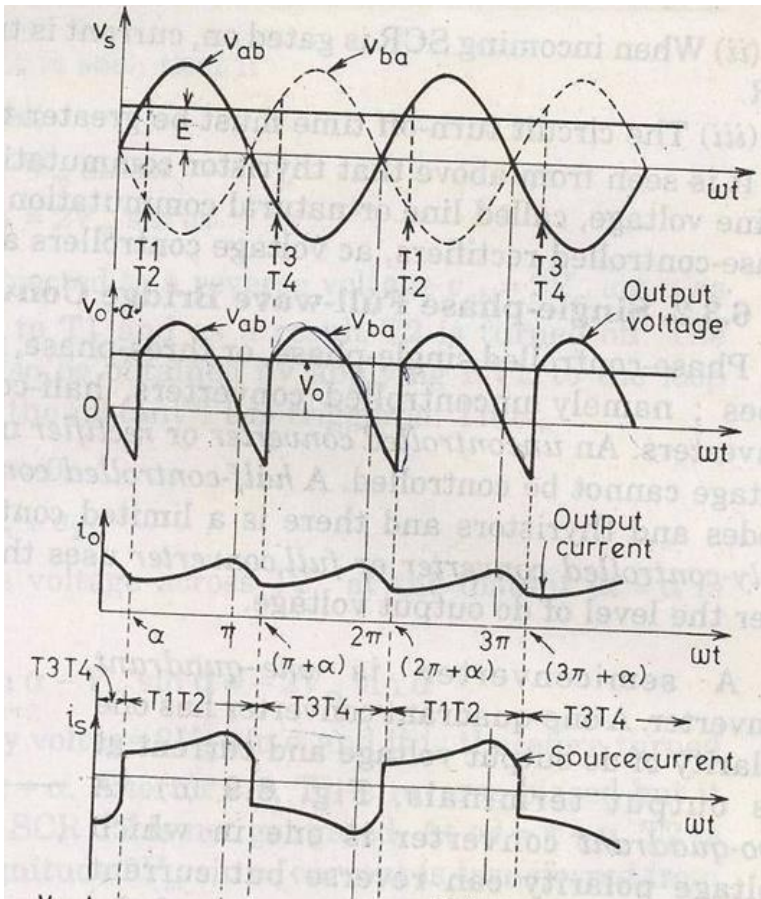

Single phase half wave circuit with RLE load

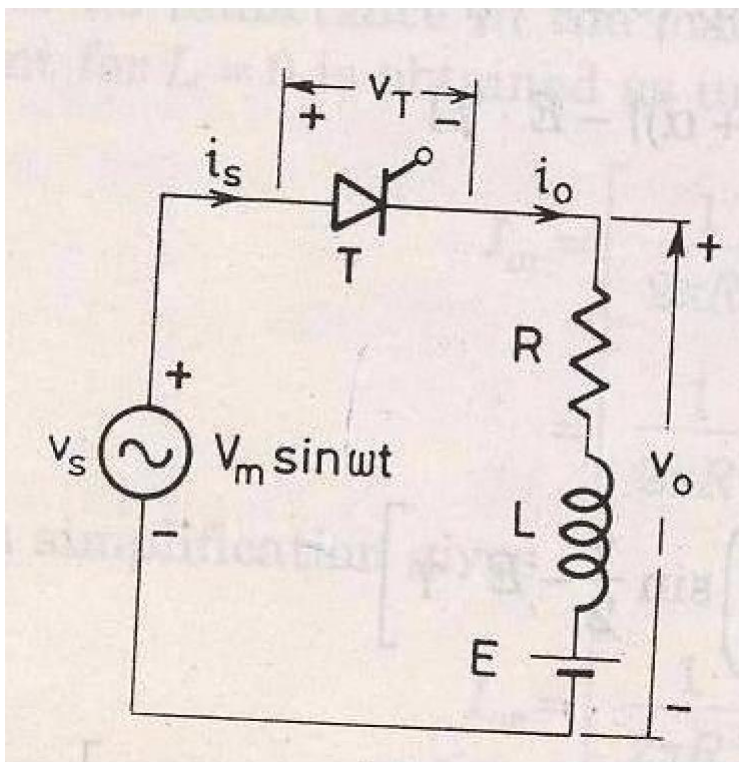

The minimum value of firing angle is

$$V_m \sin(\omega t) = E$$

So,

$$\theta_1 = \sin^{-1} \frac{E}{V_m}$$

Maximum value of firing angle

$$\theta_2 = \pi - \theta_1$$

The voltage differential equation is

$$V_m \sin(\omega t) = Ri_0 + L \frac{di_0}{dt} + E$$

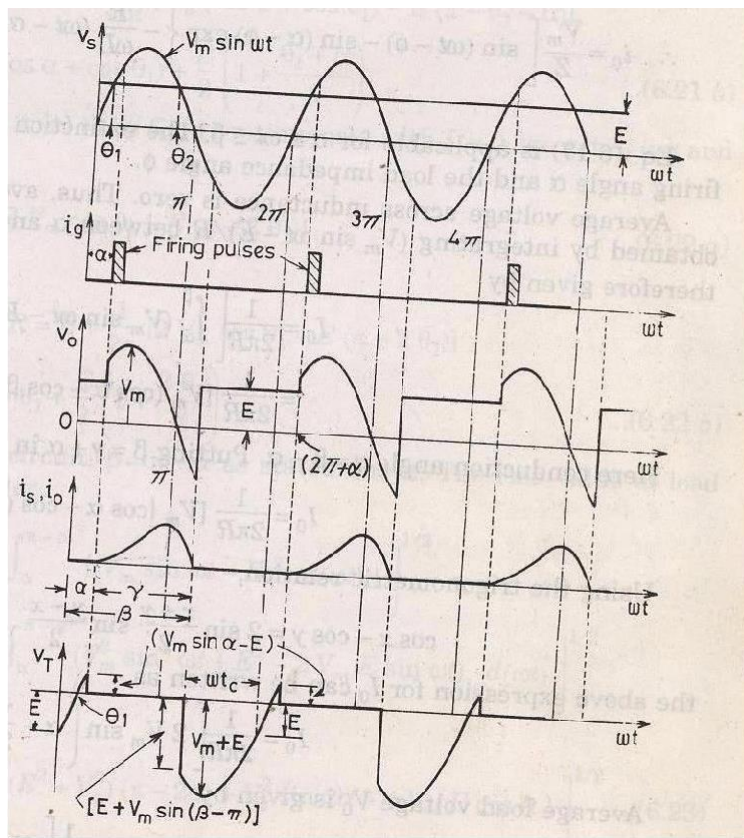

$$i_s = i_{s1} + i_{s2}$$

Due to source volt

$$i_{s1} = \frac{V_m}{Z} \sin(\omega t - \phi)$$

Due to DC counter emf

$$i_{s2} = -(E/R)$$

$$i_t = Ae^{-(R/L)t}$$

Thus the total current is given by

$$i_{s1} + i_{s2} + i_t$$

$$= \frac{V_m}{Z} \sin(\omega t - \phi) - \frac{E}{R} + Ae^{-(R/L)t}$$

$$i_{s0} = \frac{V_m}{Z} \sin(\omega t - \phi) - \frac{E}{R} + Ae^{-(R/L)t}$$

$$At\omega t = \alpha, i_0 = 0$$

$$A = \left[\frac{E}{R} - \frac{V_m}{Z} \sin(\alpha - \phi) \right] e^{-R\alpha/L\omega}$$

So

$$i_0 = \frac{V_m}{Z} \left[\sin(\omega t - \phi) - \sin(\alpha - \phi) e^{\frac{-R}{\omega L}(\omega t - \alpha)} - \frac{E}{R} \left[1 - e^{\frac{-R}{\omega L}(\omega t - \alpha)} \right] \right]$$

Average voltage across the inductance is zero. Average value of load current is

$$I = \frac{1}{2\pi R} \int_{\alpha}^{\beta} (V_m \sin \omega t - E) d(\omega t)$$

$$= \frac{1}{2\pi R} [V_m (\cos \alpha - \cos \beta) - E(\beta - \alpha)]$$

Conduction angle $v = \beta - \alpha$

$$\Rightarrow \beta = \alpha + v$$

$$I = \frac{1}{2\pi R} [V_m (\cos \alpha - \cos(\alpha + v)) - E(v)]$$

$$\cos A - \cos B = 2 \sin \frac{A+B}{2} \sin \frac{A-B}{2}$$

So

$$I = \frac{1}{2\pi R} \left[2V_m \sin\left(\alpha + \frac{v}{2}\right) \sin \frac{v}{2} - E.v \right]$$

$$v = E + I_0 R$$

$$= E + \frac{1}{2\pi} [2V_m \sin(\alpha + \frac{v}{2}) \sin \frac{v}{2} - E \cdot v]$$

$$= E(1 - \frac{v}{2\pi}) + [\frac{V_m}{\pi} \sin(\alpha + \frac{v}{2}) \sin \frac{v}{2}]$$

If load inductance L is zero then

$$\beta = \theta_2$$

$$\text{And } v = \beta - \alpha = \theta_2 - \alpha$$

$$\text{But } \theta_2 = \pi - \theta_1$$

$$\text{So } \beta = \theta_2 = \pi - \theta_1$$

$$\text{And } v = \pi - \theta_1 - \alpha$$

So average current will be

$$I_0 = \frac{1}{2\pi R} [V_m (\cos \alpha - \cos(\pi - \theta_1)) - E(\pi - \theta_1 - \alpha)]$$

So $V_0 = E + I_0 R$

$$= \frac{V_m}{2\pi} (\cos \alpha + \cos \theta_1) + \frac{E}{2} (1 + \frac{\theta_1 + \alpha}{\pi})$$

For no inductance rms value of load current

$$I_0 = \left[\frac{1}{2\pi R^2} \int_{\alpha}^{\pi - \alpha} (V_m \sin(\omega t) - E)^2 d(\omega t) \right]^{1/2}$$

Power delivered to load

$$P = I_0^2 R + I_0 E$$

Supply power factor

$$Pf = \frac{I_0^2 R + I_0 E}{V_s I_0}$$

Single phase full wave converter:

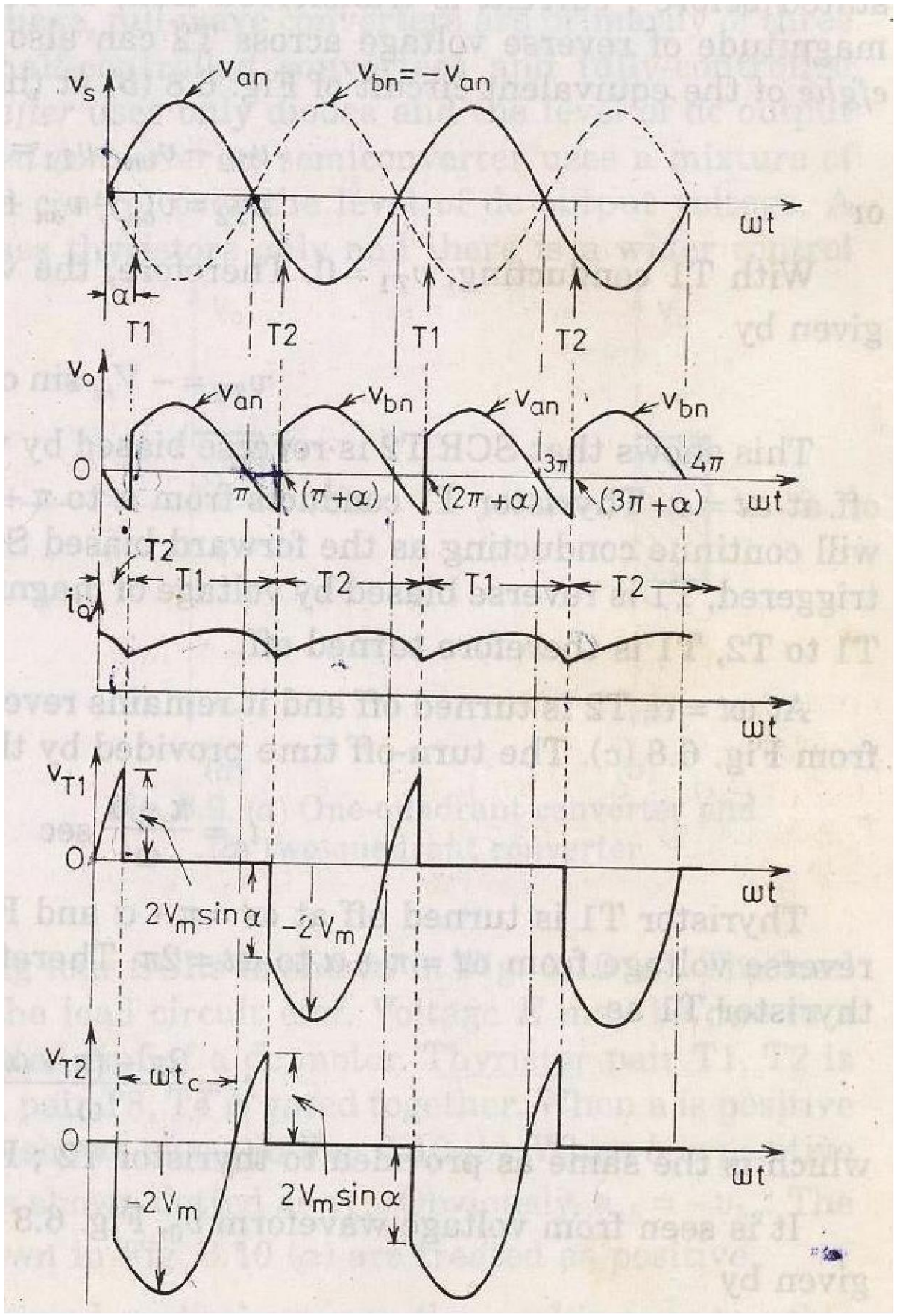

$$V = \frac{1}{\pi} \int_{\alpha}^{\pi+\alpha} V_m \sin(\omega t) d(\omega t)$$

$$= \frac{2V_m}{\pi} \sin\alpha$$

Single phase semi converter:

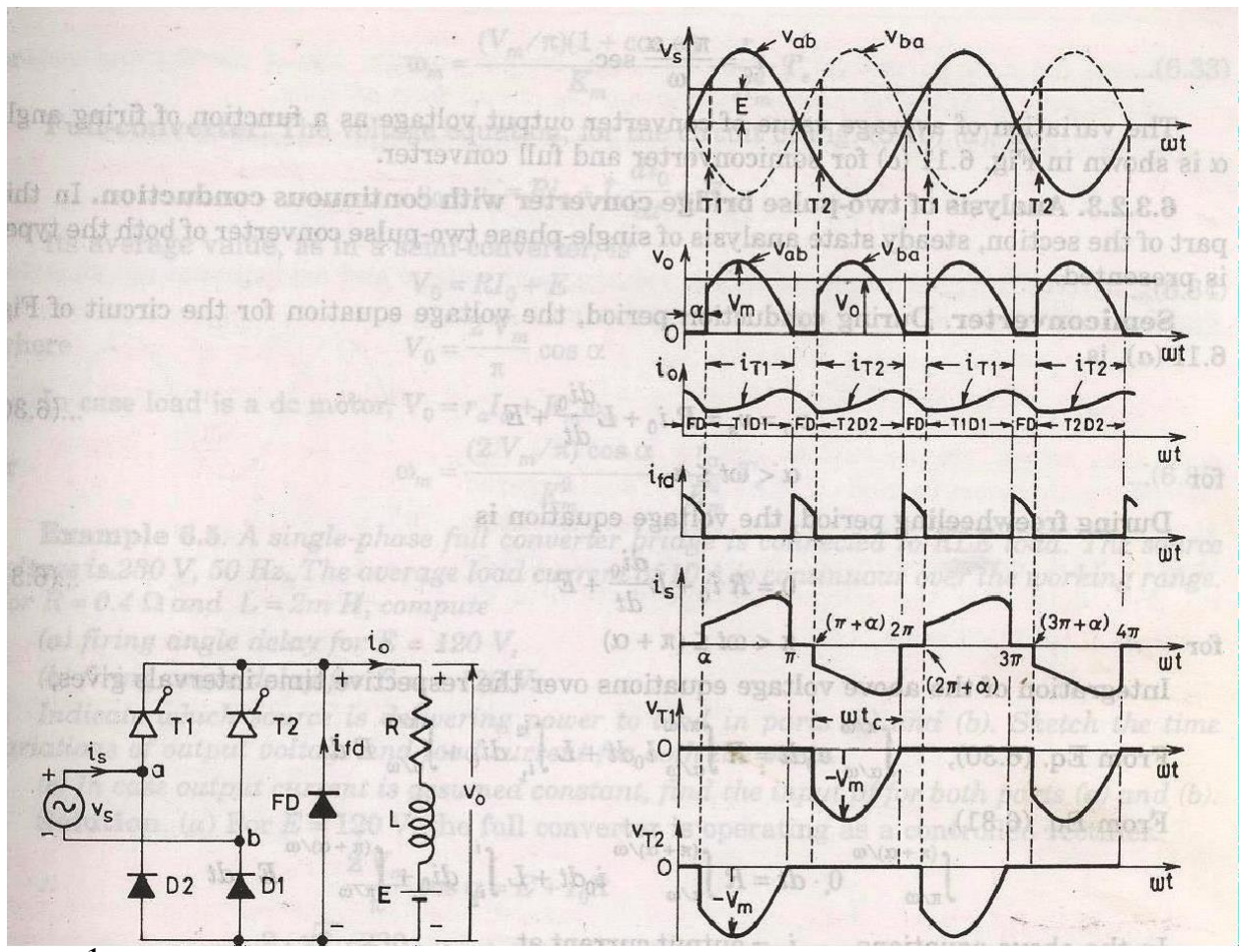

$$V = \frac{1}{\pi} \int_{\alpha}^{\pi} V_m \sin(\omega t) d(\omega t)$$

$$= \frac{V_m}{\pi} \cos\alpha$$

full converter:

steady state analysis

$$V = R_i + L \frac{di_0}{dt} + E$$

$$V_0 = RI_0 + E$$

$$V_0 = \frac{2V_m}{\pi} \cos\alpha$$

So in case of DC motor load

$$V_0 = r_a I_a + \alpha_m \omega_m$$

$$\omega_m = \frac{\frac{2V_m}{\pi} \cos\alpha - r_a I_a}{\alpha_m}$$

So

$$T = \alpha_m I_a$$

$$\Rightarrow I_a = \frac{T_e}{\alpha_m}$$

$$I_a = \frac{T_e}{\alpha_m}$$

Put

$$\omega_m = \frac{\pi}{\alpha_m} \left(\frac{2V_m}{\pi} \right) \cos\alpha - \frac{r_a T_e}{\alpha_m^2}$$

So

MODULE - III

CHOPPER

A chopper is a static device that converts fixed DC input voltage to variable output voltage directly. Chopper are mostly used in electric vehicle, mini haulers.

Chopper are used for speed control and braking. The systems employing chopper offer smooth control, high efficiency and have fast response.

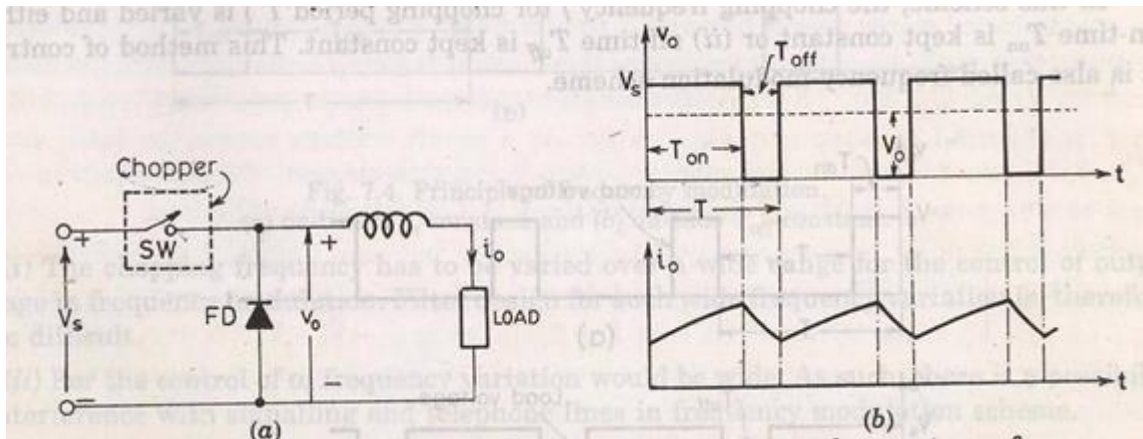

The average output voltage is

$$V_a = \frac{1}{T} \int_0^T V_o dt = \frac{1}{T} V_s (t_1) = f t_1 V_s = \alpha V_s$$

The average load current

$$I_a = \frac{V_a}{R} = \frac{\alpha V_s}{R}$$

Where, T=chopping period

Duty cycle of chopper =

$$\alpha = \frac{t_1}{T}$$

f=chopping frequency

The rms value of output voltage is

$$V = \left(\frac{1}{T} \int_0^T V_o^2 dt \right)^{1/2} = \sqrt{\alpha} V_s$$

If we consider the converter to be loss less then the input power is equal to the output power and is given by

$$P_i = \frac{1}{T} \int_0^{\alpha T} V_0 i dt = \frac{1}{T} \int_0^{\alpha T} \frac{V_0^2}{R} dt$$

$$= \frac{1}{T} \frac{V_0^2}{R} (\alpha T) = \frac{\alpha V_0^2}{R}$$

The effective input resistance seen by the P source is

$$P = \frac{V_s}{I_a} = \frac{V_s}{\frac{\alpha V_s}{R}} = \frac{R}{\alpha}$$

The duty cycle α can be varied by varying t_1 , T of frequency.

Constant frequency operation:

1) The chopping period T is kept constant and on time is varied.

The pulse width modulation, the width of the pulse is varied.

2) Variable frequency operation, the chopping frequency f is varied.

Frequency modulation, either on time or off time is kept constant.

This type of control generate harmonics at unpredictable frequency and filter design is often difficult.

TYPES OF CHOPPER:

FIRST QUADRANT OR TYPE A CHOPPER:

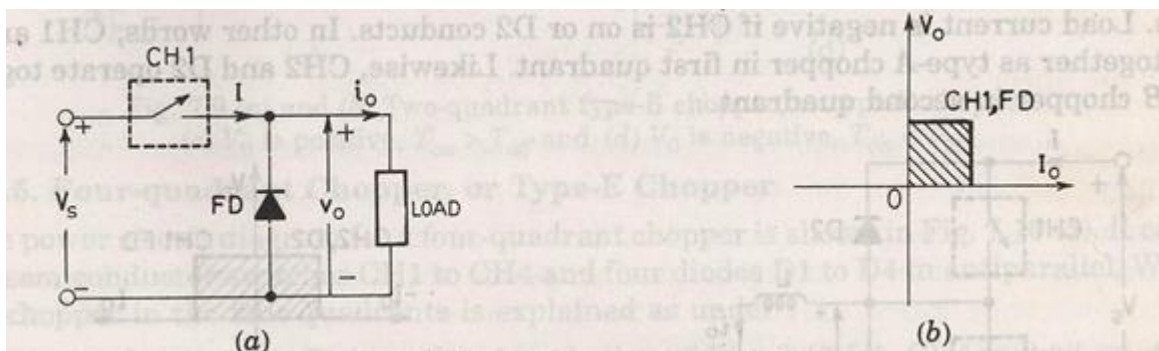

When switch ON

$$V_0 = V_s$$

Current i_o flows in the same direction when switch off.

$$V_o=0, i_o=0$$

So, average value of both the load and the current are positive.

SECOND QUADRANT OR TYPE B CHOPPER:

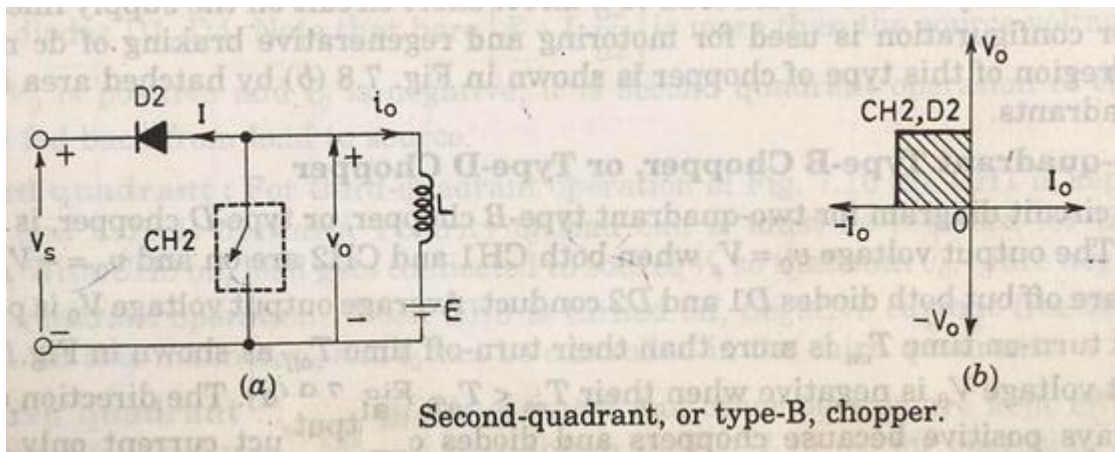

When switch are closed the load voltage E drives current through L and switch. During T_{on}

L stores energy.

When switch off V_o exceeds source voltage V_s .

$$V_o = E + L \frac{di}{dt}$$

Diode D_2 is forward biased. power is fed back to supply. As V_o is more than source voltage. So such chopper is called step up chopper.

$$V_o = E + L \frac{di}{dt}$$

So current is always negative and V_o is always positive.

TWO QUADRANT TYPE A CHOPPER OR, TYPE C CHOPPER:

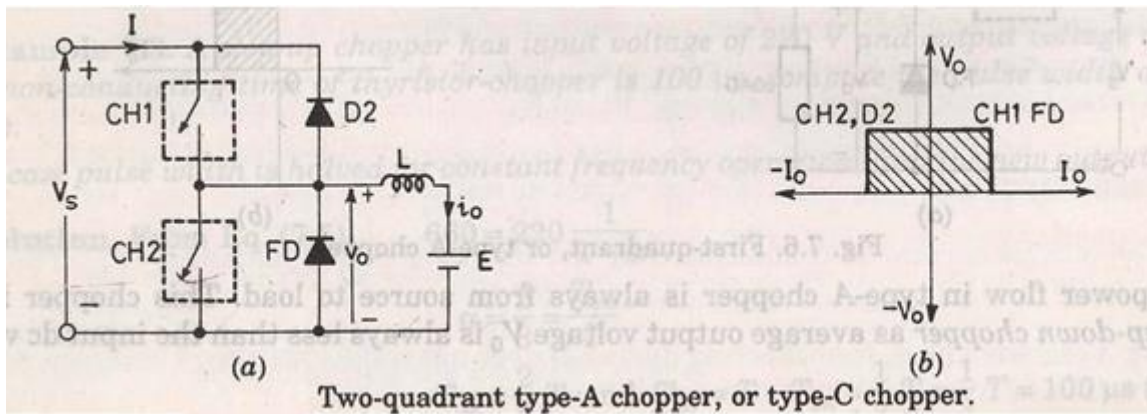

Both the switches never switch ON simultaneously as it lead direct short circuit of the supply.

Now when sw2 is closed or FD is on the output voltage V_o is zero.

When sw1 is ON or diode D conducts output voltage is V_o is $+V_s'$

CURRENT ANALYSIS:

When CH1 is ON current flows along i_o . When CH1 is off current continues to flow along i_o as FD is forward biased. So i_o is positive.

Now when CH2 is ON current direction will be opposite to i_o . When sw2 is off D2 turns ON.

Load current is $-i_o$. So average load voltage is always positive. Average load current may be positive or negative.

TWO QUADRANT TYPE B CHOPPER, OR TYPE D CHOPPER:

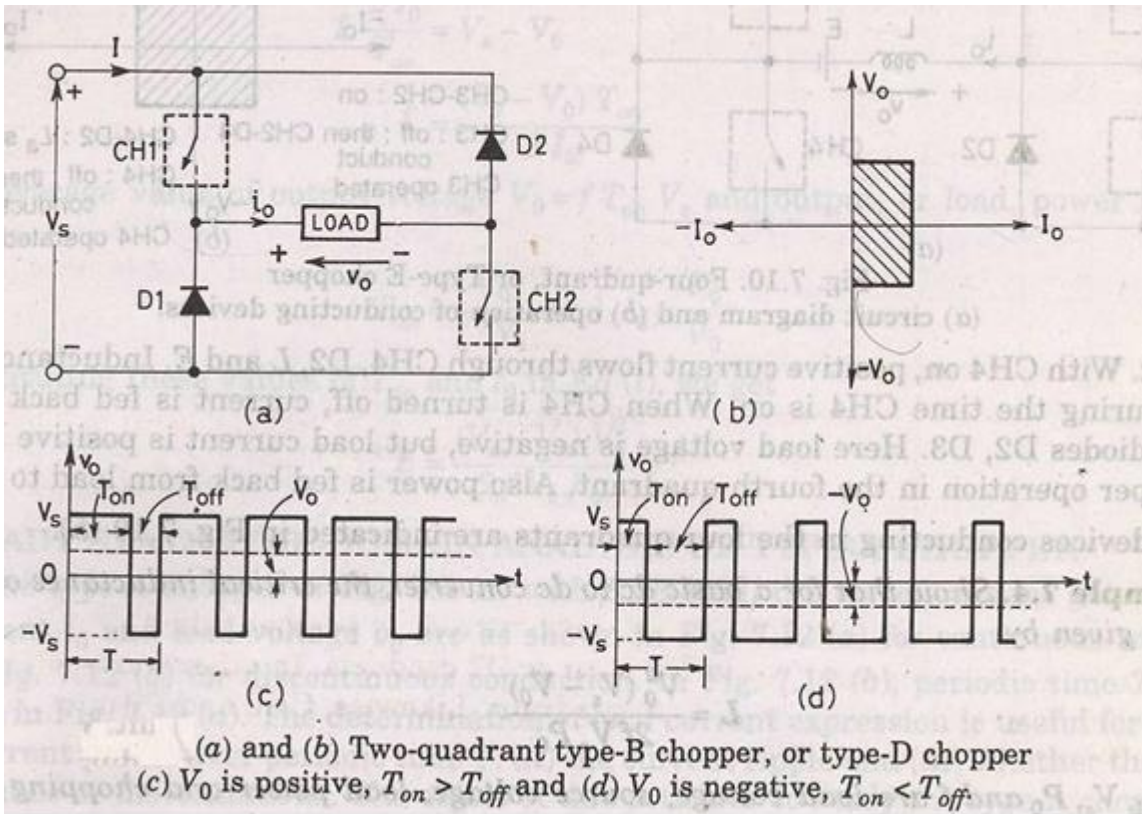

When CH1 and CH2 both are on then $V_0 = V_s$.

When CH1 and CH2 are off and D1 and D2 are on $V_0 = -V_s$.

The direction of current is always positive because chopper and diode can only conduct in the direction of arrow shown in fig.

Average voltage is positive when $T_{on} > T_{off}$

FOUR QUADRANT CHOPPER, OR TYPE E CHOPPER

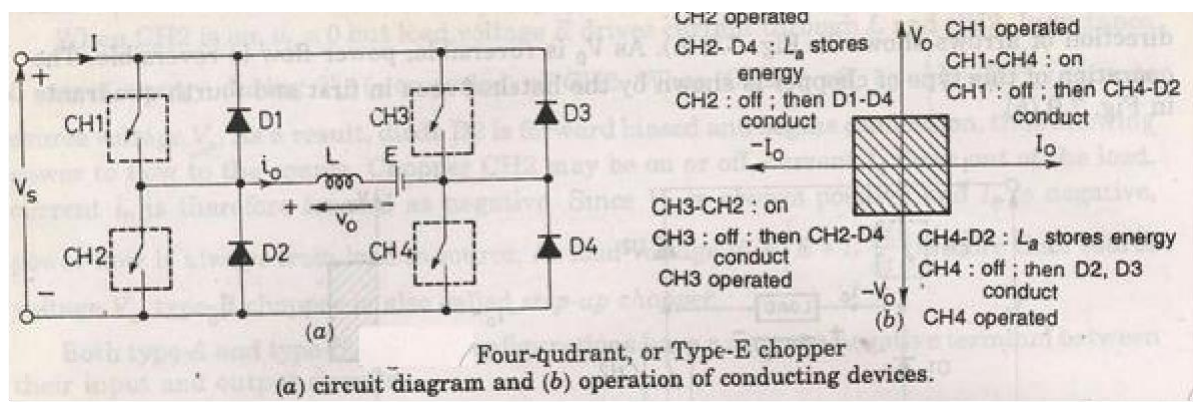

FIRST QUADRANT:

CH4 is kept ON

CH3 is off

CH1 is operated

$$V_0 = V_s$$

$i_0 =$ positive

when CH1 is off positive current free wheels through CH4, D2

so V_0 and I_2 is in first quadrant.

SECOND QUADRANT:

CH1, CH3, CH4 are off.

CH2 is operated.

Reverse current flows and I is negative through L CH2 D4 and E.

When CH2 off D1 and D4 is ON and current i_d fed back to source. So

$$E + L \frac{di}{dt} \text{ is more than source } V_s.$$

As i_0 is negative and V_0 is positive, so second quadrant operation.

THIRD QUADRANT:

CH1 OFF, CH2 ON

CH3 operated. So both V_0 and i_0 is negative.

When CH3 turned off negative current freewheels through CH2 and D4.

FOURTH QUADRANT:

CH4 is operated other are off.

Positive current flows through CH4 E L D2.

Inductance L stores energy when current fed to source through D3 and D2. V_0 is negative.

STEADY STATE ANALYSIS OF PRACTICAL BUCK CHOPPER:

The voltage across the inductor L is $e_L = L di/dt$.

$$V_s - V_a = L \frac{d(i_2 - i_1)}{dt_1} = L \frac{\Delta i}{t_1}$$

$$t_1 = \frac{\Delta i L}{V_s - V_a}$$

The inductor current falls linearly from I_2 to I_1 in time t_2 as $V_s = 0$.

So

$$-V_a = \frac{L(i_1 - i_2)}{t_2}$$

If $I_2 - I_1 = \Delta I$ then

$$-V_a = -\frac{L\Delta I}{t_2}$$

$$t_2 = \frac{L\Delta I}{V_a}$$

$\Delta I = I_2 - I_1 =$ peak to peak ripple current.

$$\Delta I = \frac{(V_s - V_a)t_1}{L} = \frac{V_a t_2}{L}$$

Now $t_1 = \alpha T$, $t_2 = (1 - \alpha)T$

$$V_a = V_s \frac{t_1}{T} = \alpha V_s$$

$\alpha < 1$ so it is a step down or buck converter.

If the circuit is lossless then $V_s I_s = V_a I_a = \alpha V_s I_a$

$$I_s = \alpha I_a$$

Now switching period T can be expressed as

$$T=1/f= t_1+ t_2=\Delta I L/(V_s-V_a) + \Delta I L/(V_a)$$

$$=\Delta I L V_s/V_a(V_s-V_a)$$

So peak to peak ripple current

$$\Delta I = \frac{V_a(V_s-V_a)}{fL V_s}$$

$$\Delta I = \frac{V_a \alpha(1-\alpha)}{fL}$$

The peak to peak voltage of the capacitor is

$$\Delta V_c = \frac{\Delta I}{8fc}$$

So from above equation

$$\Delta V_c = \frac{V_a(V_s-V_a)}{8Lcf^2 V_s} \cdot \frac{V_s \alpha(1-\alpha)}{8Lcf^2}$$

Condition for continuous inductor current and capacitor voltage :

If I_L is the average inductor current

$$\Delta I_L = 2I_L \dots \text{as}$$

$$V_a = \alpha V_s$$

$$\frac{V_s \alpha(1-\alpha)}{fL} =$$

$$\text{As } \frac{I_2 - I_1}{2} = I_L$$

$$\text{So } \Delta I = 2I_L$$

$$\frac{V_s \alpha(1-\alpha)}{fL} \dots \text{eq (2)}$$

$$\frac{V_s \alpha(1-\alpha)}{fL} = 2I_L = 2I_a = \frac{2\alpha V_s}{R} \dots \text{eq(4)}$$

$$\text{As } V_a = \alpha V_s \text{ so } I_a = \frac{\alpha V_s}{R}$$

$$2I_a = \frac{2\alpha V_s}{R}$$

So equation 4 gives

$$L_c = \frac{(1-\alpha)R}{2f}$$

Which is the critical value of inductor

$$\Delta V_c = 2V_a$$

$$2V_a = \frac{V_s \alpha (1-\alpha)}{8L_c f^2} = 2\alpha V_s$$

$$c = \frac{1-\alpha}{16L_c f^2}$$

Peak to peak ripple voltage of capacitor:

$$\begin{aligned} \Delta V_c &= V_c - V_c(t=0) \\ &= \int_0^{t_1} I_c dt = \int_0^{t_1} I_a dt = \frac{I_a t_1}{c} \end{aligned}$$

$$\text{So } t_1 = \frac{V_a - V_s}{V_{af}}$$

$$t_1 = \frac{V_a - V_s}{V_{af}}$$

$$\Rightarrow 1 - \alpha = \frac{V_s}{V_a}$$

$$\Rightarrow 1 - \frac{t_1}{T} = \frac{V_s}{V_a}$$

$$\Rightarrow t_1 = \frac{V_a - V_s}{V_a f}$$

$$\text{So } \Delta V_c = \frac{I_a}{c} \left(\frac{V_a - V_s}{V_{af}} \right)$$

$$\Rightarrow \Delta V_c = \frac{I_a \alpha}{fc}$$

Condition for continuous inductor current and capacitor voltage:

If I_L = average inductor current then

$$I_L = \frac{\Delta I}{2}$$

$$\Delta I = \frac{V_s \alpha}{fL} = 2I_L = 2I_a = \frac{2V_s}{(1-\alpha)R}$$

As $V_a = \frac{V_s}{1-\alpha}$

$$\Rightarrow 2I_a = \frac{2V_s}{(1-\alpha)R}$$

So $\Delta I_L = 2I_L = 2I_a = \frac{2V_s}{(1-\alpha)R} = \frac{V_s \alpha}{fL}$

$$\Rightarrow L_c = \frac{\alpha(1-\alpha)R}{2f}$$

$$\Delta V_c = 2V_a$$

$$\frac{I_a \alpha}{cf} = 2V_a = 2I_a R$$

$$c = \frac{\alpha}{2fR}$$

MODULE – IV

INVERTERS

The device that converts dc power into ac power at desired output voltage and frequency is called an inverter.

Single phase voltage source inverters

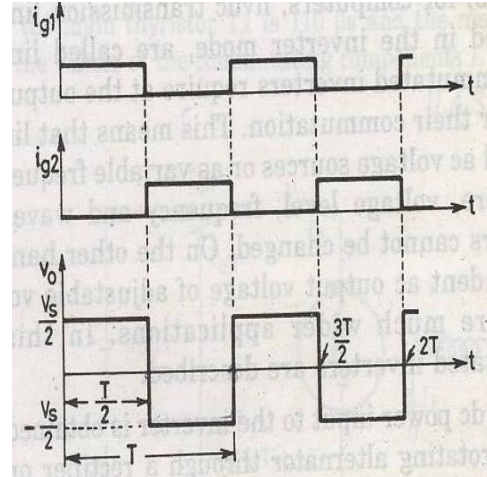
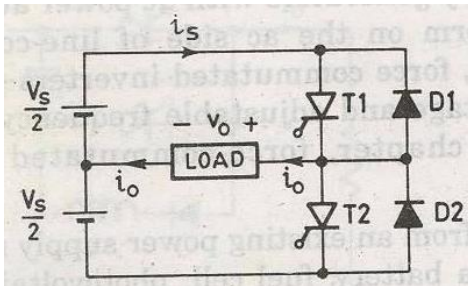

$$V_o(\text{rms}) = \frac{1}{T} \int_0^{T/2} \frac{V_s}{2} dt = \frac{V_s}{2}$$

$$V_o = \frac{a_0}{2} + \sum_{n=1}^{\infty} (a_n \cos(n\omega t) + b_n \sin(n\omega t))$$

Due to symmetry along x-axis

$$a_0 = 0, a_n = 0$$

$$b_n = \frac{4V_s}{n\pi}$$

The instantaneous output voltage

$$v_o = \sum_{n=1,3,5,\dots}^{\infty} \frac{2V_s}{n\pi} \sin(n\omega t)$$

$$= 0, \quad n=2,4,\dots$$

$$= 0, \quad n=2,4,\dots$$

The rms value of the fundamental output voltage

$$V_{o1} = \frac{2V_s}{\sqrt{2}\pi} = 0.45V_s$$

$$\text{So if } V_0 = \sum_{n=1,3,5,\dots}^{\infty} \frac{2VS}{n\pi} \sin(n\omega t)$$

$$= \sum_{n=1,3,5,\dots}^{\infty} \frac{2VS}{n\pi\sqrt{R^2+(n\omega L)^2}} \sin(n\omega t - \theta_n)$$

$$P_{01} = (I_{01})^2 R = \left[\frac{2VS}{\sqrt{2\pi}\sqrt{R^2+(n\omega L)^2}} \right]^2 R$$

DC Supply Current

Assuming a lossless inverter, the ac power absorbed by the load must be equal to the average power supplied by the dc source.

$$\int_0^T i_s(t) dt = \frac{1}{V_s} \int_0^T \sqrt{2} V_{01} \sin(\omega t) \sqrt{2} I_0 \sin(\omega t - \theta_1) dt = I_s$$

V_{01} = Fundamental rms output voltage

I_0 = rms load current

θ_1 = the load angle at the fundamental frequency

Single phase full bridge inverter

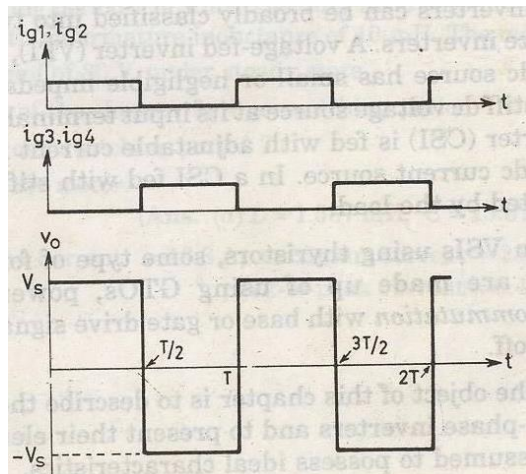
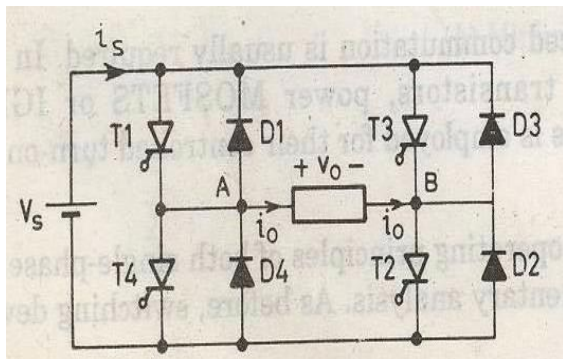

For $n=1$, $V_1 = \frac{4VS}{\sqrt{2\pi}} = 0.9V_s$ (The rms of fundamental)

Instantaneous load current i_0 for an RL load

$$i_0 = \sum_{n=1,3,5,\dots}^{\infty} \frac{4VS}{n\pi\sqrt{R^2+(n\omega L)^2}} \sin(n\omega t - \theta_n)$$

$$\theta_n = \tan^{-1}\left(\frac{n\omega L}{R}\right)$$

The rms output voltage is

$$V = \left(\frac{2}{T_0} \int_0^{T/2} V^2 dt \right)^{1/2} = V_s$$

The instantaneous output voltage in a fourier series

$$v_0 = \sum_{n=1,3,5,\dots}^{\infty} \frac{4V_s}{n\pi} \sin(n\omega t)$$

Single phase bridge inverter

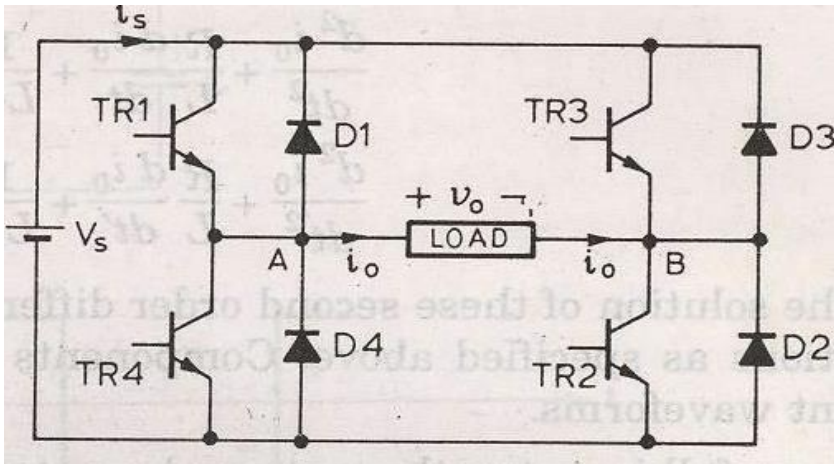

INVERTER

Inverters are of the two types

- 1) VSI
- 2) CSI

Pulse width model

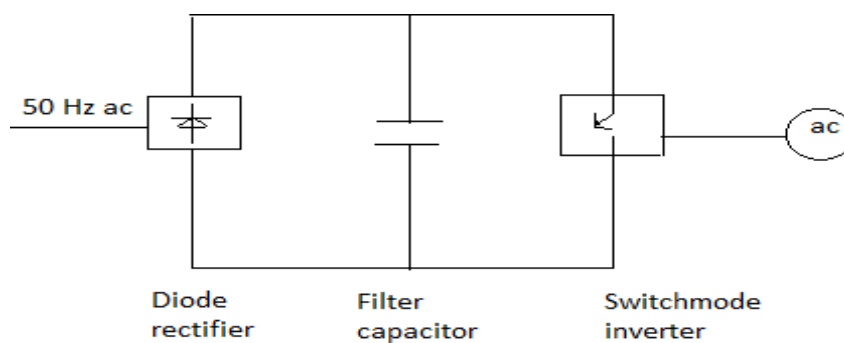

The VSI can be further divided into general 3 categories:

1. Pulse width modulated inverters
2. Square wave inverters
3. Single phase inverter with voltage cancellation

Pulse width modulated inverters

The input dc voltage is of constant magnitude . The diode rectifier is used to rectify the line voltage. The inverter control the magnitude and frequency of the ac output voltage.

This is achieved by PWM technique of inverter switches and this is called PWM inverters.

The sinusoidal PWM technique is one of the PWM technique to shape the output voltage to as close as sinusoidal output.

Basic concepts of switch mode inverter

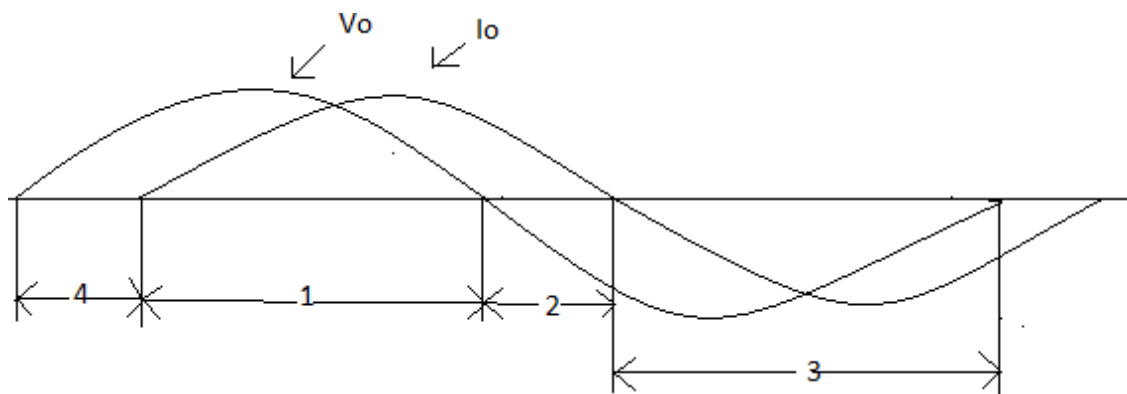
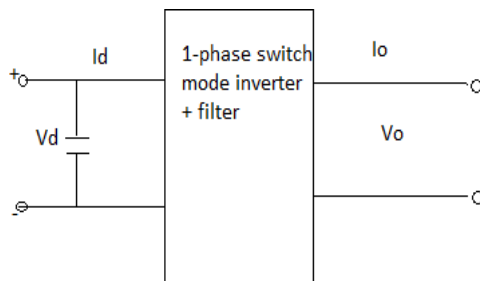

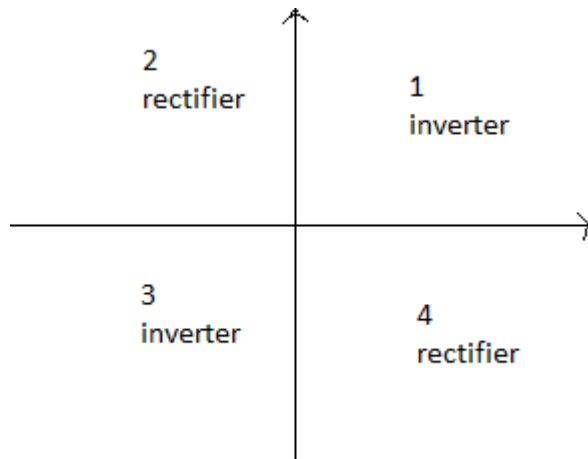

During interval 1 v_0 and i_0 both are positive

During interval 3 v_0 and i_0 both are negative

Therefore during 1 and 3 the instantaneous power flow is from dc side to corresponding to inverter mode of operation.

In contrast during interval 2 and 4 v_0 and i_0 are of opposite sign i.e. power flows from ac side to dc side corresponding to rectifier mode of operation.

Pulse width modulated switching scheme

We require the inverter output to be sinusoidal with magnitude and frequency controllable.

In order to produce sinusoidal output voltage at desired frequency a sinusoidal control signal at desired frequency is compared with a triangular waveform as show.

The frequency of the triangular waveform established the inverter switching frequency.

The triangular waveform is called carrier waveform. The triangular waveform establishes switching frequency f , which establishes with which the inverter switches are applied.

The control signal has frequency f_s and is used to modulate the switch duty ratio.

f_1 is the desired fundamental frequency of the output voltage.

The amplitude modulation ratio m_a is defined as

$$m_a = \frac{V_{control}}{V_{tri}}$$

$V_{control}$ is the peak amplitude of control signal.

V_{tri} peak amplitude of triangular signal.

The frequency modulation ratio m_f

$$m_f = \frac{f_s}{f_1}$$

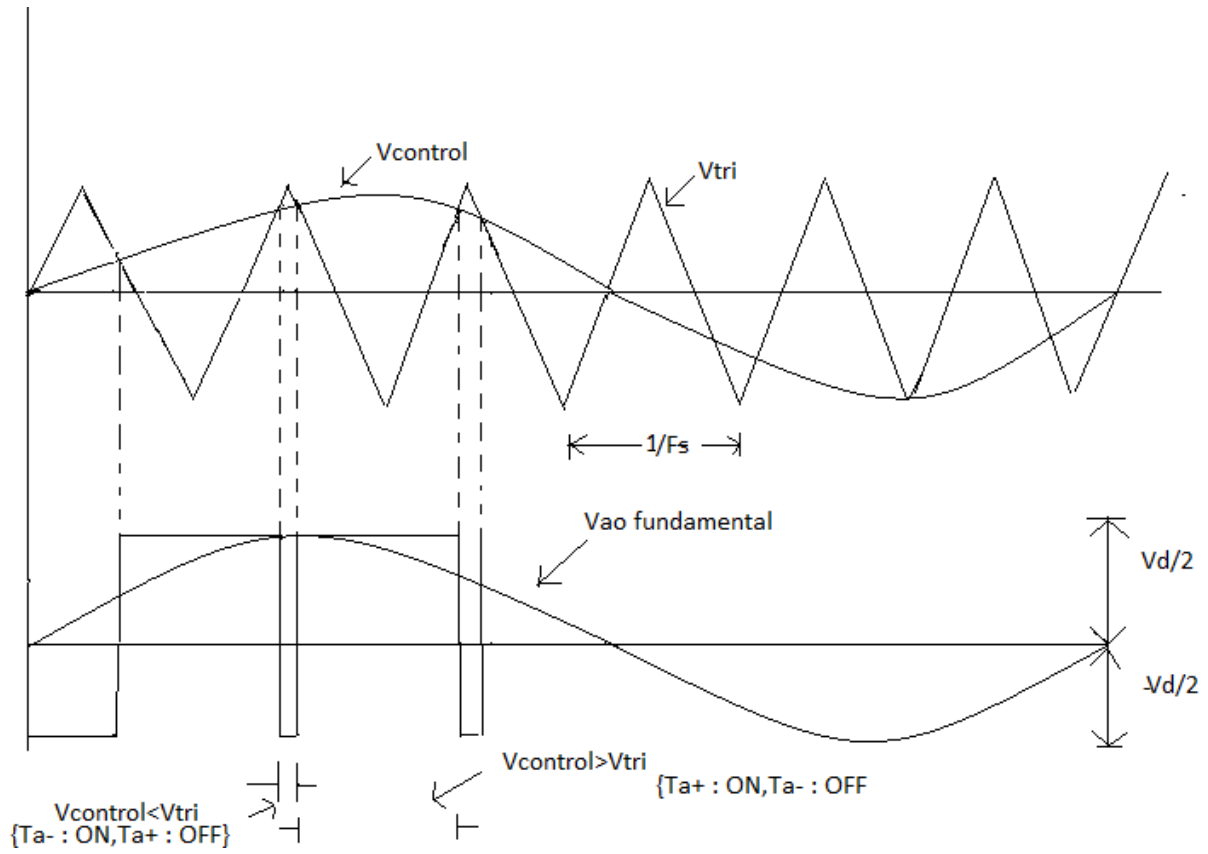

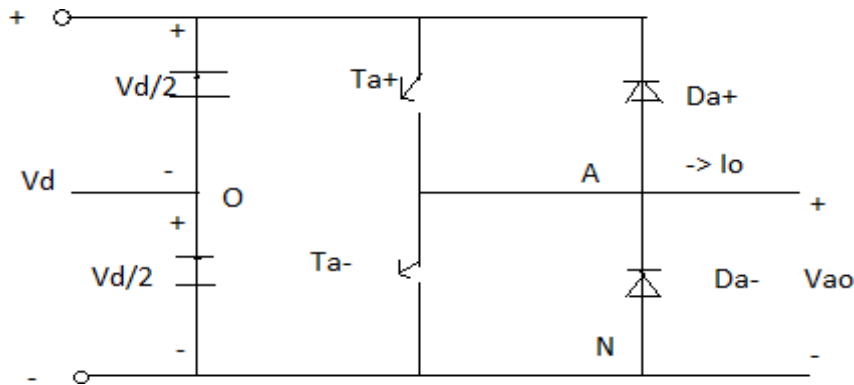

When $V_{control} > V_{tri}$ T^+ is ON $V_A = \frac{1}{2} V_d$

$V_{control} < V_{tri}$ T^- is ON $V_{AO} = \frac{1}{2} V_d$

So the following inferences can be drawn

The peak amplitude of fundamental frequency is m_a times $\frac{1}{2} V_d$

$$V_{AO} = m_a \frac{V_d}{2}$$

$$V_{AO} = \frac{V_{control}}{\hat{V}_{tri}} * \frac{V_d}{2} \quad V_{control} \leq \hat{V}_{tri}$$

The foregoing arguments shown why $V_{control}$ is chosen to be sinusoidal to provide sinusoidal output voltage with fewer harmonics

Let the $V_{control}$ vary sinusoidal with frequency f_1 , which is the desired frequency of the inverter output voltage.

$$\text{Let } V_{control} = \hat{V}_{control} \sin \omega_1 t$$

$$\hat{V}_{control} \leq \hat{V}_{tri}$$

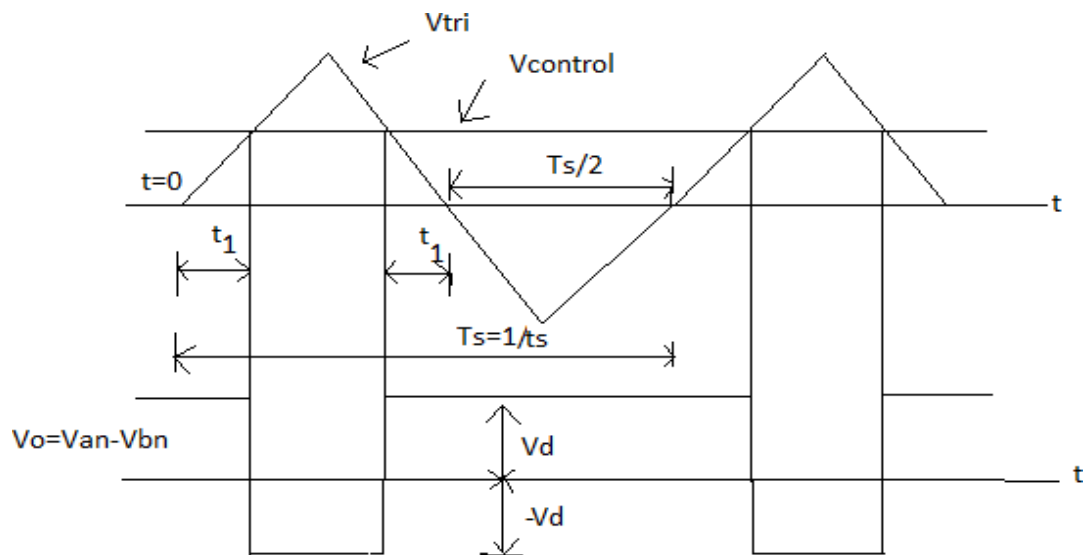

$$\hat{v}_{tri} = \frac{\hat{V}_{tri}}{T_s/4}$$

At $t = t_1$, $v_{tri} = v_{control}$

$$\text{So } \frac{v_{control}}{t_1} = \frac{\hat{V}_{tri}}{T_s/4}$$

$$t_1 = \frac{\hat{v}_{control} * T_s}{\hat{V}_{tri} * 4}$$

$$T_{on} = 2t_1 + \frac{T_s}{2}$$

$$D_1 = \frac{T_{on}}{T_s} = \frac{2t_1 + \frac{T_s}{2}}{T_s}$$

$$= \frac{1}{2} + \frac{2t_1}{T_s}$$

$$D_1 = \frac{1}{2} + \left(\frac{\hat{v}_{control}}{\hat{V}_{tri}} \right)$$

Three phase inverter

When three single-phase inverters are connected in parallel a three phase inverter is formed.

The gating signal has to be displaced by 120° with respect to each other so as achieve three phase balanced voltages.

A 3-phase output can be achieved from a configuration of six transistors and six diodes.

Two type of control signal can be applied to transistors, they are such as 180° or 120° conduction.

180-degree conduction

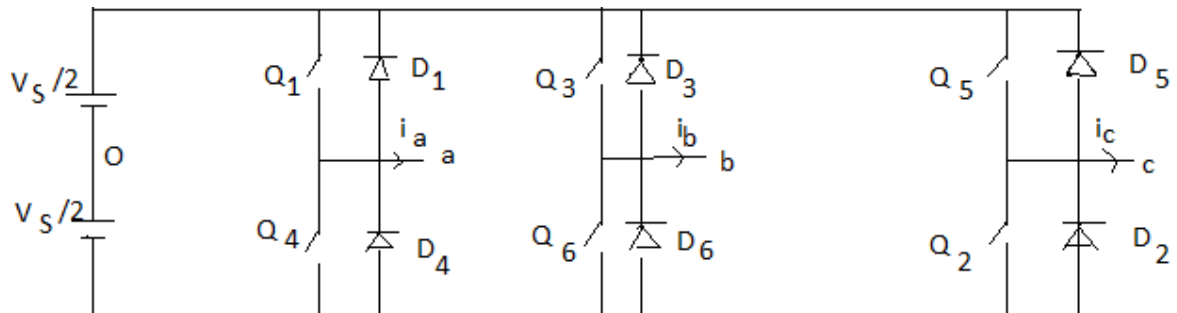

When Q_1 is switched on, terminal a is connected to the positive terminal of dc input voltage.

When Q_4 is switched on terminal a is brought to negative terminal of the dc source.

There are 6 modes of operation in a cycle and the duration of each mode is 60° .

The conduction sequence of transistors is 123,234,345,456,561,612. The gating signals are shifted from each other by 60° to get 3- ϕ balanced voltages.

Switching states for the three phase voltage inverters

Step I

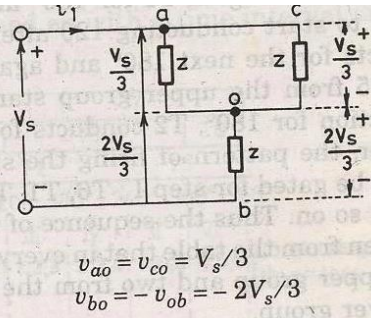
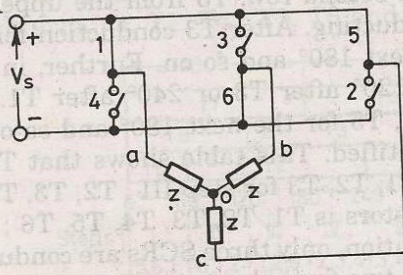

Step II

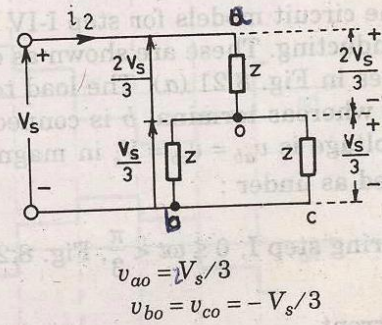
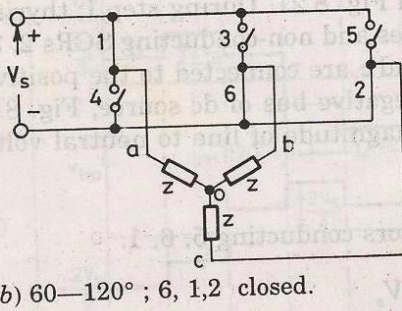

Step III

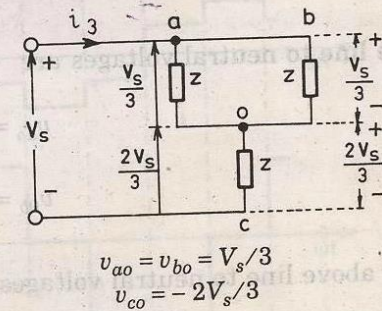
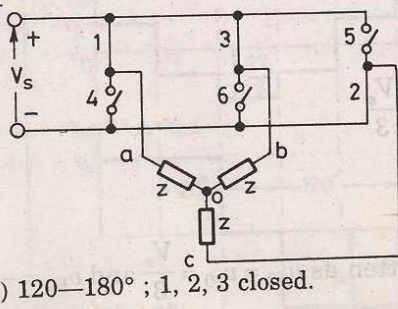

Step IV

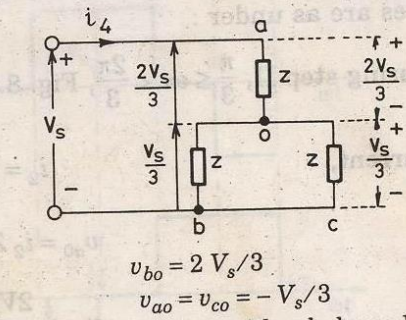
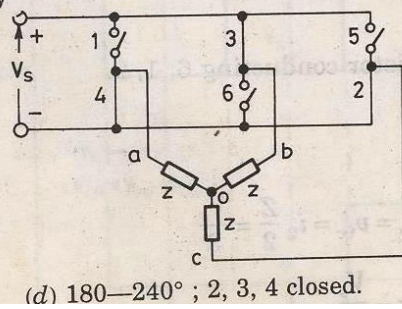

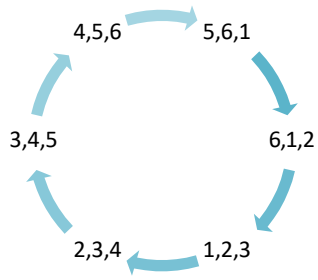

V_{RN}	V_{YN}	V_{BN}	V_{RY}	V_{YB}	V_{BR}	V_1
$\frac{V}{3}$	$-\frac{2V}{3}$	$\frac{V}{3}$	V_{ac}	$-V_{dc}$	0	$\frac{2}{\sqrt{3}}(330^\circ)$
$\frac{2V}{3}$	$-\frac{V}{3}$	$-\frac{V}{3}$	V_{dc}	0	$-V_{dc}$	$\frac{2}{\sqrt{3}}(30^\circ)$
$\frac{V}{3}$	$\frac{V}{3}$	$-\frac{2V}{3}$	0	V	-V	$\frac{2}{\sqrt{3}}(90^\circ)$
$-\frac{V}{3}$	$\frac{2V}{3}$	$-\frac{V}{3}$	-V	V	0	$\frac{2}{\sqrt{3}}(150^\circ)$
$-\frac{2V}{3}$	$\frac{V}{3}$	$\frac{V}{3}$	-V	0	0	$\frac{2}{\sqrt{3}}(210^\circ)$
$-\frac{V}{3}$	$-\frac{V}{3}$	$\frac{2V}{3}$	0	-V	0	$\frac{2}{\sqrt{3}}(270^\circ)$

Fourier analysis

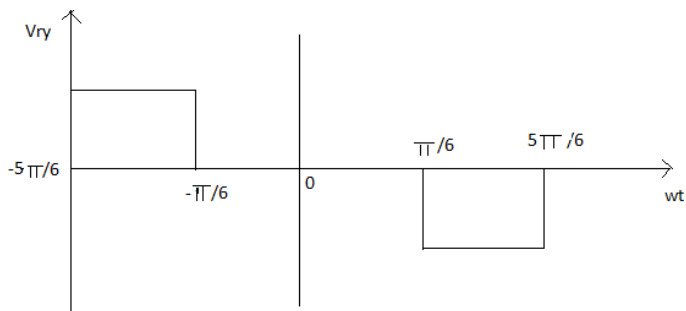

If we go for harmonic analysis $V_{RY} = \sum_{n=1,3,5,\dots}^{\infty} \frac{4V}{3} \sin \frac{n\pi}{6} \sin(\omega t + \frac{n\pi}{6})$

$$V_{YB} = \sum_{n=1,3,5,\dots}^{\infty} \frac{4V_S \sin \frac{n\pi}{3}}{n\pi} \sin(\omega t - \frac{\pi}{2})$$

$$V_{BR} = \sum_{n=1,3,5,\dots}^{\infty} \frac{4V_S \sin \frac{n\pi}{3}}{n\pi} \sin(\omega t - \frac{\pi}{6})$$

All even harmonics are zero all triple n harmonics are zero.

The rms nth component of the line voltage is

$$= \frac{4V_S}{\sqrt{2}n\pi} \sin \frac{n\pi}{3} = \frac{4V_S}{\sqrt{2}\pi} \sin(60^\circ)$$

For n=1

$$= 0.7797V_S$$

Three phase 120° mode VSI

The circuit diagram is same as that for 180° mode of conduction.

Here each thyristor conducts for 120°. There are 6 steps each of 60° duration, for completing one cycle of ac output voltage.

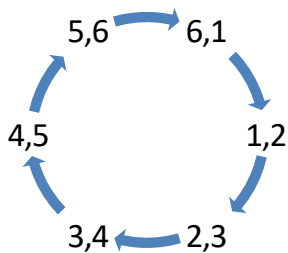

Step I

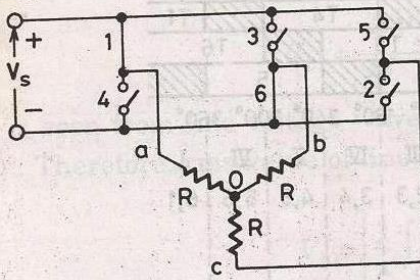

(a) $0-60^\circ$; 6, 1 closed

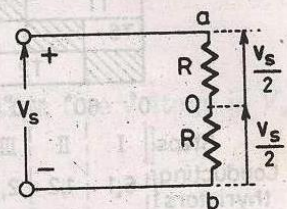

$$v_{ao} = V_s/2$$

$$v_{bo} = -V_s/2 \text{ and } v_{co} = 0$$

Step II

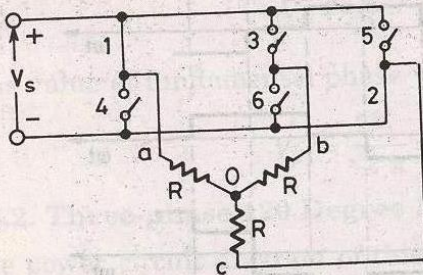

(b) $60-120^\circ$; 1, 2 closed

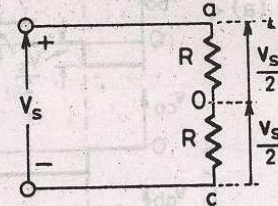

$$v_{ao} = V_s/2$$

$$v_{co} = -V_s/2 \text{ and } v_{bo} = 0$$

Step III

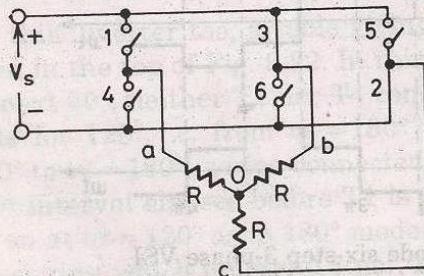

(c) $120-180^\circ$; 2, 3 closed

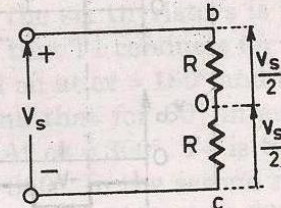

$$v_{bo} = V_s/2$$

$$v_{co} = -V_s/2 \text{ and } v_{ao} = 0$$

Step IV

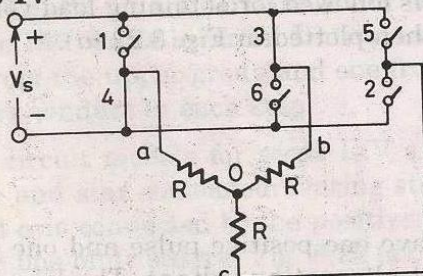

(d) $180-240^\circ$; 3, 4 closed

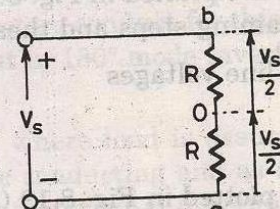

$$v_{bo} = V_s/2$$

$$v_{ao} = -V_s/2 \text{ and } v_{co} = 0$$

Step 1: 6,1 conducting

$$V_{an} = \frac{V}{2}, V_{yn} = \frac{-V_s}{2}, V_{cn} = 0$$

Step 2: 1,2 conducting

$$V_{an} = \frac{V_s}{2}, V_{bn} = 0, V_{cn} = \frac{-V_s}{2}$$

Step 3: 2,3 conducting

$$V_{an} = 0, V_{bn} = \frac{V_s}{2}, V_{cn} = \frac{-V_s}{2}$$

Step 4: 3,4 conducting

$$V_{an} = \frac{-V_s}{2}, V_{bn} = \frac{V_s}{2}, V_{cn} = 0$$

Step 5: 4,5 conducting

$$V_{an} = \frac{-V_s}{2}, V_{bn} = 0, V_{cn} = \frac{V_s}{2}$$

Step 6: 5,6 conducting

$$V_{an} = 0, V_{bn} = \frac{-V_s}{2}, V_{cn} = \frac{V_s}{2}$$

120° conduction mode

Step	Thyristor conducting	V_{Rn}	V_{Yn}	V_{Bn}	\rightarrow v
1	6,1	$V_s/2$	$-V_s/2$	0	$\frac{\sqrt{3}V_s}{2} (-30^\circ)$
2	1,2	$V_s/2$	0	$-V_s/2$	$\frac{\sqrt{3}V_s}{2} (30^\circ)$
3	2,3	0	$V_s/2$	$-V_s/2$	$\frac{\sqrt{3}V_s}{2} (90^\circ)$
4	3,4	$-V_s/2$	$V_s/2$	0	$\frac{\sqrt{3}V_s}{2} (150^\circ)$
5	4,5	$-V_s/2$	0	$V_s/2$	$\frac{\sqrt{3}V_s}{2} (210^\circ)$
6	5,6	0	$-V_s/2$	$V_s/2$	$\frac{\sqrt{3}V_s}{2} (-30^\circ)$

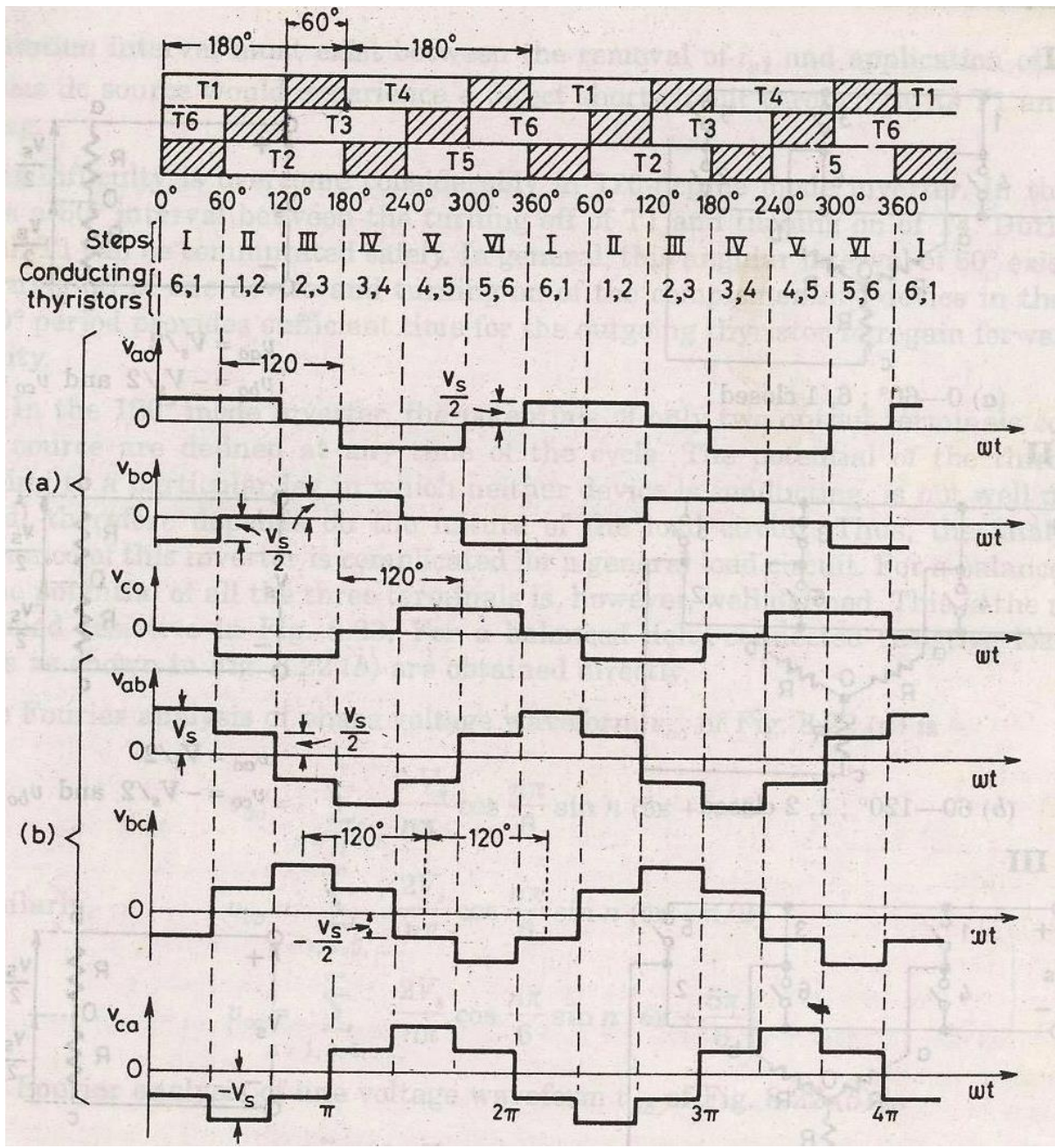

Introduction to Programmable Logic Controllers (PLC's)

Industrial Control Systems
Fall 2006

The Need for PLCs

- Hardwired panels were very time consuming to wire, debug and change.
- GM identified the following requirements for computer controllers to replace hardwired panels.
 - Solid-state not mechanical
 - Easy to modify input and output devices
 - Easily programmed and maintained by plant electricians
 - Be able to function in an industrial environment

The First Programmable Logic Controllers (PLCs)

- Introduced in the late 1960's
- Developed to offer the same functionality as the existing relay logic systems
- Programmable, reusable and reliable
 - Could withstand a harsh industrial environment
 - They had no hard drive, they had battery backup
 - Could start in seconds
 - Used Ladder Logic for programming

Programmable Logic Controller

- A programmable logic controller (PLC) is a specialized computer used to control machines and process.
- It uses a programmable memory to store instructions and specific functions that include On/Off control, timing, counting, sequencing, arithmetic, and data handling

Advantages of PLC Control Systems

- Flexible
- Faster response time
- Less and simpler wiring
- Solid-state - no moving parts
- Modular design - easy to repair and expand
- Handles much more complicated systems
- Sophisticated instruction sets available
- Allows for diagnostics “easy to troubleshoot”
- Less expensive

Advantages of a PLC Control System

Eliminates much of the hard wiring that was associated with conventional relay control circuits.

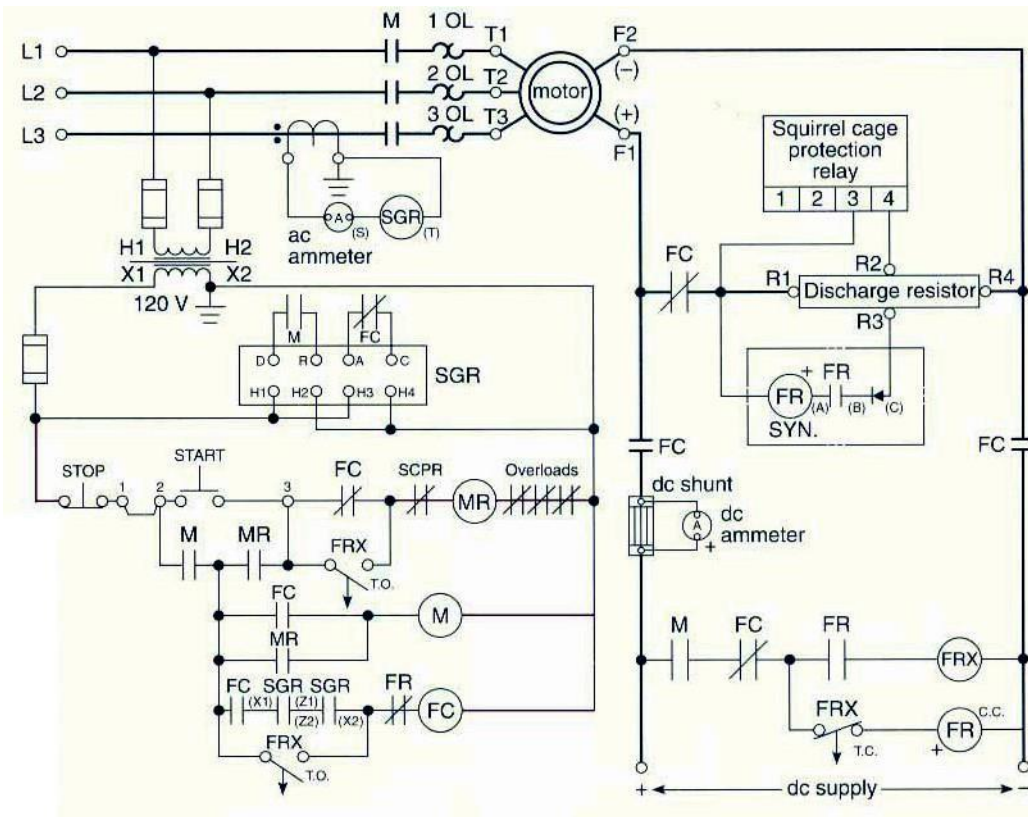

The program takes the place of much of the external wiring that would be required for control of a process.

Advantages of a PLC Control System

Increased Reliability:

Once a program has been written and tested it can be downloaded to other PLCs.

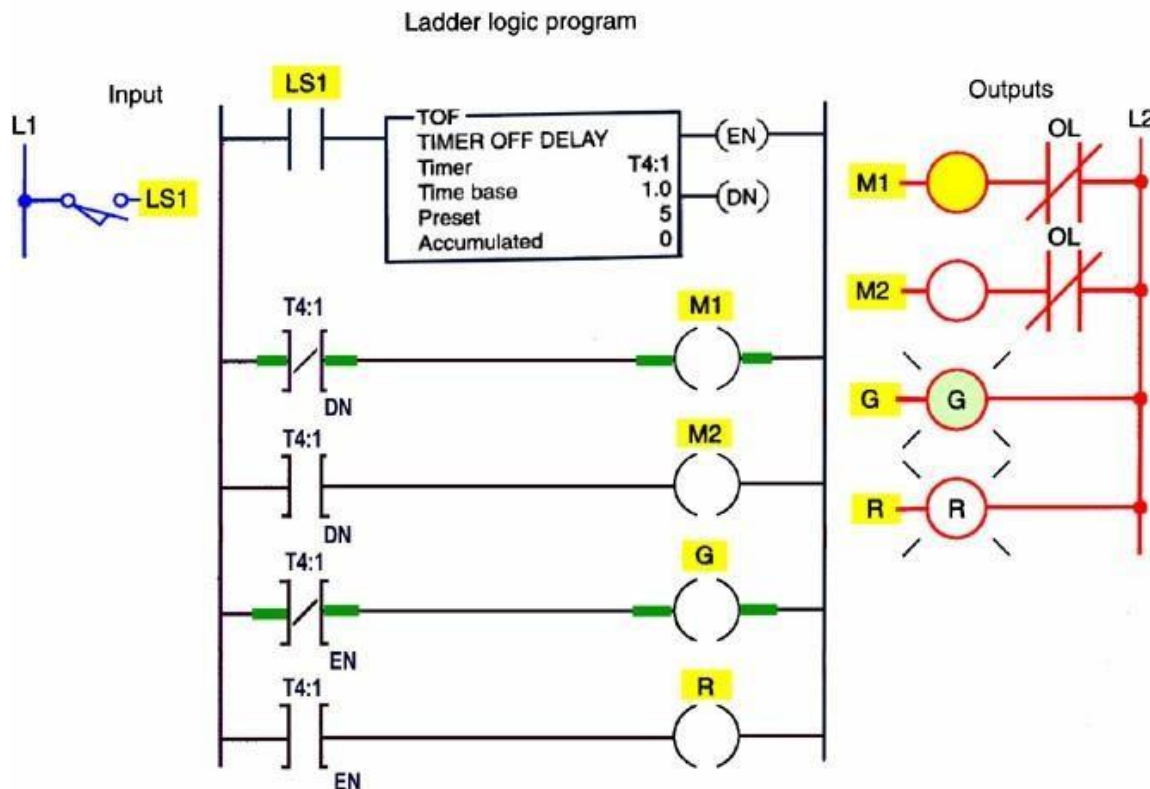

Since all the logic is contained in the PLC's memory, there is no chance of making a logic wiring error.

Conversely

Advantages of a PLC Control System

More Flexibility:

Original equipment manufacturers (OEMs) can provide system updates for a process by simply sending out a new program.

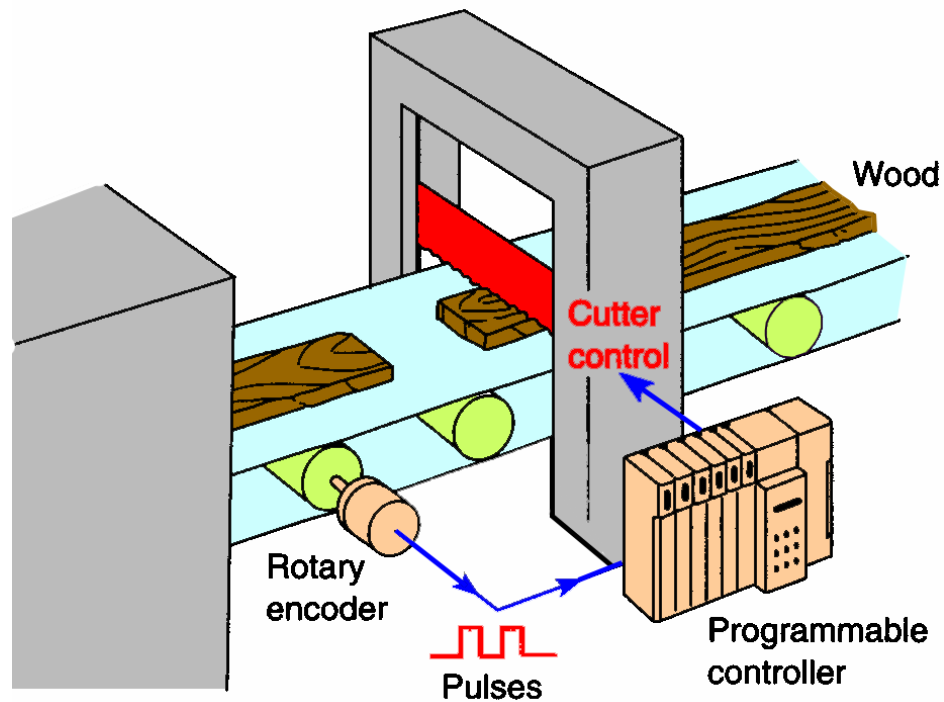

It is easier to create and change a program in a PLC than to wire and rewire a circuit. End-users can modify the program in the field.

Advantages of a PLC Control System

Lower Costs:

Originally PLCs were designed to replace relay control logic. The cost savings using PLCs have been so significant that relay control is becoming obsolete, except for power applications.

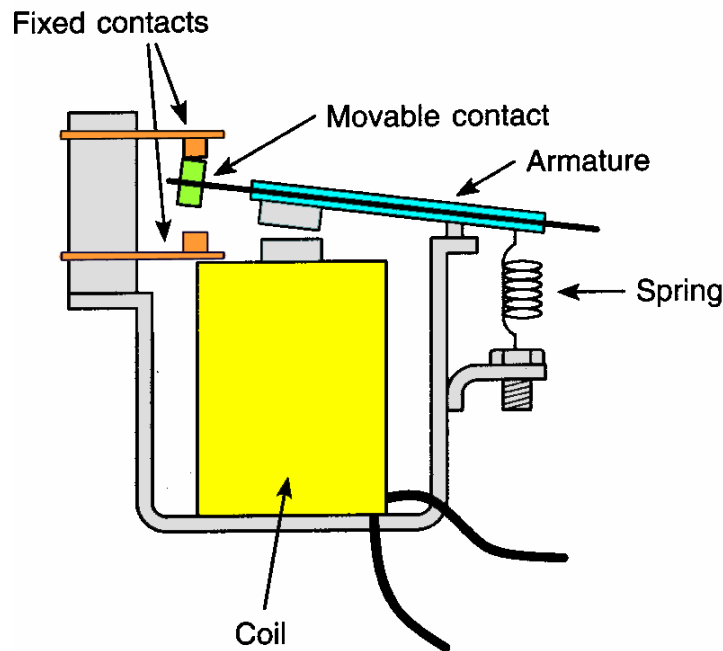

Generally, if an application requires more than about 6 control relays, it will usually be less expensive to install a PLC.

Advantages of a PLC Control System

Communications Capability:

A PLC can communicate with other controllers or computer equipment.

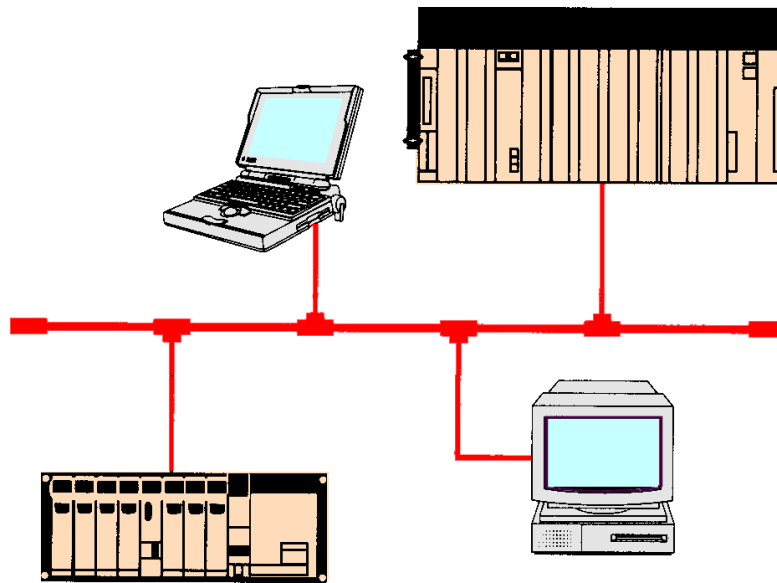

They can be networked to perform such functions as: supervisory control, data gathering, monitoring devices and process parameters, and downloading and uploading of programs.

Advantages of a PLC Control System

Faster Response Time:

PLCs operate in real-time which means that an event taking place in the field will result in an operation or output taking place.

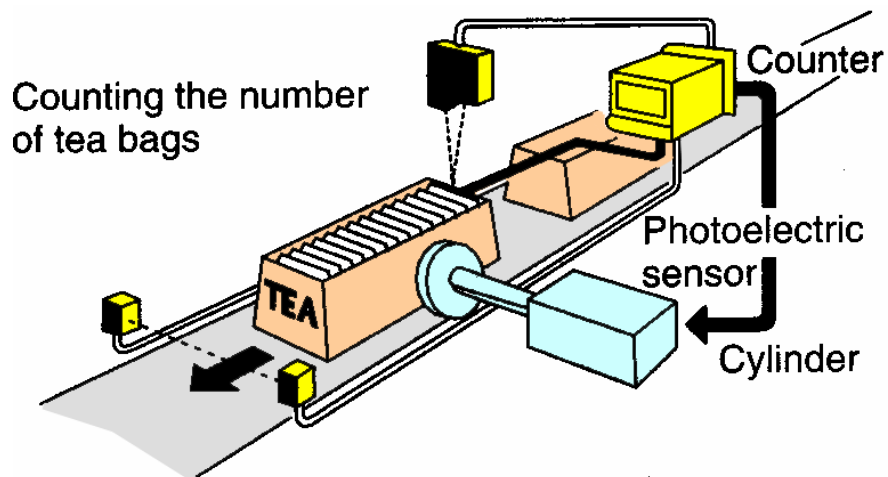

Machines that process thousands of items per second and objects that spend only a fraction of a second in front of a sensor require the PLC's quick response capability.

Advantages of a PLC Control System

Easier To Troubleshoot:

PLCs have resident diagnostic and override functions allowing users to easily trace and correct software and hardware problems.

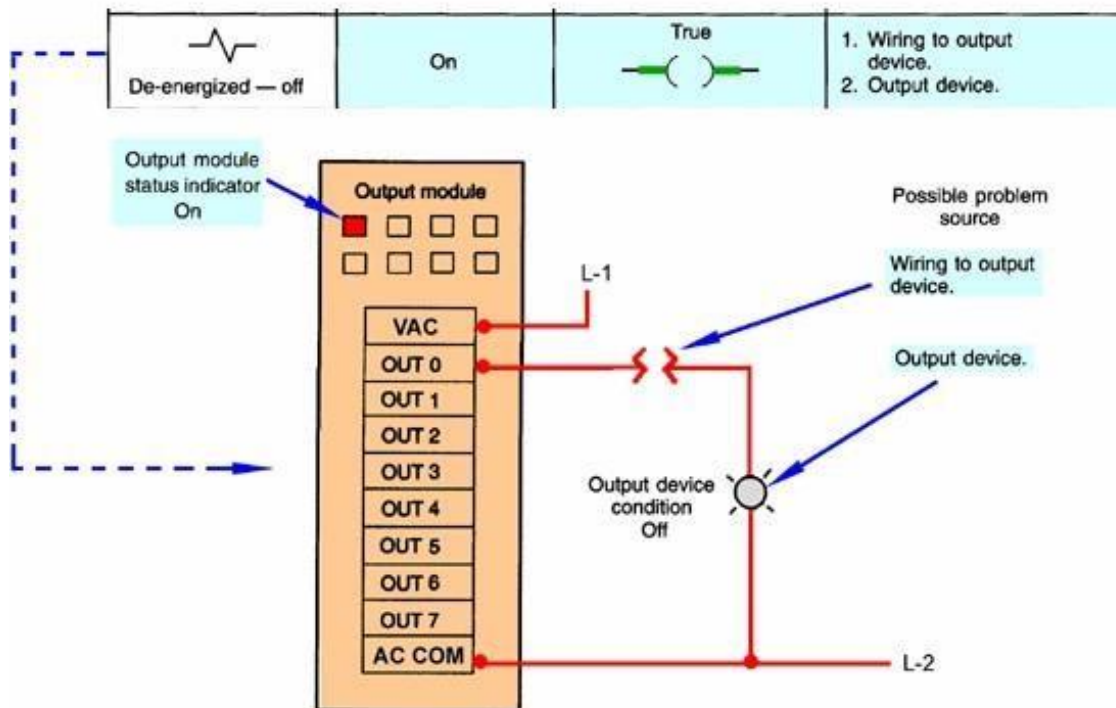

The control program can be watched in real-time as it executes to find and fix problems

PLC Architecture

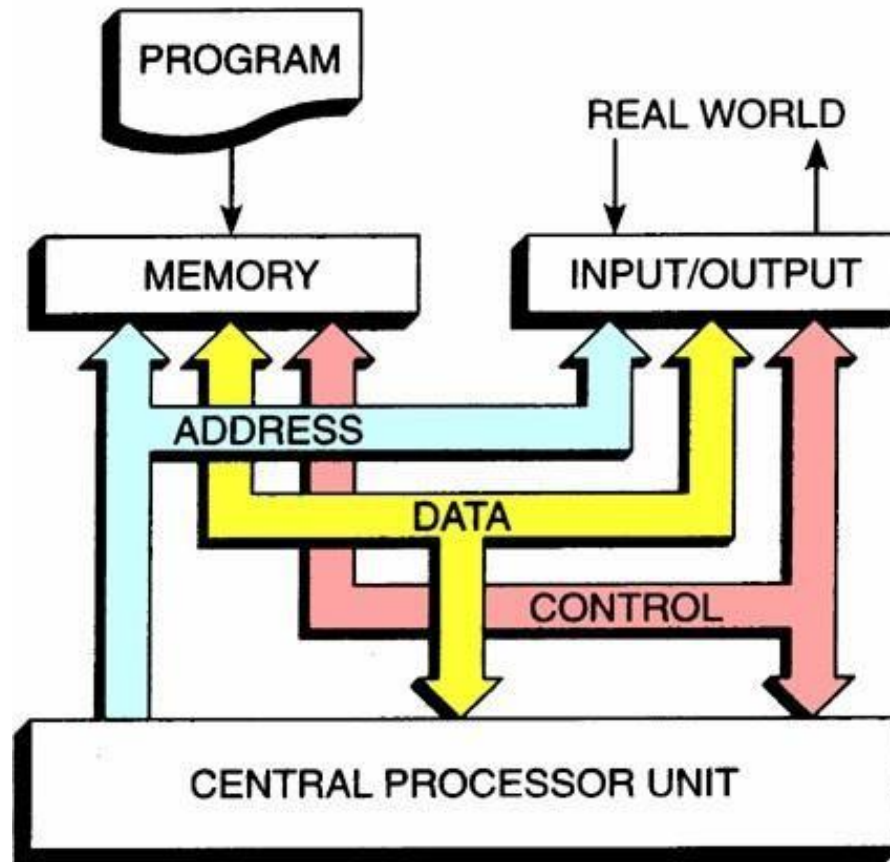

The structure of a PLC is based on the same principles as those employed in computer architecture.

PLC System

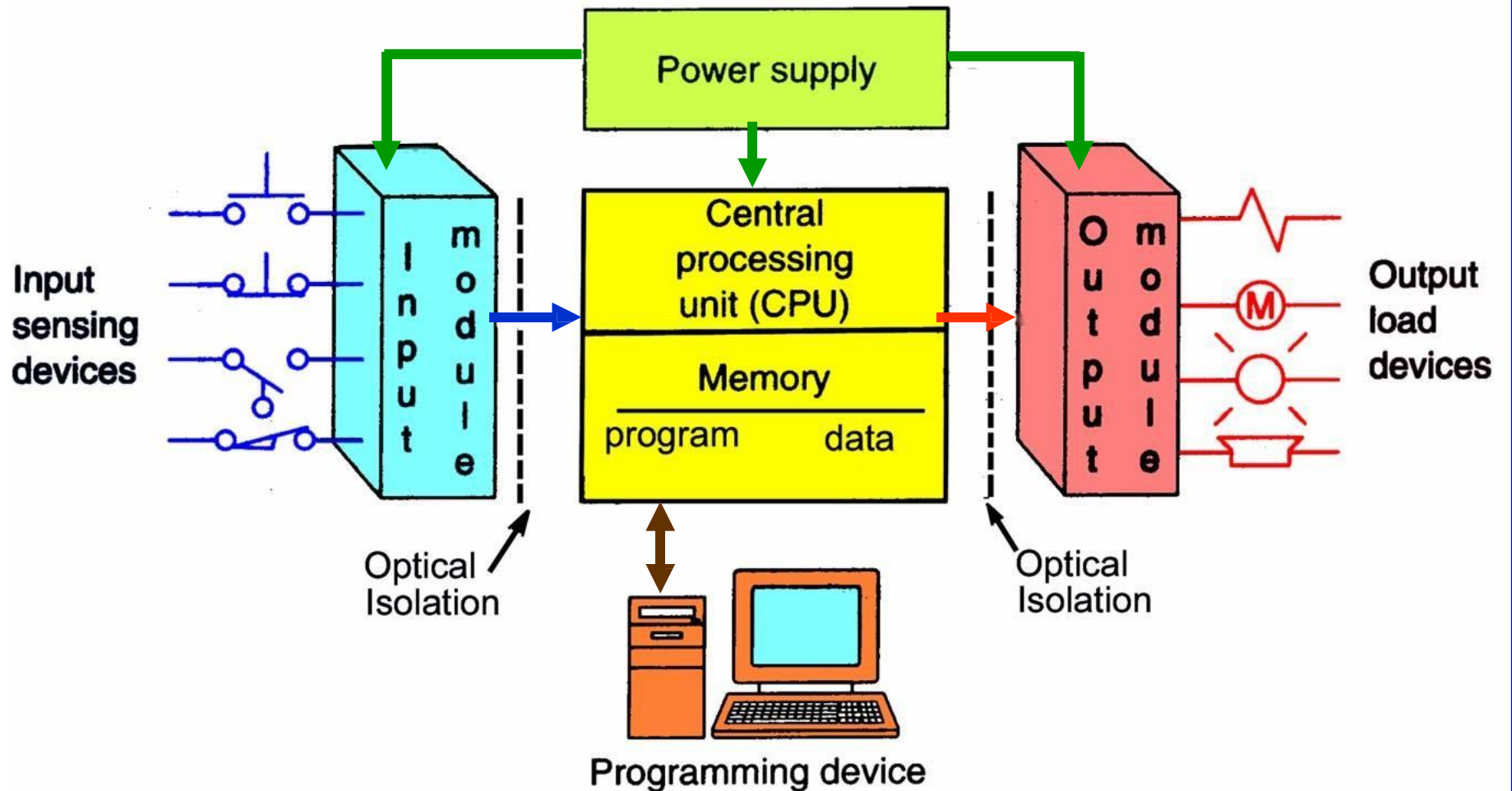

PLC Architecture

- An *open architecture* design allows the system to be connected easily to devices and programs made by other manufacturers.
- A *closed architecture* or *proprietary* system, is one whose design makes it more difficult to connect devices and programs made by other manufacturers.

NOTE: When working with PLC systems that are proprietary in nature you must be sure that any generic hardware or software you use is compatible with your particular PLC.

I/O Configurations

Fixed I/O

- Is typical of small PLCs
- Comes in one package, with no separate removable units.
- The processor and I/O are packaged together.
- Lower in cost – but lacks flexibility.

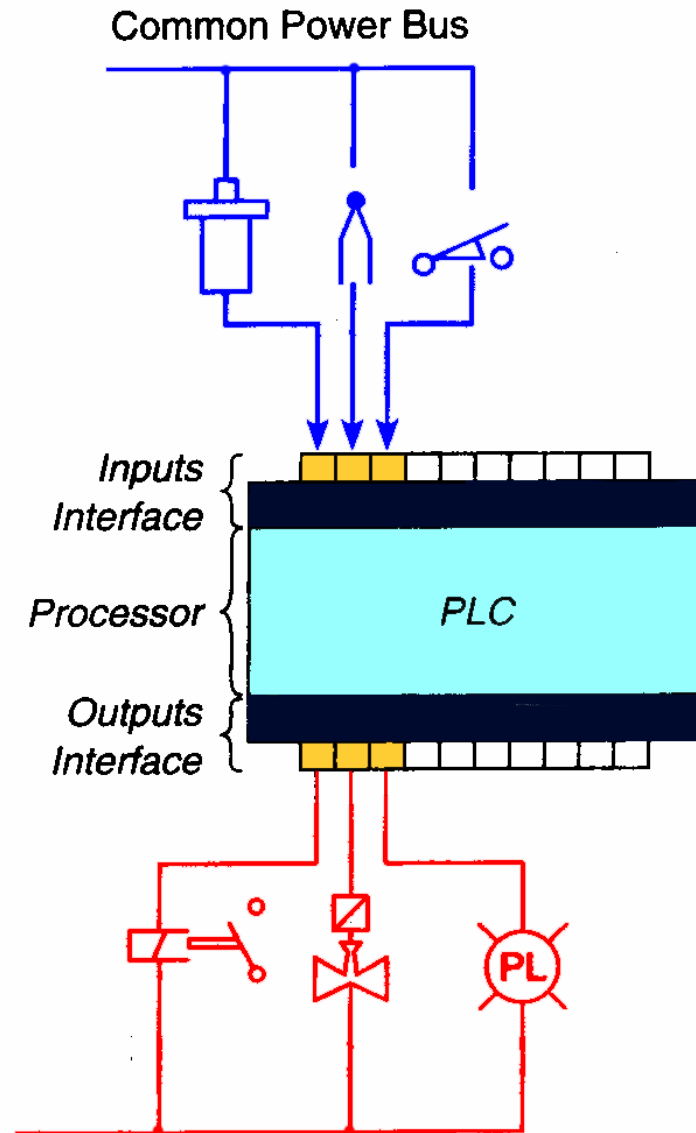

I/O Configurations

Modular I/O

Is divided by compartments into which separate modules can be plugged.

This feature greatly increases your options and the unit's flexibility. You can choose from all the modules available and mix them in any way you desire.

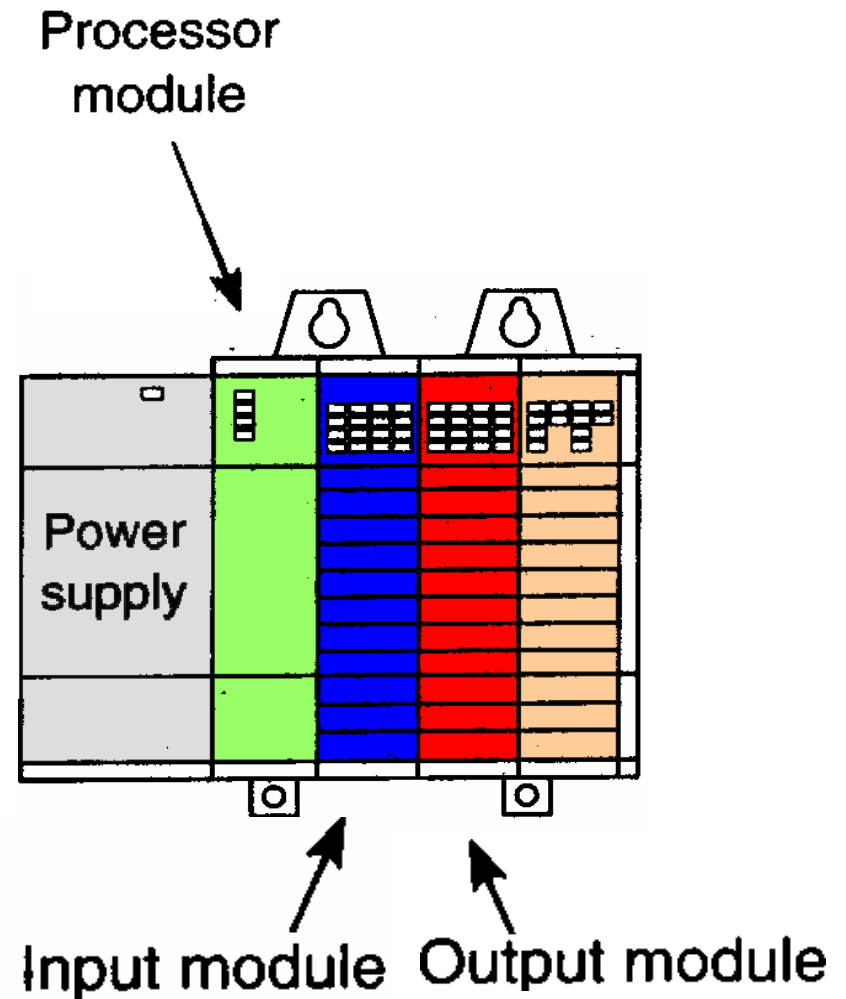

I/O Configurations

Modular I/O

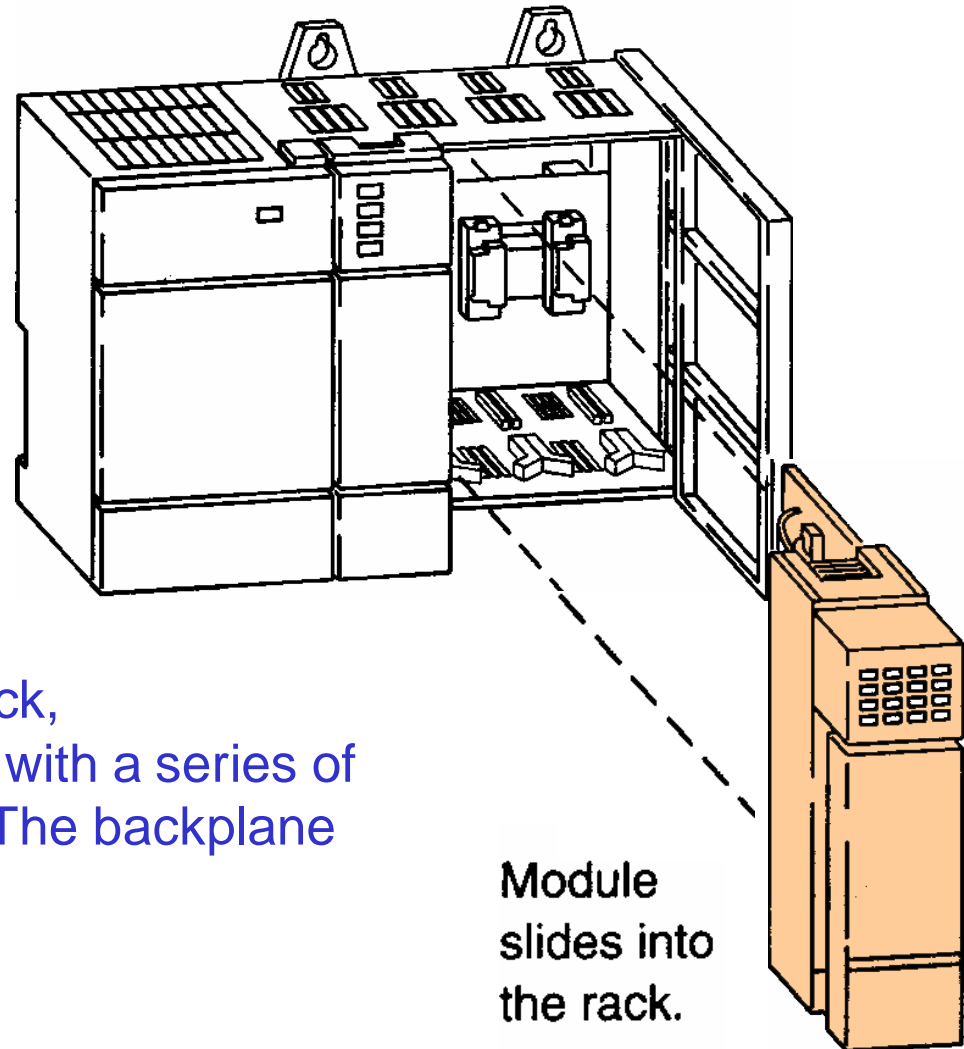

When a module slides into the rack, it makes an electrical connection with a series of contacts - called the *backplane*. The backplane is located at the rear of the rack.

Module slides into the rack.

Power Supply

- Supplies DC power to other modules that plug into the rack.
- In large PLC systems, this power supply does not normally supply power to the field devices.
- In small and micro PLC systems, the power supply is also used to power field devices.

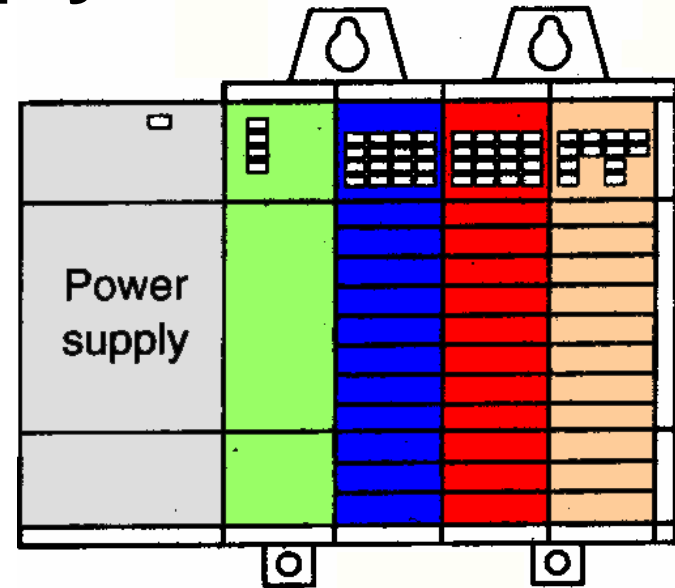

Processor (CPU)

- Is the “brain” of the PLC.
- Consists of a microprocessor for implementing the logic, and controlling the communications among the modules.
- Designed so the desired circuit can be entered in relay ladder logic form.
- The processor accepts input data from various sensing devices, executes the stored user program, and sends appropriate output commands to control devices.

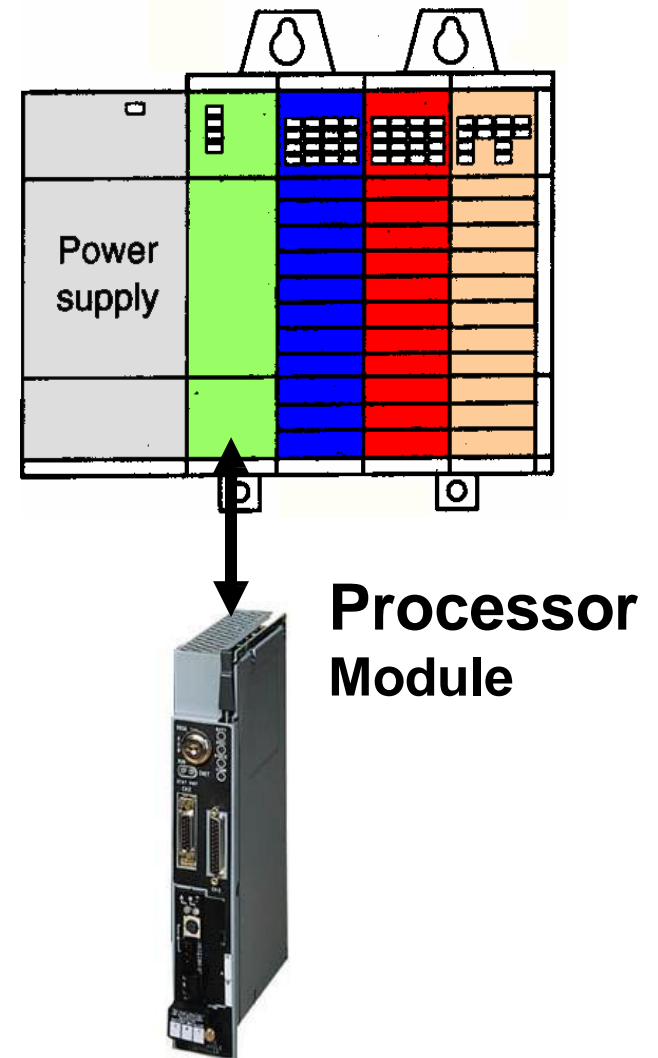

I/O Section

Consists of:

- Input modules
- Output modules.

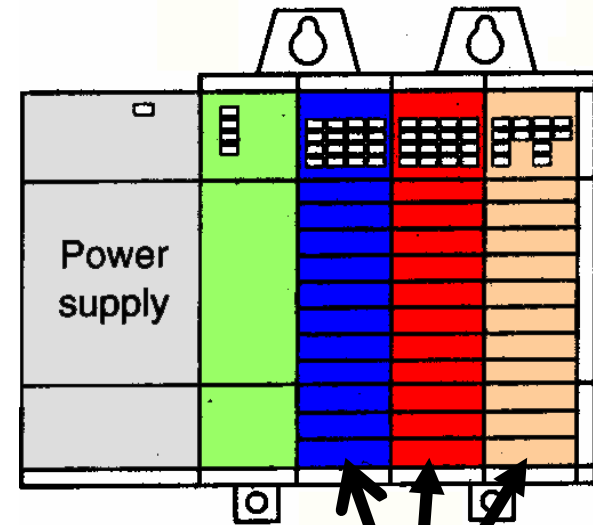

I/O Section

Input Module

- Forms the interface by which input field devices are connected to the controller.
- The terms “field” and “real world” are used to distinguish actual external devices that exist and must be physically wired into the system.

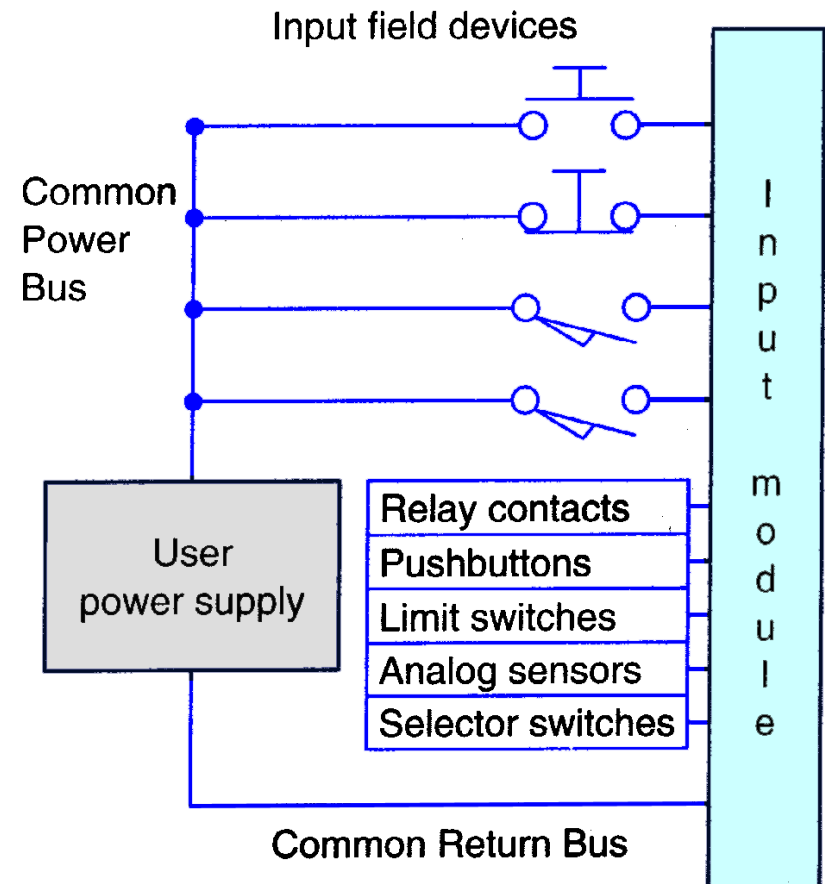

I/O Section

Output Module

- Forms the interface by which output field devices are connected to the controller.
- PLCs employ an optical isolator which uses light to electrically isolate the internal components from the input and output terminals.

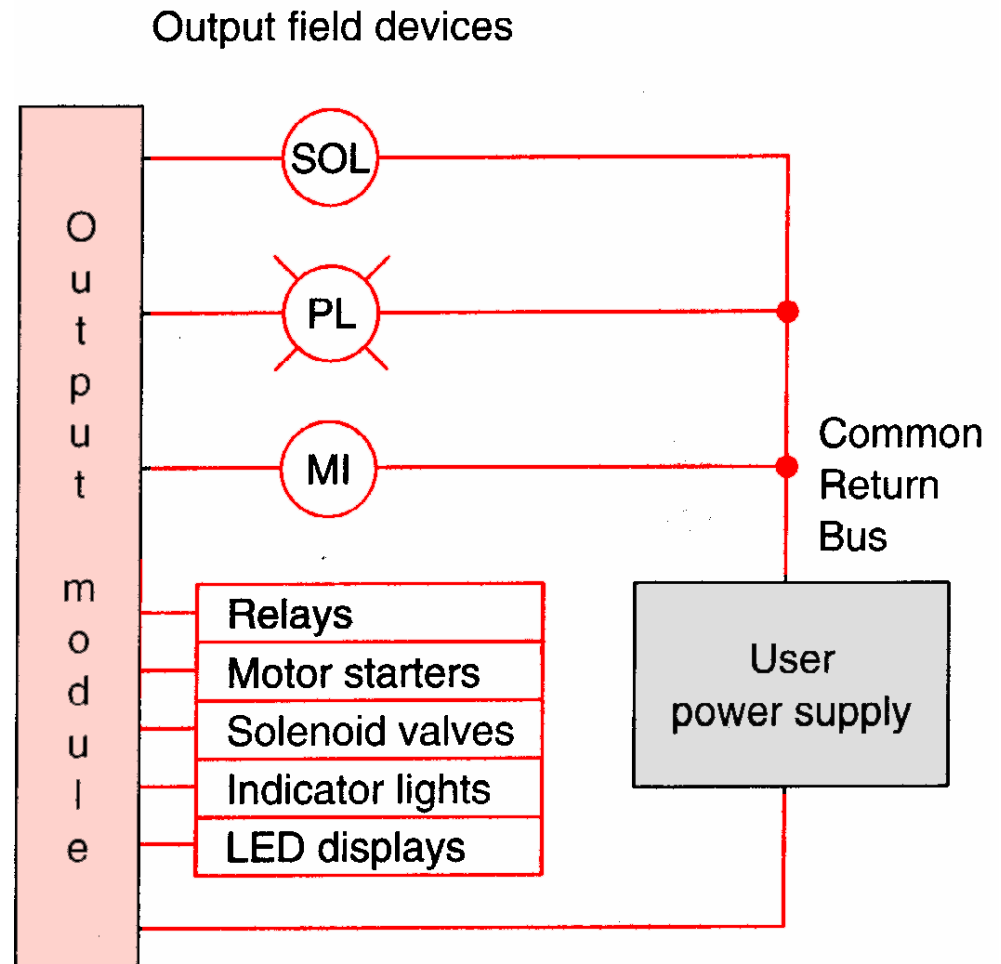

Programming Device

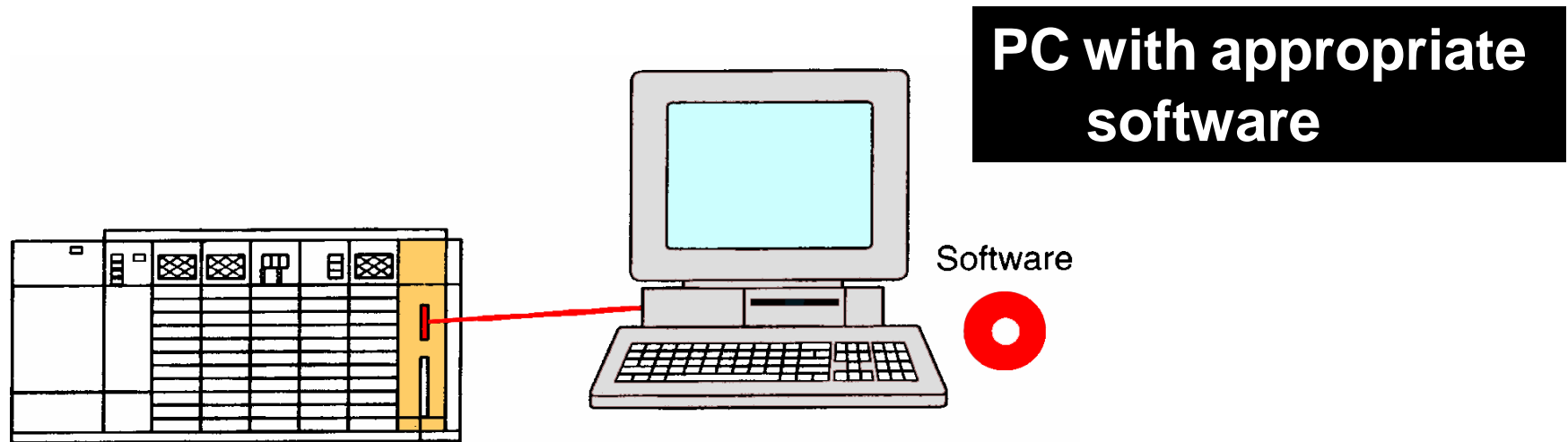

- A personal computer (PC) is the most commonly used programming device
- The software allows users to create, edit, document, store and troubleshoot programs
- The personal computer communicates with the PLC processor via a serial or parallel data communications link

Programming Device

**Hand-held unit
with display**

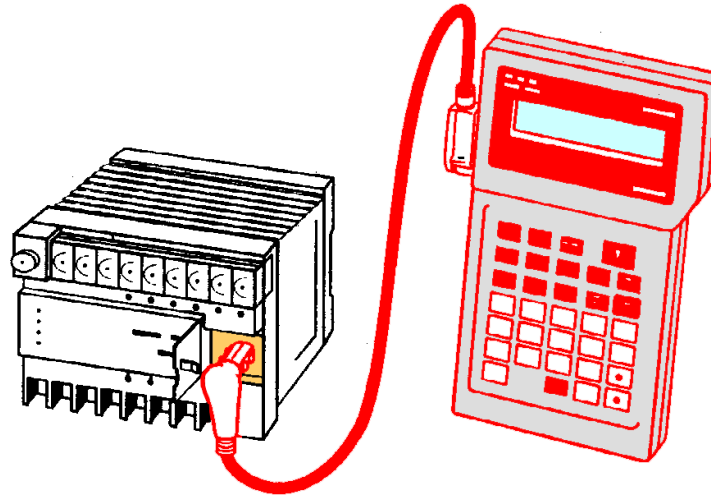

- Hand-held programming devices are sometimes used to program small PLCs
- They are compact, inexpensive, and easy to use, but are not able to display as much logic on screen as a computer monitor

Programming Device

**Hand-held unit
with display**

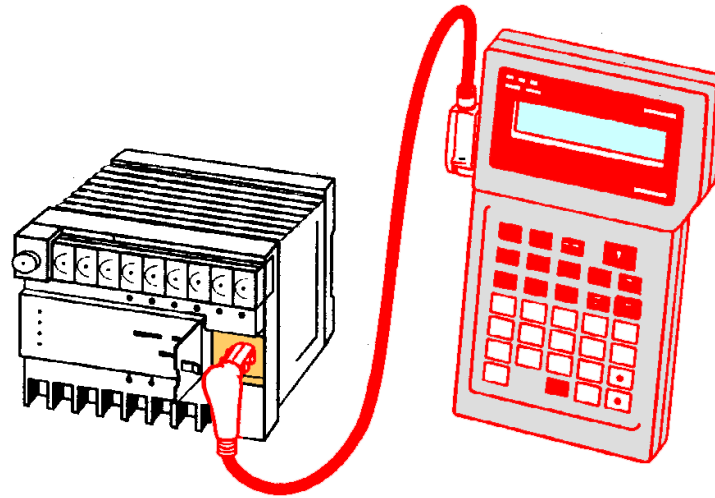

- Hand-held units are often used on the factory floor for troubleshooting, modifying programs, and transferring programs to multiple machines.

PLC Mixer Process Control Problem

Mixer motor to automatically stir the liquid in the vat when the temperature and pressure reach preset values

Alternate manual pushbutton control of the motor to be provided

The temperature and pressure sensor switches close their respective contacts when conditions reach their preset values

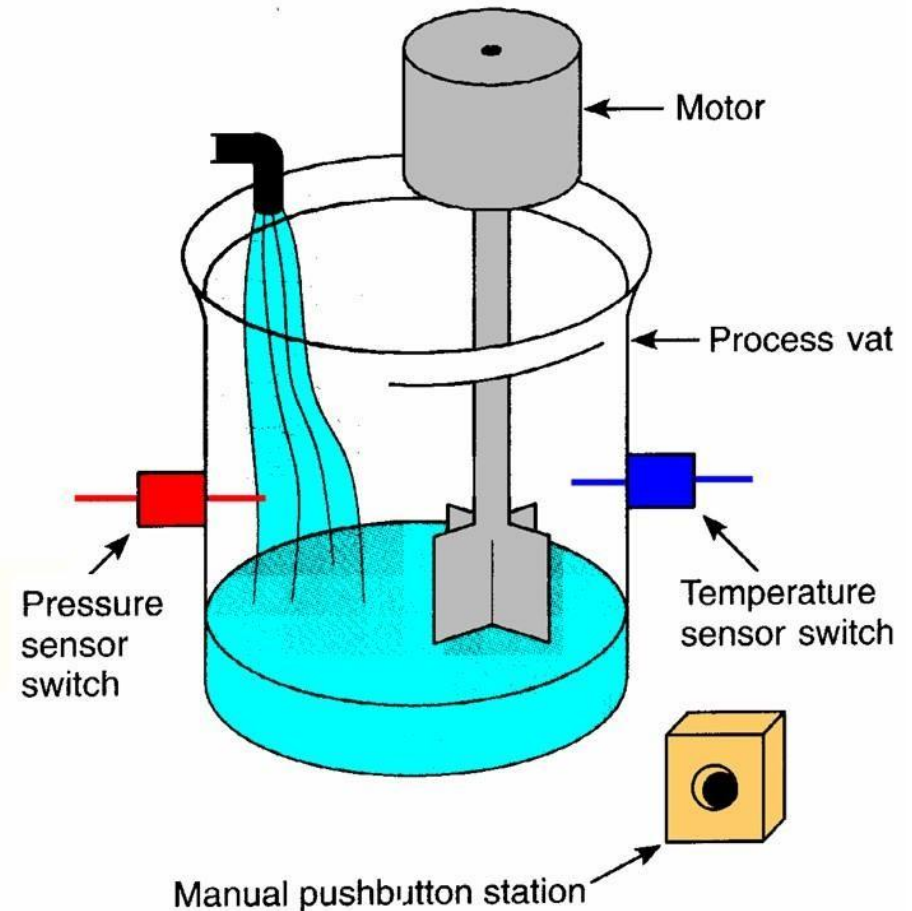

Process Control Relay Ladder Diagram

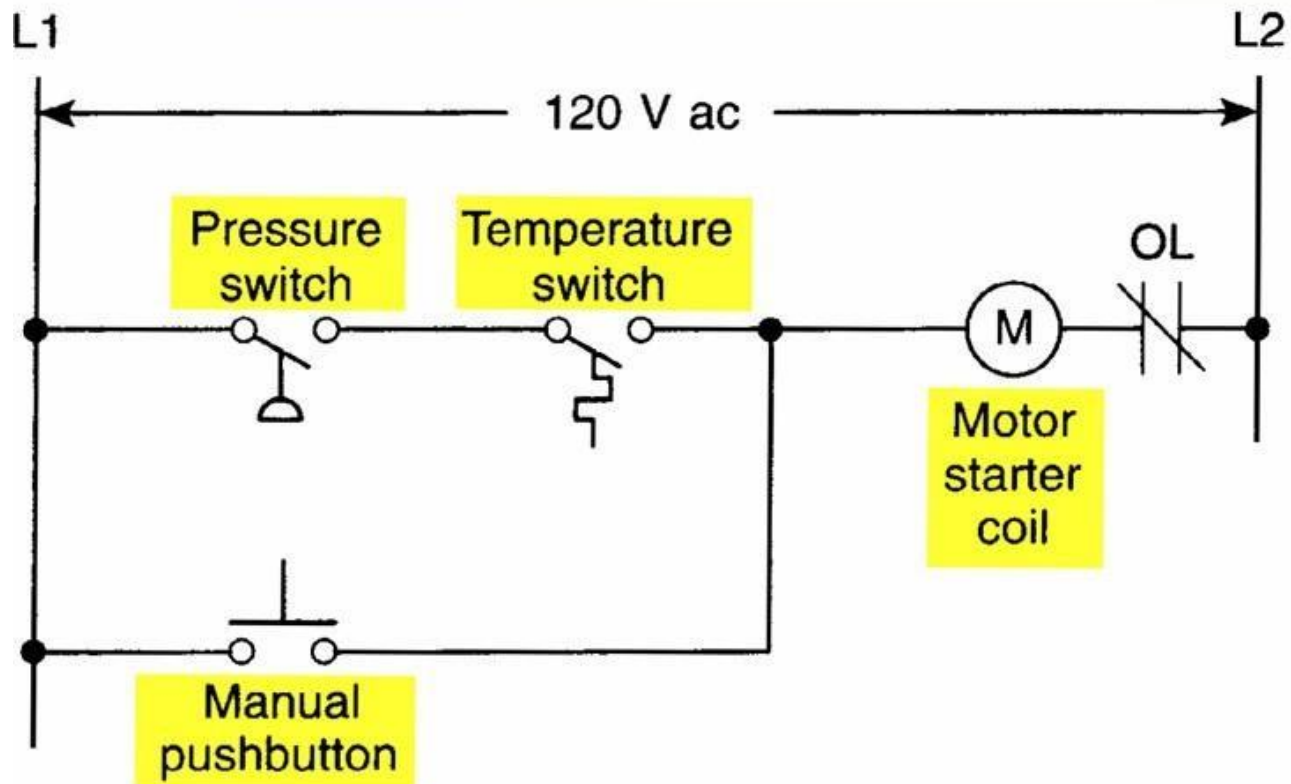

Motor starter coil is energized when both the pressure and temperature switches are closed or when the manual pushbutton is pressed

PLC Input Module Connections

- The same input field devices are used
- These devices are wired to the input module according to the manufacturer's labeling scheme

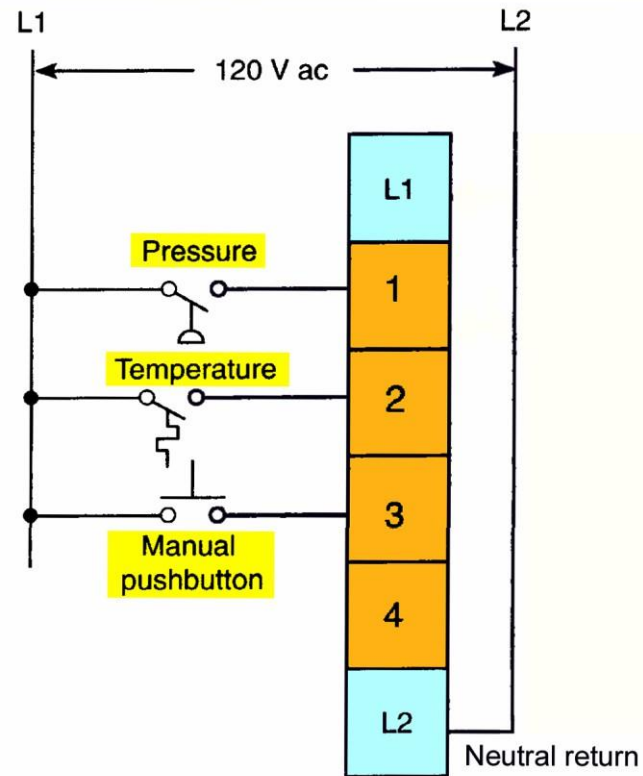

PLC Output Module Connections

Same output field device is used and wired to the output module

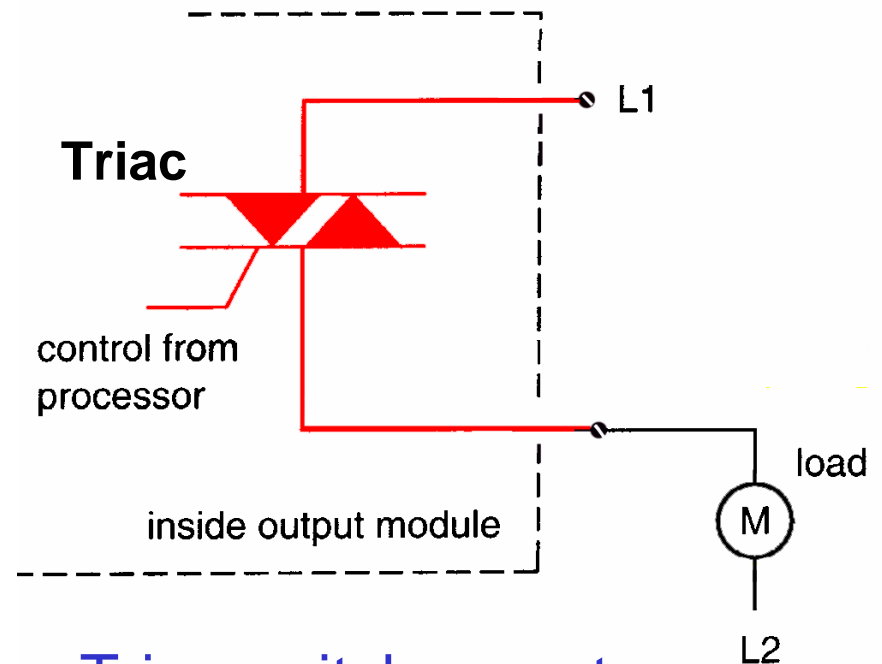
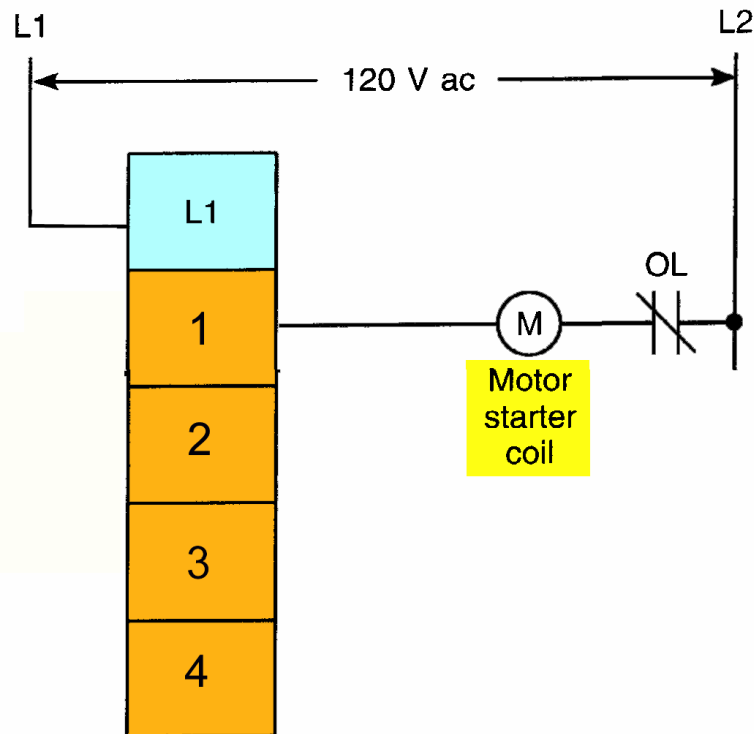

Triac switches motor ON and OFF in accordance with the control signal from the processor

PLC Ladder Logic Program

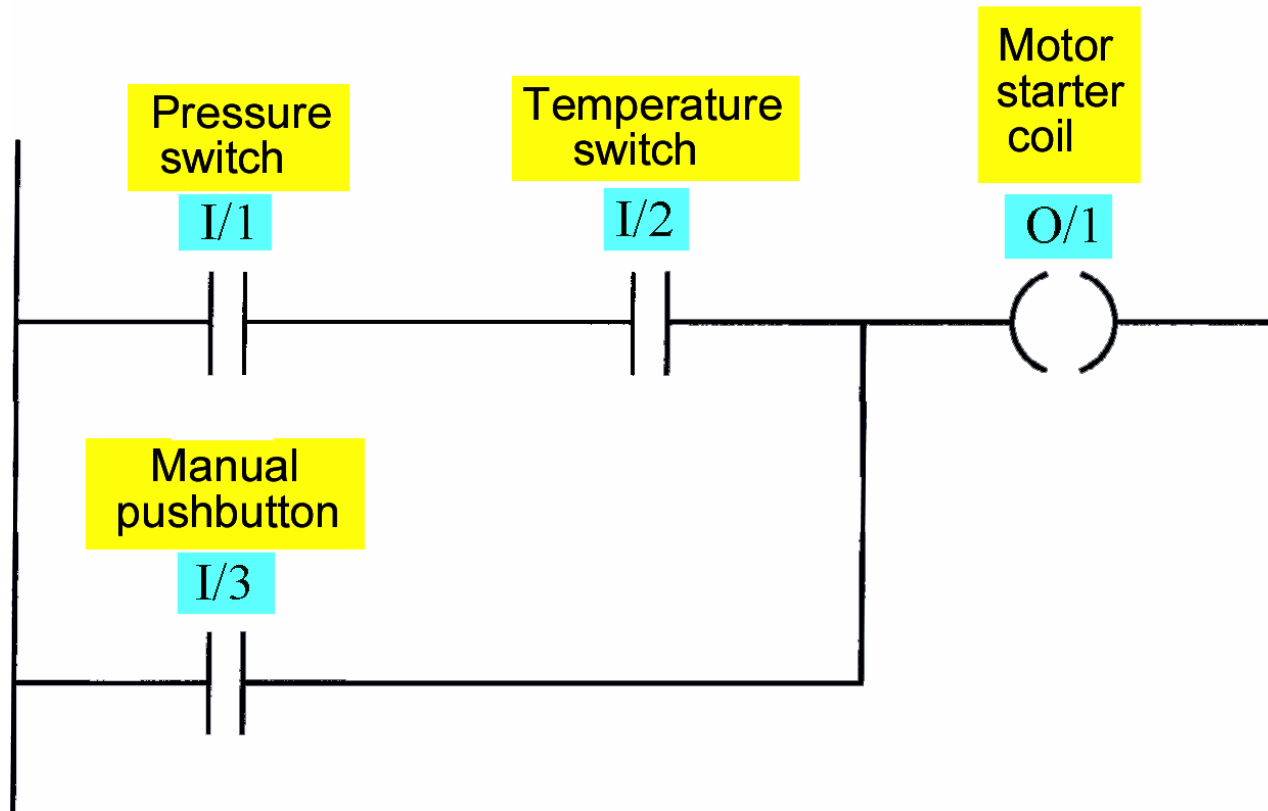

- The format used is similar to that of the hard-wired relay circuit

PLC Ladder Logic Program

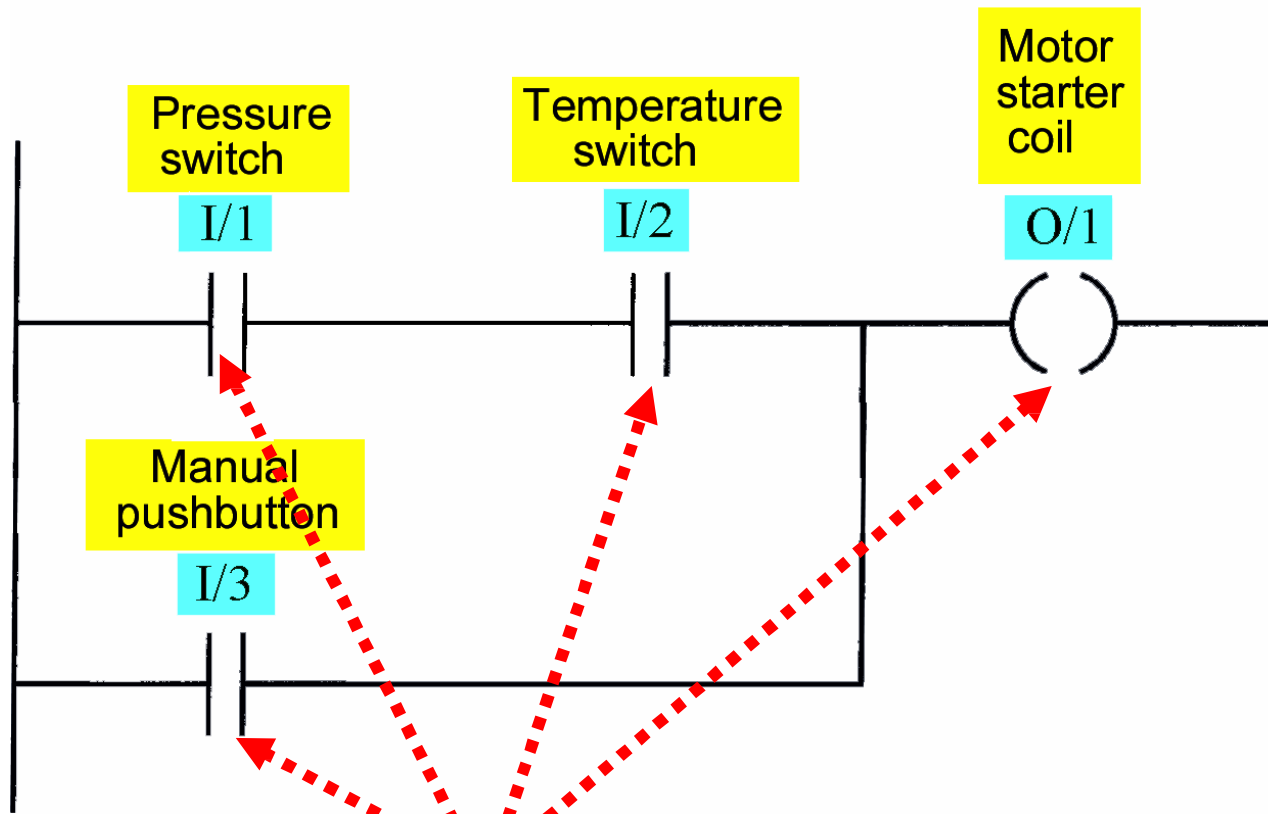

The symbols represent *instructions*

PLC Ladder Logic Program

The *numbers* represent *addresses*

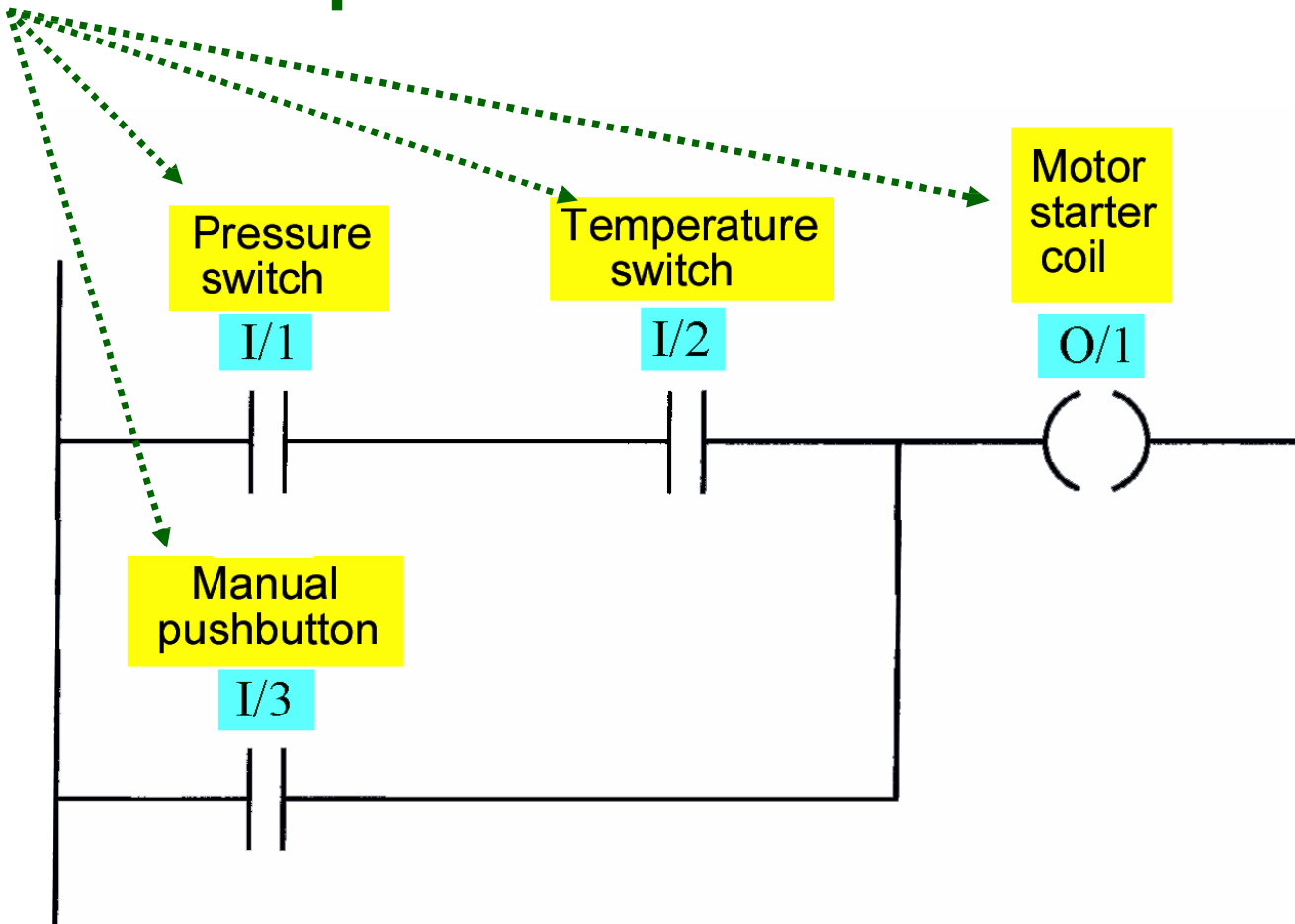

PLC Ladder Logic Program

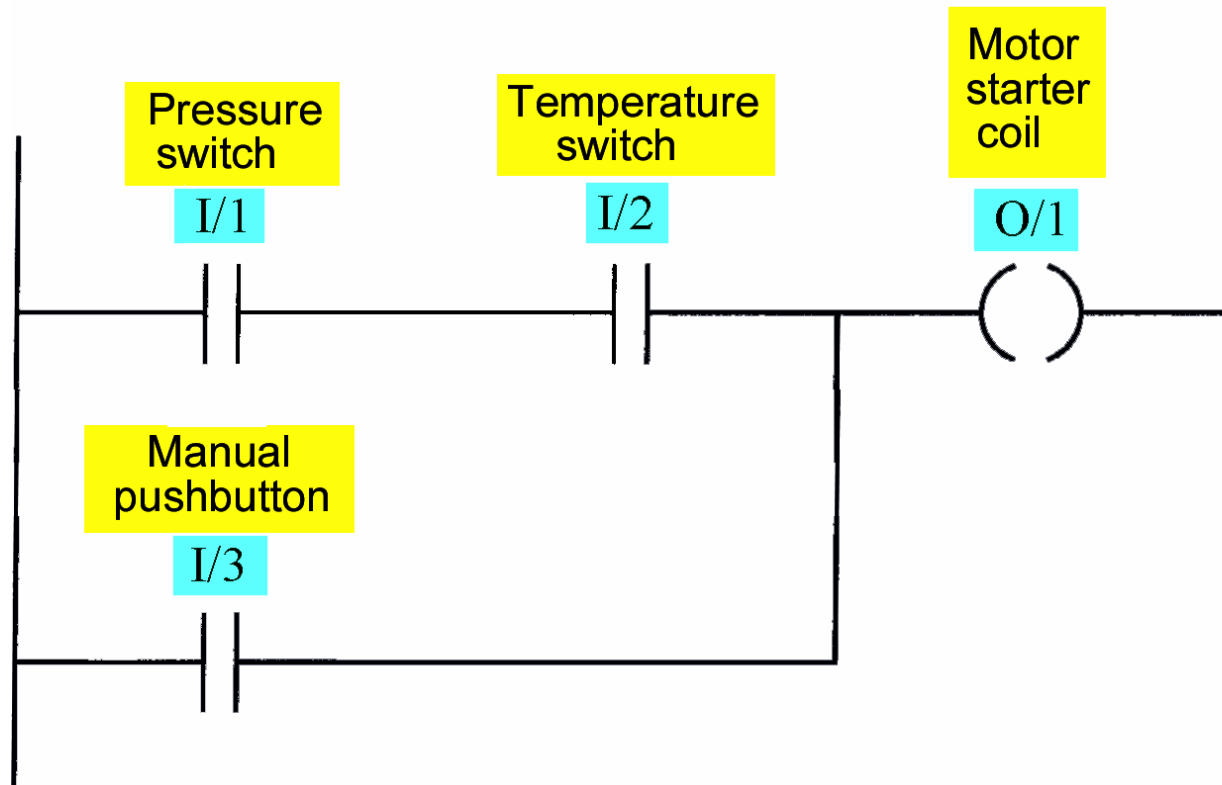

- I/O address format will differ, depending on the PLC manufacturer. You give each input and output device an address. This lets the PLC know where they are physically connected

Entering And Running The PLC Program

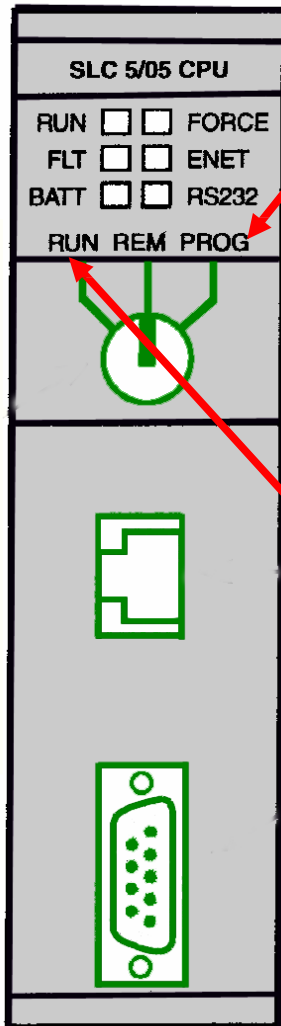

To enter the program into the PLC, place the processor in the PROGRAM mode and enter the instructions one-by-one using the programming device

To operate the program, the controller is placed in the RUN mode, or operating cycle

PLC Operating Cycle

During each operating cycle, the controller examines the status of input devices, executes the user program, and changes outputs accordingly

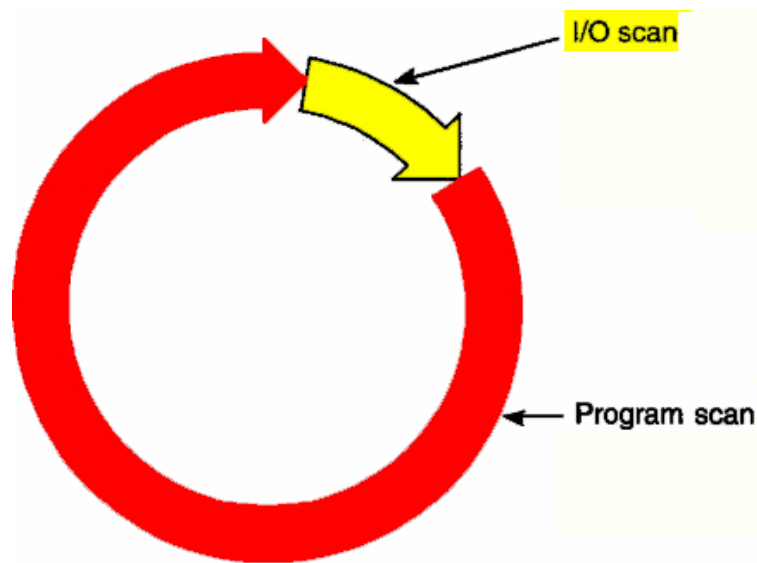

The completion of one cycle of this sequence is called a *scan*. The scan time, the time required for one full cycle, provides a measure of the speed of response of the PLC

PLC Operating Cycle

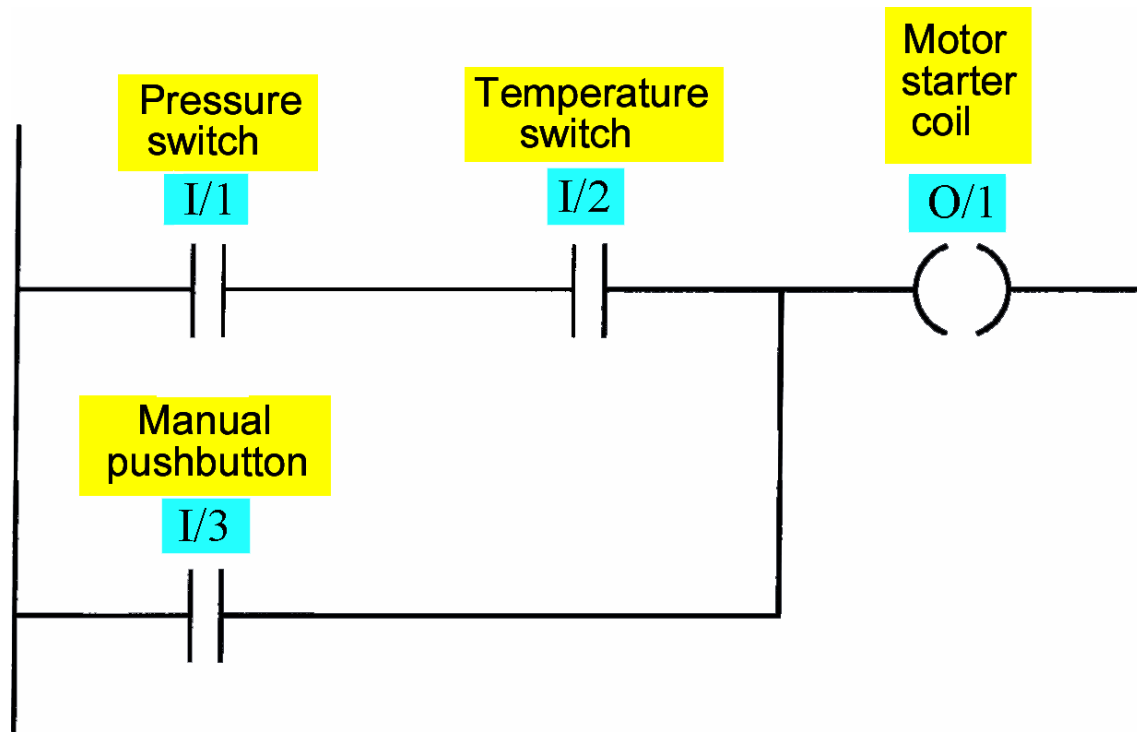

Each  can be thought of as a set of normally open contacts

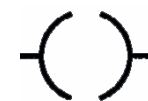
The  can be considered to represent a coil that, when energized, will close a set of contacts.

PLC Operating Cycle

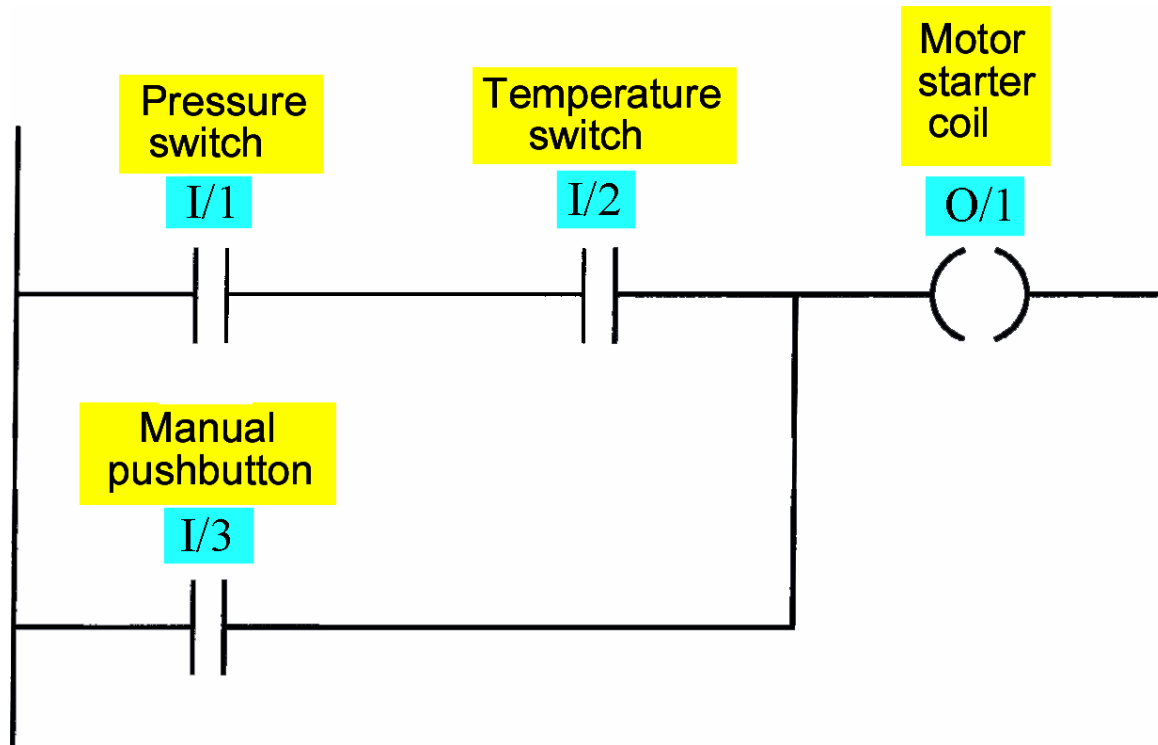

Coil O/1 is energized when contacts I/1 and I/2 are closed or when contact I/3 is closed. Either of these conditions provides a continuous path from left to right across the rung that includes the coil.

Modifying A PLC Program

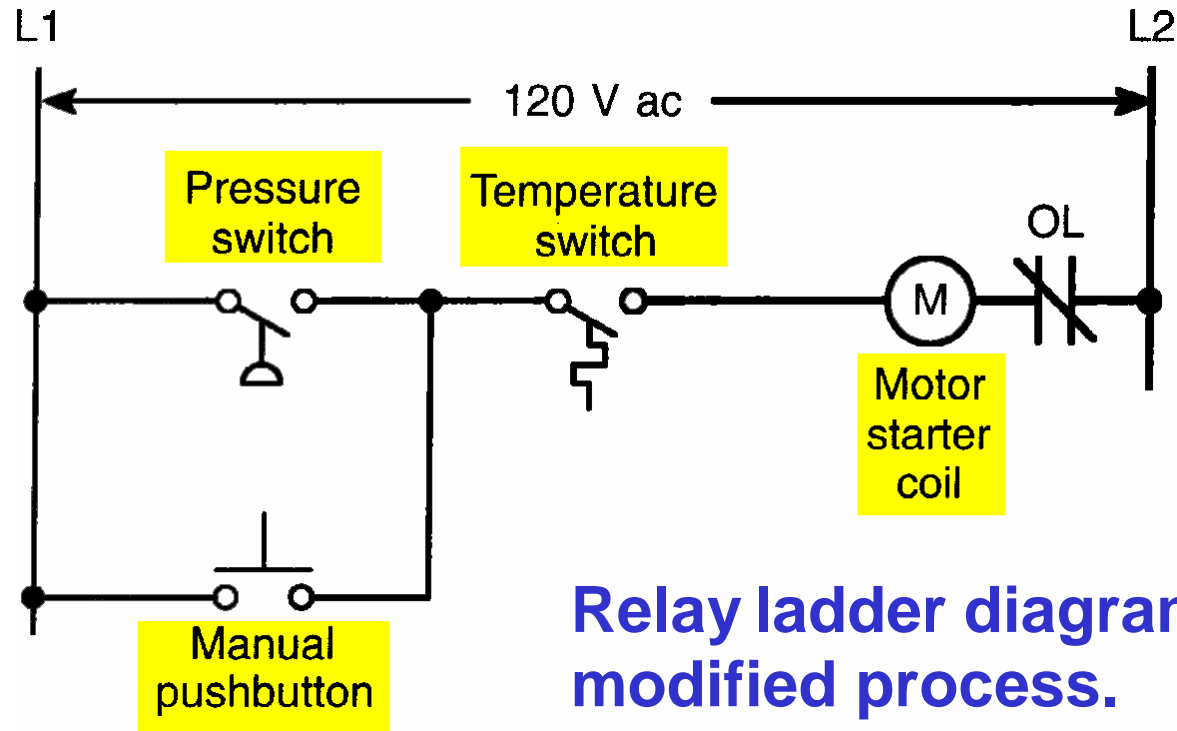

Relay ladder diagram for modified process.

The change requires that the manual pushbutton control should be permitted to operate at any pressure but not unless the specified temperature setting has been reached.

Modifying A PLC Program

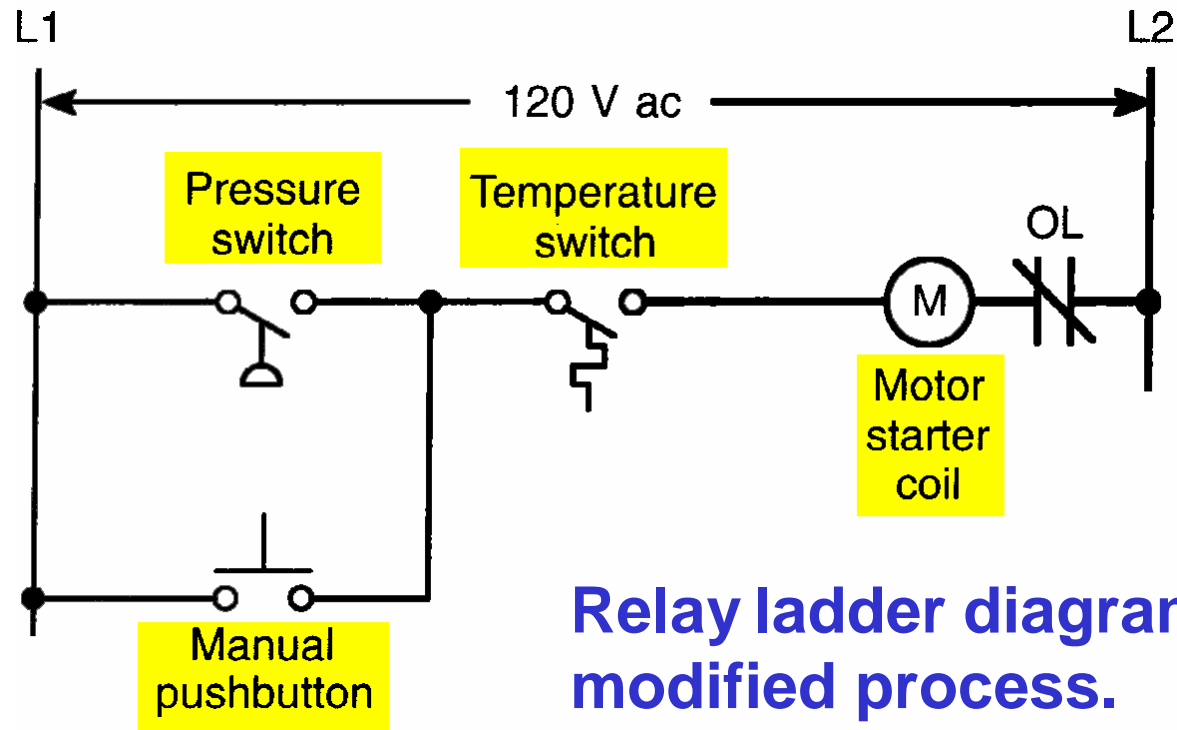

If a relay system were used, it would require some rewiring of the system, as shown, to achieve the desired change.

Modifying A PLC Program

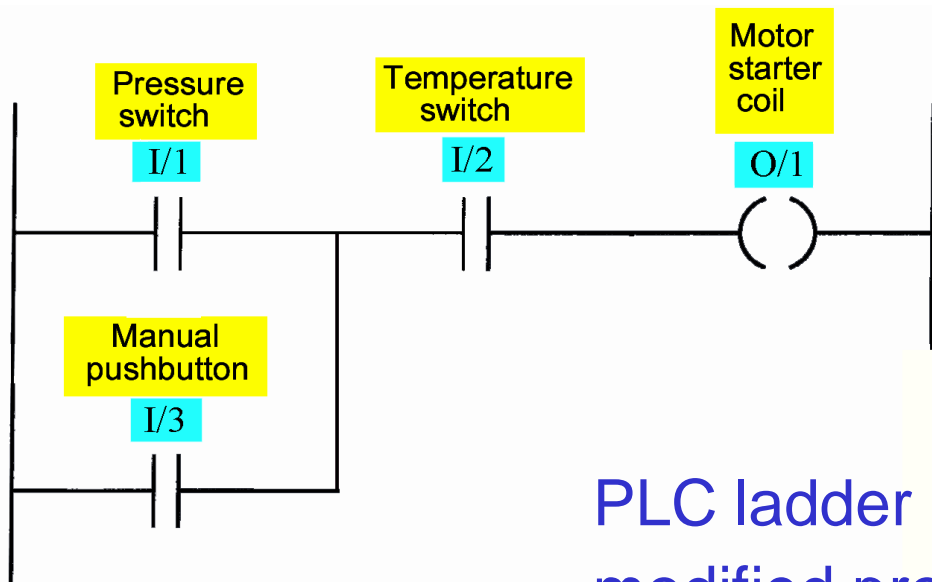

PLC ladder logic diagram for modified process.

If a PLC is used, no rewiring is necessary!

The inputs and outputs are still the same.

All that is required is to change the PLC program

PLCs Versus Personal Computers

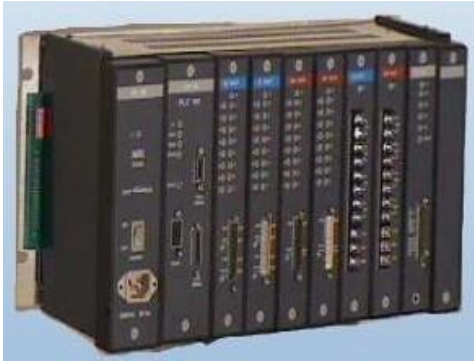

Same basic architecture



PLC

- Operates in the industrial environment
- Is programmed in relay ladder logic
- Has no keyboard, CD drive, monitor, or disk drive
- Has communications ports, and terminals for input and output devices

PC

- Capable of executing several programs simultaneously, in any order
- Some manufacturers have software and interface cards available so that a PC can do the work of a PLC

PC Based Control Systems

Advantages

- Lower initial cost
- Less proprietary hardware and software required
- Straightforward data exchange with other systems
- Speedy information processing
- Easy customization



PLC Size Classification

Criteria

- Number of inputs and outputs (I/O count)
- Cost
- Physical size



Nano PLC

- Smallest sized PLC
- Handles up to 16 I/O points

Micro PLC

- Handles up to 32 I/O points

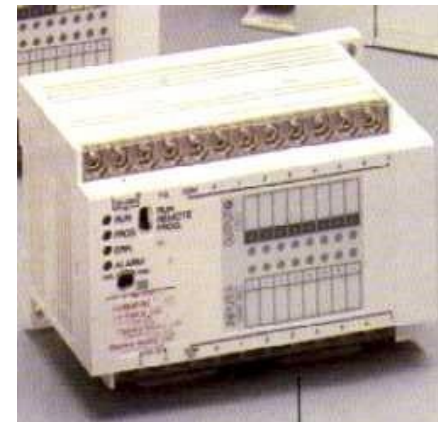

PLC Size Classification



Allen-Bradley SLC-500 Family
- Handles up to 960 I/O points



Allen-Bradley PLC-5 Family
- Handles several thousand I/O
points

PLC Instruction Set

The instruction set for a particular PLC type lists the different types of instructions supported.

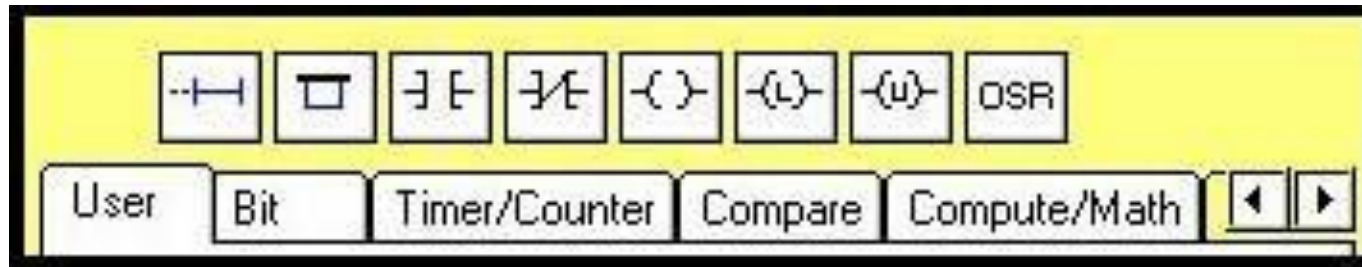

An instruction is a command that will cause a PLC to perform a certain predetermined operation.

Typical PLC Instructions

XIC (Examine ON)	Examine a bit for an ON condition
XIO (Examine OFF)	Examine a bit for an OFF condition
OTE (Output Energize)	Turn ON a bit (non retentive)
OTL (Output Latch)	Latch a bit (retentive)
OTU (Output Unlatch)	Unlatch a bit (retentive)
TOF (Timer Off-Delay)	Turn an output ON or OFF after its rung has been OFF a preset time interval
TON (Timer On-Delay)	Turn an output ON or OFF after its rung has been ON for a preset time interval
CTD (Count Down)	Use a software counter to count down from a specified value
CTU (Count Up)	Use a software counter to count up to a specified value