

**Lecture Notes**  
**On**  
**UTILIZATION OF ELECTRICAL ENERGY & TRACTION**



**5<sup>TH</sup> SEM, ELECTRICAL ENGG.**

**KIIT POLYTECHNIC**

**BHUBANESWAR**

## **Contents:**

Electrolysis

Electric Heating

Electric Welding

Illumination

Electric Drive

Electric Traction

# CHAPTER-1

## ELECTROLYSIS

---

### Definition and Basic principle of Electro Deposition.

Electro deposition is the process of coating a thin layer of one metal on top of different metal to modify its surface properties. It is done to achieve the desire electrical and corrosion resistance, reduce wear & friction, improve heat tolerance and for decoration.

### Electroplating Basics

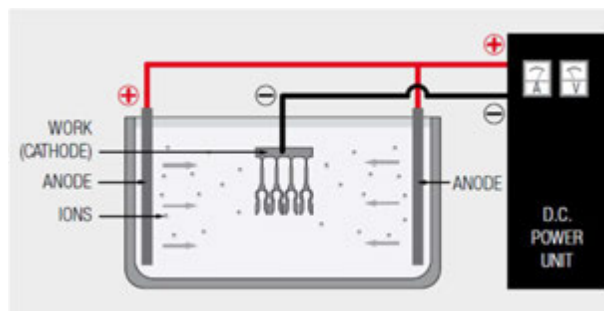

Fig-1. Electrochemical Plating

Figure- 1, schematically illustrates a simple electrochemical plating system. The “electro” part of the system includes the voltage/current source and the electrodes, anode and cathode, immersed in the “chemical” part of the system, the electrolyte or plating bath, with the circuit being completed by the flow of ions from the plating bath to the electrodes. The metal to be deposited may be the anode and be ionized and go into solution in the electrolyte, or come from the composition of the plating bath. Copper, tin, silver and nickel metal usually comes from anodes, while gold salts are usually added to the plating bath in a controlled process to maintain the composition of the bath. The plating bath generally contains other ions to facilitate current flow between the electrodes. The deposition of metal takes place at the cathode. The overall plating process occurs in the following sequence:

1. Power supply pumps electrons into the cathode.
2. An electron from the cathode transfers to a positively charged metal ion in the solution and the reduced metal plates onto the cathode.
3. Ionic conduction through the plating bath completes the circuit to the anode.
4. At the anode two different processes take place depending on whether the anode material is soluble, the source of the metal to be plated, or insoluble, inert. If the anode material is soluble, a metal atom gives up an electron and goes into the solution as a positively charged metal ion replenishing the metal content of the plating bath. If the anode is inert a negatively charged ion from the plating bath gives up an electron to the anode.
5. The electron flows from the anode to the power supply completing the circuit. The deposition of metal at the cathode requires an electron so the rate of deposition depends on the flow of

electrons, that is, the current flowing from the rectifier. The thickness of the deposit, therefore, depends on the current and the length of time the current is applied. This relationship is a result of Faraday's law which relates the weight of a substance produced by an anode or cathode electrode reaction during electrolysis as being directly proportional to the quantity of electricity passed through the cell.

### Faraday's Laws of Electrolysis

From his experiments, Faraday deduced two fundamental laws which govern the phenomenon of electrolysis. These are:

- (i) **First Law.** The mass of ions liberated at an electrode is directly proportional to the quantity of electricity i.e. charge which passes through the electrolyte.

**Or**

The weight of a substance liberated from an electrolyte in a given time is proportional to the quantity of electricity passing through the electrolyte.

That is  $W \propto Q \propto It$ , where  $I$  is the current and  $t$  is the time.

$$W = Zit$$

Where  $Z$  is a constant called electro-chemical equivalent.

If  $I = 1$  ampere and  $T =$  one second then,

$Z = W$ , which gives a definition of  $Z$ .

The electro-chemical equivalent of a substance is the amount of that substance by weight liberated in unit time by unit current.

- (ii) **Second Law.** The masses of ions of different substances liberated by the same quantity of electricity are proportional to their chemical equivalent weights.

or,

If the same current flows through several electrolytes, the weights of ions liberated are proportional to their chemical equivalents.

The chemical equivalent of a substance is the weight of the substance which can displace or combine with unit weight of hydrogen. Obviously, the chemical equivalent of hydrogen is 1 by definition.

### DEFINITIONS

#### 1. Current Efficiency

On account of the impurities which cause secondary reactions, the quantity of a substance liberated is less than that calculated from Faraday's Law.

Current efficiency is the ratio of the actual mass of a substance liberated from an electrolyte by the passage of current to the theoretical mass liberated according to Faraday's law. Current efficiency can be used in measuring electro deposition thickness on materials in electrolysis. Current efficiency is also known as faradic efficiency, faradic yield and columbic efficiency.

## 2. Energy Efficiency

On account of secondary reactions, the voltage actually required for the deposition or liberation of metal is higher than the theoretical value which increases the actual energy required.

Energy efficiency is defined as 
$$= \frac{\text{theoretical energy}}{\text{actual energy required}}$$

It is a process by which a metal is deposited over another metal or non-metal. Electro-plating is a very common example of such process.

Conditions have to be provided so that the deposit will be fine grained and will have a smooth appearance. The factors which affect the electro-deposition of metals are :

- (i) **Current Density**
- (ii) **Electrolyte concentration**
- (iii) **Temperature**
- (iv) **Addition agents**
- (v) **Nature of electrolyte**
- (vi) **Nature of the metal on which the deposit is to be made**
- (vii) **Throwing power of the electrolyte**

### Current density

At low values of current density the ions are released at a slow rate and the rate of growth of nuclei is more than the rate at which the new nuclei form themselves. Electro-deposition depends upon the rate at which crystals grow and the rate at which fresh nuclei are formed. Therefore, at low current densities the deposit will be coarse and crystalline in nature. At higher values of current density the quality of deposit becomes more uniform and fine-grained on account of the greater rate of formation of nuclei. If the current density is so high that it exceeds the limiting value for the electrolyte hydrogen is released and spongy and porous deposit is obtained.

### Electrolytic Concentration

This is more or less complementary to the first factor, i.e. current density, since by increasing the concentration of the electrolyte higher current density can be achieved.

Increase of concentration tends to give better deposits and therefore it is preferred in some processes.

### **Temperature**

The temperature of the electrolyte has two contradictory effects. One, at comparatively high temperature there is more diffusion and even at relatively high current density smooth deposits may be produced. Two, the rate of crystal growth increases the possibility of coarse deposits. At moderate temperatures, the deposits are good. In chromium plating the temperature is maintained at 35<sup>0</sup>C, and in nickel between 50<sup>0</sup>C to 60<sup>0</sup>C.

### **Addition Agents**

the quality of a deposit is improved by the presence of an addition agent which may be colloidal matter or an organic compound, otherwise the metal deposits in the form of large crystals and the surface becomes rough. Materials used as addition agents are gelatin, agar, glue, gums, rubber, alkaloids, sugar etc. The addition agents are supposed to be absorbed by crystal nuclei and prevent their growth into large crystals. The discharged ions start to build up new nuclei and the deposit of metal is fine-grained.

### **Nature of electrolyte**

Smooth deposits are obtained from solutions having complex ions, e.g., cyanides. Silver from nitrate solution forms a coarse deposit while from cyanide solution it forms a smooth deposit. Therefore, the formation of smooth deposit largely depends upon the nature of electrolyte used.

### **Nature of the metal on which deposit is to be made**

This factor influences the growth of crystals since it is believed that the operation of crystals is in continuation of these in the base metal.

### **Throwing Power**

The throwing power of an electrolyte may be regarded as the quality which produces a uniform deposit on a cathode having an irregular shape. Since the shape is irregular, The distance of the various parts of the cathode from the anode is not the same and therefore the conductance of the electrolyte is not the same for all parts of the cathode. The phenomenon of throwing power has not been clearly understood so far.

In an electrolyte of low conductance, the current will concentrate on the parts of the cathode which are nearer the anode resulting in poor throwing power. If the electrolyte has good conductance, the throwing power will also be good. One way to improve the throwing power is to keep a good distance between the cathode and the anode thereby providing more or less the same conductance for all parts of cathode. Presence of colloidal matter improves the throwing power but increase of temperature may produce the opposite effect.

### **Extraction of Metals**

This is done in two ways:

1. The ore is treated with a strong acid to obtain a salt and the solution of such a salt is electrolyzed to liberate the metal.
2. When the ore in molten state is available it is electrolysed in a furnace.

### **Extraction of Zinc**

The ore consisting of zinc is treated with concentrated sulphuric acid, roasted and passed through other processes to get rid of impurities by precipitation. The zinc-sulphate solution is then electrolysed. The cells consist of large lead-lined wooden boxes having aluminum cathodes and lead anodes. The current density is about 1000 amperes per square meter. Zinc is deposited on cathodes.

### **Extraction of Aluminium**

Ores of aluminium are bauxite and cryolite. Bauxite is treated chemically and reduced to aluminium oxide and then dissolved in fused cryolite and electrolysed. The furnace is lined with carbon. The temperature of the furnace is about  $1000^{\circ}$  C to keep the electrolyte in a fused state. Aluminium deposits at the cathode.

### **Refining of Metals**

Electrolytic extraction gives about 98 to 99 percent pure metal. Further refining is done by electrolysis. The anodes are made of the impure metal extracted from its ores and the electrolyte is a solution of the salt of the metal. Pure metal is deposited on the cathode.

Example: 1

A 20-cm long portion of a circular shaft 10 cm diameter is to be coated with a layer of 1.5 mm nickel. Determine the quantity of electricity in Ah and the time taken for the process. Assume a current density of 195 A/m<sup>2</sup> and a current efficiency of 92 percent. Specific gravity of nickel is 8.9.

Solution:

Wt. of nickel = 8.9 gm/cm<sup>3</sup>

Wt. of nickel to be deposited

$$= \pi \times 10 \times \frac{1.5}{10} \times 8.9 \times 10^{-3} \text{ kg}$$

Electro-chemical equivalent of nickel is 1.0954 kg per 1,000Ah.

Quantity of electricity required

$$= \frac{838.4 \times 10^{-3} \times 1,000}{1.0954 \times 0.92} = 833 \text{ Ahr}$$

Current density = 195 A/m<sup>2</sup> .

$$\text{Time taken} = \frac{833}{\pi \times 10 \times 20 \times 10^{-4} \times 195} = 68 \text{ hours.}$$

**XXXXXXXXXX**



## CHAPTER-2

# ELECTRICAL HEATING

---

Electric heating is extensively used both for domestic and industrial applications. Domestic applications include **(i)** room heaters **(ii)** immersion heaters for water heating **(iii)** hot plates for cooking **(iv)** electric kettles **(v)** electric irons **(vi)** pop-corn plants **(vii)** electric ovens for bakeries and **(viii)** electric toasters etc. Industrial applications of electric heating include **(i)** melting of metals **(ii)** heat treatment of metals like annealing, tempering, soldering and brazing etc. **(iii)** moulding of glass **(iv)** Baking of insulators **(v)** enamelling of copper wires etc.

### **Advantage of electrical heating:**

As compared to other methods of heating using gas, coal and fire etc., electric heating is far superior for the following reasons:

**(i) Cleanliness.** Since neither dust nor ash is produced in electric heating, it is a clean system of heating requiring minimum cost of cleaning.

**(ii) No Pollution.** Since no flue gases are produced in electric heating, no provision has to be made for their exit.

**(iii) Economical.** Electric heating is economical because electric furnaces are cheaper in their initial cost as well as maintenance cost since they do not require big space for installation or for storage of coal and wood. Moreover, there is no need to construct any chimney or to provide extra heat installation.

**(iv) Ease of Control.** It is easy to control and regulate the temperature of an electric furnace with the help of manual or automatic devices. Temperature can be controlled within  $\pm 5^{\circ}\text{C}$  which is not possible in any other form of heating.

**(v) Special Heating Requirement.** Special heating requirements such as uniform heating of a material or heating one particular portion of the job without affecting its other parts or heating with no oxidation can be met only by electric heating.

**(vi) Higher Efficiency.** Heat produced electrically does not go away waste through the chimney and other by products. Consequently, most of the heat produced is utilised for heating the material itself. Hence, electric heating has higher efficiency as compared to other types of heating.

**(vii) Better Working Conditions.** Since electric heating produces no irritating noises and also the radiation losses are low, it results in low ambient temperature. Hence, working with electric furnaces is convenient and cool.

**(viii) Heating of Bad Conductors.** Bad conductors of heat and electricity like wood, plastic and bakery items can be uniformly and suitably heated with dielectric heating process.

**(ix) Safety.** Electric heating is quite safe because it responds quickly to the controlled signals.

**(x) Lower Attention and Maintenance Cost.** Electric heating equipment generally will not require much attention and supervision and their maintenance cost is almost negligible. Hence, labour charges are negligibly small as compared to other forms of heating.

### Different Methods of Heat Transfer

The different methods by which heat is transferred from a hot body to a cold body are as under:

- I. Conduction
- II. Convection
- III. Radiation

#### I. Conduction

In this mode of heat transfer, one molecule of the body gets heated and transfers some of the heat to the adjacent molecule and so on. There is a temperature gradient between the two ends of the body being heated.

Consider a solid material of cross-section  $A$ sq.m. and thickness  $x$  metre as shown in Fig.1.

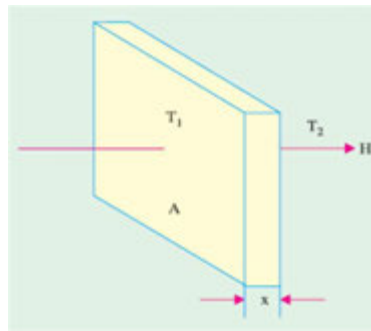

Fig-1

If  $T_1$  and  $T_2$  are the temperatures of the two sides of the slab in  $^{\circ}\text{K}$ , then heat conducted between the two opposite faces in time  $t$  seconds is given by:

$$H = \frac{KA (T_1 - T_2)t}{x} \dots (1)$$

Where,  $K$  is thermal conductivity of the material.

#### II. Convection

In this process, heat is transferred by the flow of hot and cold air currents. This process is applied in the heating of water by immersion heater or heating of buildings. The quantity of heat absorbed by the body by convection process depends mainly on the temperature of the heating element above the surroundings and upon the size of the surface of the heater. It also depends, to some extent, on the position of the heater. The amount of heat dissipated is given by  $H = a (T_1 - T_2)$ , where  $a$  is constant and  $T_1$  and  $T_2$  are

the temperatures of the heating surface and the fluid in °K respectively. In electric furnaces, heat transferred by convection is negligible.

### III. Radiation

It is the transfer of heat from a hot body to a cold body in a straight line without affecting the intervening medium. The rate of heat emission is given by Stefan's law, according to which heat dissipated is given by equation—2.

$$H = 5.72 eK \left[ \left( \frac{T_1}{100} \right)^4 - \left( \frac{T_2}{100} \right)^4 \right] \quad W/m^2 \quad \dots \dots (2)$$

Where, K is radiating efficiency and e is known as emissivity of the heating element. If d is the diameter of the heating wire and l its total length, then its surface area from which heat is radiated,

$$S = \pi dl \quad \dots (3)$$

If H is the power radiated per m<sup>2</sup> of the heating surface, then,

$$\text{Total power radiated as heat} = H\pi dl \dots (4)$$

If P is the electrical power input to the heating element, then

$$P = \pi dl \times H \quad \dots (5)$$

### *Resistance Heating.*

It is based on the I<sup>2</sup>R effect. When current is passed through a resistance element, I<sup>2</sup>R loss takes place which produces heat. There are two methods of resistance heating.

#### **(a) Direct Resistance Heating.**

In this method the material (or charge) to be heated is treated as a resistance and current is passed through it. The charge may be in the form of powder, small solid pieces or liquid. The two electrodes are inserted in the charge and connected to either a.c. or d.c. supply (Fig. 2). Obviously, two electrodes will be required in the case of d.c. or single-phase a.c. supply but there would be three electrodes in the case of 3-phase supply. When the charge is in the form of small pieces, a powder of high resistivity material is sprinkled over the surface of the charge to avoid direct short circuit. Heat is produced when current passes through it. This method of heating has high efficiency because the heat is produced in the charge itself.

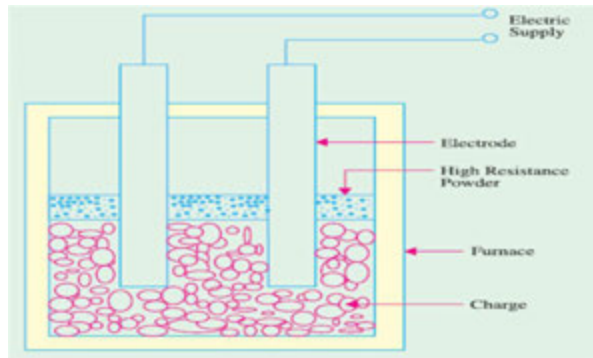

Fig:2 Direct Resistance heating

**b) In-Direct Resistance heating.**

In this method of heating, electric current is passed through a resistance element which is placed in an electric oven. Heat produced is proportional to  $I^2R$  losses in the heating element. The heat so produced is delivered to the charge either by radiation or convection or by a combination of the two. Sometimes, resistance is placed in a cylinder which is surrounded by the charge placed in the jacket as shown in the Fig.3. This arrangement provides uniform temperature. Moreover, automatic temperature control can also be provided.

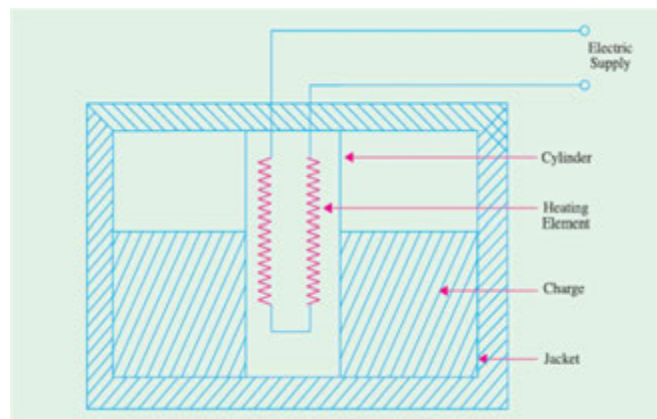

Fig-3 Indirect Resistance heating

**Principle of Resistance furnace.**

These are suitably-insulated closed chambers with a provision for ventilation and are used for a wide variety of purposes including heat treatment of metals like annealing and hardening etc., staving of enamelled wares, drying and baking of potteries, vulcanizing and hardening of synthetic materials and for commercial and domestic heating. Temperatures up to 1000°C can be obtained by using heating elements made of nickel, chromium and iron. Ovens using heating elements made of graphite can produce temperatures up to 3000°C. Heating elements may consist of circular wires or rectangular ribbons. The ovens are usually made of a metal framework having an internal lining of fire bricks. The heating element

may be located on the top, bottom or sides of the oven. The nature of the insulating material is determined by the maximum temperature required in the oven. An enclosure for charge which is heated by radiation or convection or both is called a **heating chamber**.



Fig. 4

## *Arc Furnaces*

If a sufficiently high voltage is applied across an air-gap, the air becomes ionized and starts conducting in the form of a continuous spark or arc thereby producing intense heat. When electrodes are made of carbon/graphite, the temperature obtained is in the range of 3000°C-3500C. The high voltage required for striking the arc can be obtained by using a step-up transformer fed from a variable a.c. supply as shown in Fig. 11 (a).

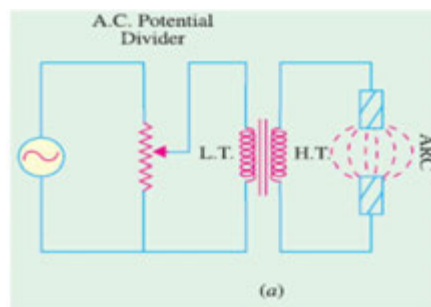

Fig-11

### Indirect Arc Furnace

In this case, arc is formed between the two electrodes and the charge in such a way that electric current passes through the body of the charge as shown in Fig.11(a) . Such furnaces produce very high temperatures. In this case, arc is formed between the two electrodes and the heat thus produced is passed on to the charge by radiation as shown in Fig. 47.11 (b).

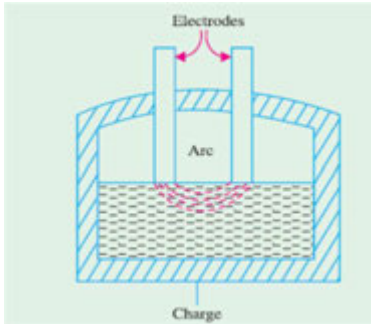

Fig-11(a)

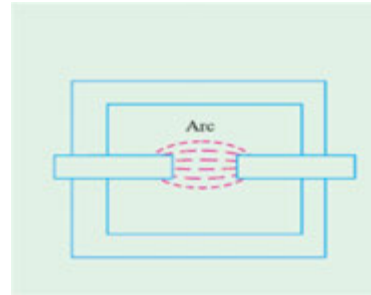

Fig-11(b)

### Direct Arc Furnace

It could be either of conducting-bottom type [Fig.12 (a)] or non-conducting bottom type [Fig.12 (b)]. As seen from Fig.12 (a), bottom of the furnace forms part of the electric circuit so that current passes through the body of the charge which offers very low resistance. Hence, it is possible to obtain high temperatures in such furnaces. Moreover, it produces uniform heating of charge without stirring it mechanically. In Fig.12 (b), no current passes through the body of the furnace. Most common application of these furnaces is in the production of steel because of the ease with which the composition of the final product can be controlled during refining. Most of the furnaces in general use are of non-conducting bottom type due to insulation problem faced in case of conducting bottom.

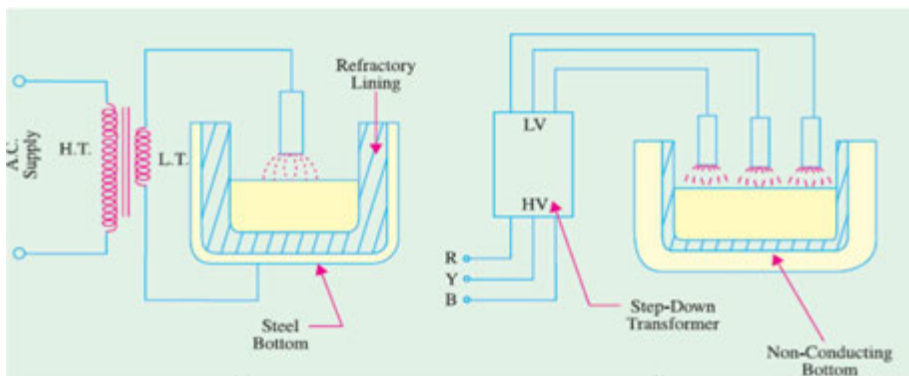

Fig-12(a)

Fig-12(b)

### Indirect Arc Furnace

Fig.13 shows a single-phase indirect arc furnace which is cylindrical in shape. The arc is struck by short circuiting the electrodes manually or automatically for a moment and then, withdrawing them apart. The heat from the arc and the hot refractory lining is transferred to the top layer of the charge by radiation. The heat from the hot top layer of the charge is further transferred to other parts of the charge by conduction. Since no current passes through the body of the charge, there is no inherent stirring action

due to electro-magnetic forces set up by the current. Hence, such furnaces have to be rocked continuously in order to distribute heat uniformly by exposing different layers of the charge to the heat of the arc. An electric motor is used to operate suitable grinders and rollers to impart rocking motion to the furnace. Rocking action provides not only thorough mixing of the charge, it also increases the furnace efficiency in addition to increasing the life of the refractory lining material. Since in this furnace, charge is heated by radiation only, its temperature is lower than that obtainable in a direct arc furnace. Such furnaces are mainly used for melting nonferrous metals although they can be used in iron foundries where small quantities of iron are required frequently.

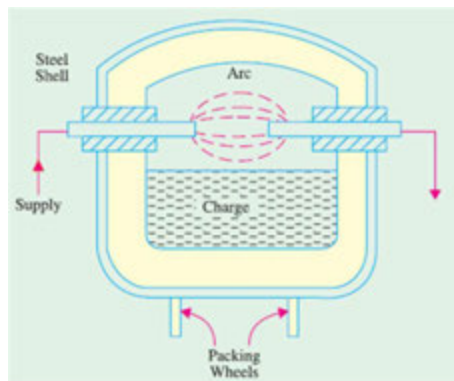

Fig-13

## Induction Heating

This heating process makes use of the currents induced by the electro-magnetic action in the charge to be heated. In fact, induction heating is based on the principle of transformer working. The primary winding which is supplied from an a.c. source is magnetically coupled to the charge which acts as a short circuited secondary of single turn. When an a.c. voltage is applied to the primary, it induces voltage in the secondary i.e. charge. The secondary current heats up the charge in the same way, as any electric current does while passing through a resistance. If  $V$  is the voltage induced in the charge and  $R$  is the charge resistance, then heat produced =  $V^2/R$ . The value of current induced in the charge depends on (i) magnitude of the primary current (ii) turn ratio of the transformer (iii) co-efficient of magnetic coupling. Low-frequency induction furnaces are used for melting and refining of different metals. However, for other processes like case hardening and soldering etc., high frequency eddy-current heating is employed. Low frequency induction furnaces employed for the melting of metals are of the following two types:

**(a) Core-type Furnaces** — It operates just like a two winding transformer. These can be further subdivided into (i) Direct core-type furnaces (ii) Vertical core-type furnaces and (iii) Indirect core-type furnaces.

**(b) Coreless-type Furnaces** — in which an inductively-heated element is made to transfer heat to the charge by radiation.

### Core Type Induction Furnace

It is shown in Fig.14 and is essentially a transformer in which the charge to be heated forms a single-turn short-circuited secondary and is magnetically coupled to the primary by an iron core. The furnace consists of a circular hearth which contains the charge to be melted in the form of an annular ring. When there is no molten metal in the ring, the secondary becomes open-circuited there-by cutting off the secondary current. Hence, to start the furnace, molten metal has to be poured in the annular hearth. Since, magnetic coupling between the primary and secondary is very poor, it results in high leakage and low power factor. In order to nullify the effect of increased leakage reactance, low primary frequency of the order of 10 Hz is used. If the transformer secondary current density exceeds 500 A/cm<sup>2</sup> then, due to the interaction of secondary current with the alternating magnetic field, the molten metal is squeezed to the extent that secondary circuit is interrupted. This effect is known as “pinch effect”.

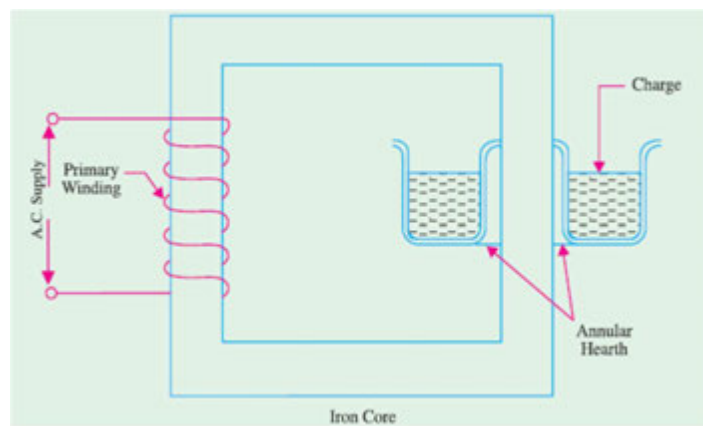

Fig-14

This furnace suffers from the following drawbacks:

1. It has to be run on low-frequency supply which entails extra expenditure on motor-generator set or frequency converter.
2. It suffers from pinching effect.
3. The crucible for charge is of odd shape and is very inconvenient for tapping the molten charge.
4. It does not function if there is no molten metal in the hearth i.e. when the secondary is open. Every time molten metal has to be poured to start the furnace.
5. It is not suitable for intermittent service. However, in this furnace, melting is rapid and clean and temperature can be controlled easily. Moreover, inherent stirring action of the charge by electro-magnetic forces ensures greater uniformity of the end product.



### **Vertical Core-Type Induction Furnace**

It is also known as Ajax-Wyatt furnace and represents an improvement over the core-type furnace discussed above. As shown in Fig.15, it has vertical channel (instead of a horizontal one) for the charge, so that the crucible used is also vertical which is convenient from metallurgical point of view. In this furnace, magnetic coupling is comparatively better and power factor is high. Hence, it can be operated from normal frequency supply. The circulation of the molten metal is kept up round the Vee portion by convection currents as shown in Fig.15. As Vee channel is narrow, even a small quantity of charge is sufficient to keep the secondary circuit closed. However, Vee channel must be kept full of charge in order to maintain continuity of secondary circuit. This fact makes this furnace suitable for continuous operation. The tendency of the secondary circuit to rupture due to pinch-effect is counteracted by the weight of the charge in the crucible. The choice of material for inner lining of the furnace depends on the type of charge used. Clay lining is used for yellow brass. For red brass and bronze, an alloy of magnetia and alumina or corundum is used. The top of the furnace is covered with an insulated cover which can be removed for charging. The furnace can be tilted by the suitable hydraulic arrangement for taking out the molten metal. This furnace is widely used for melting and refining of brass and other non-ferrous metals. As said earlier, it is suitable for continuous operation. It has a p.f. of 0.8-0.85. With normal supply frequency, its efficiency is about 75% and its standard size varies from 60-300 kW, all single phase.

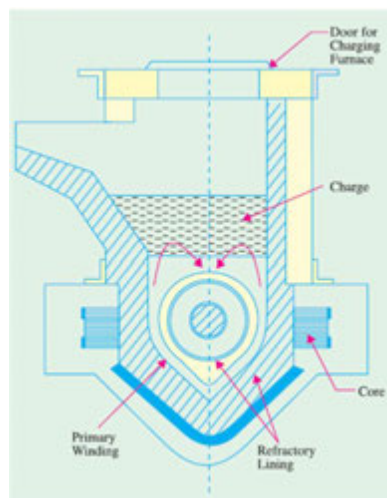

Fig-15 Core type Induction furnace

### **Indirect Core-Type Induction Furnace**

In this furnace, a suitable element is heated by induction which, in turn, transfers the heat to the charge by radiation. So far as the charge is concerned, the conditions are similar to those in a resistance oven. As shown in Fig.16, the secondary consists of a metal container which forms the walls of the furnace proper. The primary winding is magnetically coupled to this secondary by an iron core. When primary winding is connected to a.c. supply, secondary current is induced in the metal container by transformer action which

heats up the container. The metal container transfers this heat to the charge. A special advantage of this furnace is that its temperature can be automatically controlled without the use of an external equipment. The part AB of the magnetic circuit situated inside the oven chamber consists of a special alloy which loses its magnetic properties at a particular temperature but regains them when cooled back to the same temperature. As soon as the chamber attains the critical temperature, reluctance of the magnetic circuit increases manifold thereby cutting off the heat supply. The bar AB is detachable and can be replaced by other bars having different critical temperatures.

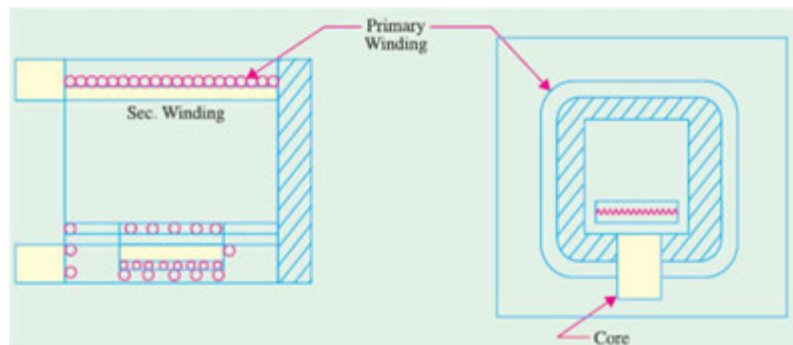

Fig-16

### Coreless Induction Furnace

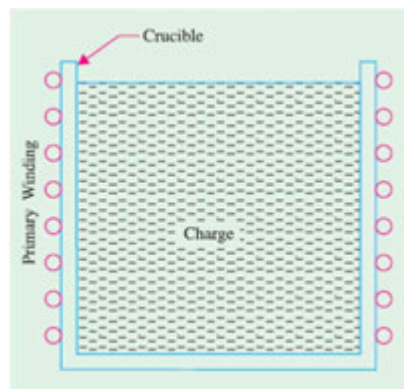

Fig-17

As shown in Fig.17, the three main parts of the furnace are **(i)** primary coil **(ii)** a ceramic crucible containing charge which forms the secondary and **(iii)** the frame which includes supports and tilting mechanism. The distinctive feature of this furnace is that it contains no heavy iron core with the result that there is no continuous path for the magnetic flux. The crucible and the coil are relatively light in construction and can be conveniently tilted for pouring. The charge is put into the crucible and primary winding is connected to a high-frequency a.c. supply. The flux produce by the primary sets up eddy-currents in the charge and heats it up to the melting point. The charge need not be in the molten state at

the start as was required by core-type furnaces. The eddy-currents also set up electromotive forces which produce stirring action which is essential for obtaining uniform quality of metal. Since flux density is low (due to the absence of the magnetic core) high frequency supply has to be used because eddy-current loss  $W_e \propto B_{\max}^2 f^2$ . However, this high frequency increases the resistance of the primary winding due to skin effect, thereby increasing primary Cu losses. Hence, the primary winding is not made of Cu wire but consists of hollow Cu tubes which are cooled by water circulating through them. Since magnetic coupling between the primary and secondary windings is low, the furnace p.f. lies between 0.1 and 0.3. Hence, static capacitors are invariably used in parallel with the furnace to improve its p.f. Such furnaces are commonly used for steel production and for melting of non-ferrous metals like brass, bronze, copper and aluminium etc., along with various alloys of these elements. Special applications of these furnaces include vacuum melting, melting in a controlled atmosphere and melting for precision casting where high frequency induction heating is used. It also finds wide use in electronic industry and in other industrial activities like soldering, brazing, hardening and annealing and sterilizing surgical instruments etc. Some of the advantages of coreless induction furnaces are as follows:

1. They are fast in operation.
2. They produce most uniform quality of product.
3. They can be operated intermittently.
4. Their operation is free from smoke, dirt, dust and noises.
5. They can be used for all industrial applications requiring heating and melting.
6. They have low erection and operating costs.
7. Their charging and pouring is simple.

## *Dielectric Heating*

It is also called high-frequency capacitive heating and is used for heating insulators like wood, plastics and ceramics etc. which cannot be heated easily and uniformly by other methods. The supply frequency required for dielectric heating is between 10-50 MHz and the applied voltage is up to 20 kV. The overall efficiency of dielectric heating is about 50%.

### **Dielectric Loss**

When a practical capacitor is connected across an a.c. supply, it draws a current which leads the voltage by an angle  $\phi$ , which is a little less than  $90^\circ$  or falls short of  $90^\circ$  by an angle  $\delta$ . It means that there is a certain component of the current which is in phase with the voltage and hence produces some loss called dielectric loss. At the normal supply frequency of 50 Hz, this loss is negligibly small but at higher frequencies of 50 MHz or so, this loss becomes so large that it is sufficient to heat the dielectric in which it takes place. The insulating material to be heated is placed between two conducting plates in order to form a parallel-plate capacitor as shown in Fig.19 (a). Fig.19 (b) shows the equivalent circuit of the capacitor and Fig.19 (c) gives its vector diagram.

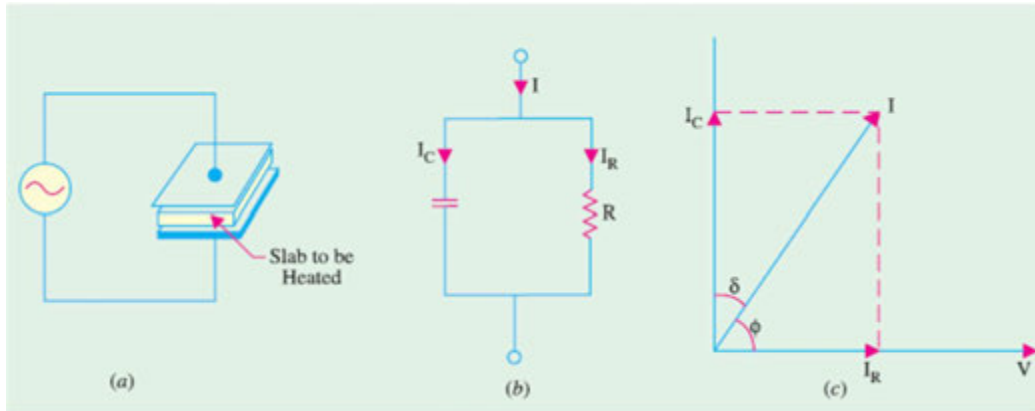

Fig-19

Power drawn from supply =  $VI \cos \phi$

Now,  $I_C = I = V/X_C = 2\pi f CV$

$\therefore P = V(2\pi f CV) \cos \phi = 2\pi f CV^2 \cos \phi$

Now,  $\phi = (90^\circ - \delta)$ ,  $\cos \phi = \cos (90^\circ - \delta) = \sin \delta = \tan \delta = \delta$

where  $\delta$  is very small and is expressed in radians.

$P = 2\pi f CV^2 \delta$  watts

Here,

$$C = \epsilon_0 \epsilon_r \frac{A}{d}$$

Where,  $d$  is the thickness and  $A$  is the surface area of the dielectric slab.

This power is converted into heat. Since for a given insulator material,  $C$  and  $\delta$  are constant, the dielectric loss is directly proportional to  $V^2 f$ . That is why high-frequency voltage is used in dielectric heating. Generally, a.c. voltage of about 20 kV at a frequency of 10-30 MHz is used.

### Advantages of Dielectric Heating

1. Since heat is generated within the dielectric medium itself, it results in uniform heating.
2. Heating becomes faster with increasing frequency.
3. It is the only method for heating bad conductors of heat.
4. Heating is fastest in this method of heating.
5. Since no naked flame appears in the process, inflammable articles like plastics and wooden products etc. can be heated safely.
6. Heating can be stopped immediately as and when desired.

# CHAPTER-3

## WELDING

---

### Definition

It is the process of joining two pieces of metal or non-metal at faces rendered plastic or liquid by the application of heat or pressure or both. Filler material may be used to effect the union.

### Welding Processes

All welding processes fall into two distinct categories:

**1. Fusion Welding**—it involves melting of the parent metal. Examples are:

(i) Carbon arc welding, metal arc welding, electron beam welding, electro-slag welding and electro-gas welding which utilize electric energy and

(ii) Gas welding and thermal welding which utilize chemical energy for the melting purpose.

**2. Non-fusion Welding**—It does not involve melting of the parent metal. Examples are:

(i) Forge welding and gas non-fusion welding which use chemical energy.

(ii) Explosive welding, friction welding and ultrasonic welding etc., which use mechanical energy.

(iii) Resistance welding which uses electrical energy.

Proper selection of the welding process depends on the (a) kind of metals to be joined (b) cost involved (c) nature of products to be fabricated and (d) production techniques adopted.

### Use of Electricity in Welding

Electricity is used in welding for generating heat at the point of welding in order to melt the material which will subsequently fuse and form the actual weld joint. There are many ways of producing this localised heat but the two most common methods are as follows:

**1. Resistance welding**—here current is passed through the inherent resistance of the joint to be welded thereby generating the heat as per the equation  $I^2Rt/J$  kilocalories.

**2. Arc welding**—here electricity is conducted in the form of an arc which is established between the two metallic surfaces

## Principle of arc welding

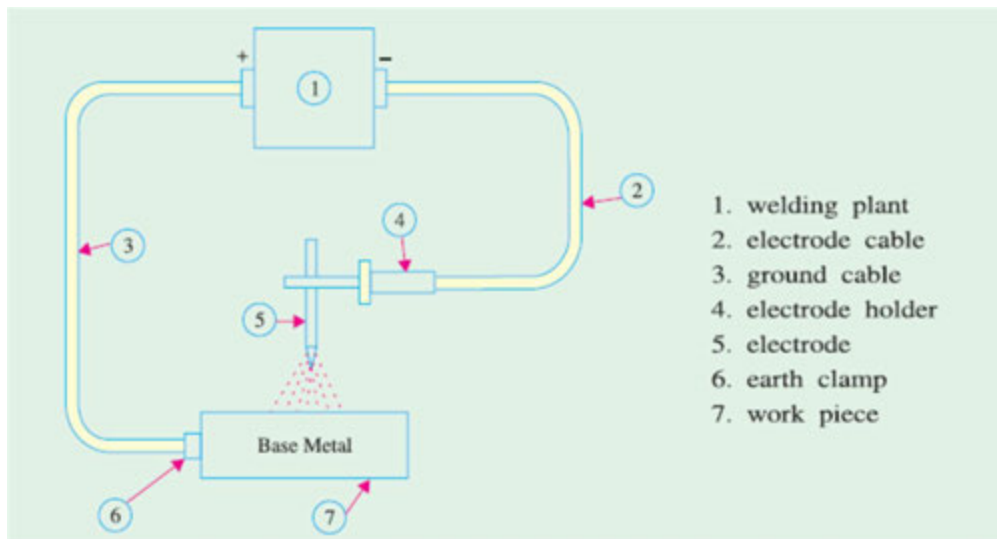

An electric arc is formed whenever electric current is passed between two metallic electrodes which are separated by a short distance from each other. The arc is started by momentarily touching the positive electrode (anode) to the negative metal (or plate) and then withdrawing it to about 3 to 6 mm from the plate. When electrode first touches the plate, a large short-circuits current flows and as it is later withdrawn from the plate, current continues to flow in the form of a spark across the air gap so formed. Due to this spark (or discharge), the air in the gap becomes ionized i.e. is split into negative electrons and positive ions. Consequently, air becomes conducting and current is able to flow across the gap in the form of an arc. As shown in Fig. 48.2, the arc consists of **lighter** electrons which flow from cathode to anode and **heavier** positive ions which flow from anode to cathode. Intense heat is generated when high velocity electrons strike the anode. Heat generated at the cathode is much less because of the low velocity of the impinging ions. It is found that nearly **two-third** of the heat is developed at the anode which burns into the form of a crater where temperature rises to a value of 3500-4000°C. The remaining one-third of the heat is developed near the cathode. The above statement is true in all d.c. systems of welding where positive side of the circuit is the hottest side. As a result, an electrode connected to the positive end of the d.c. supply circuit will burn 50% faster than if connected to the negative end. This fact can be used for obtaining desired penetration of the base metal during welding.

## Drooping Characteristics of welding

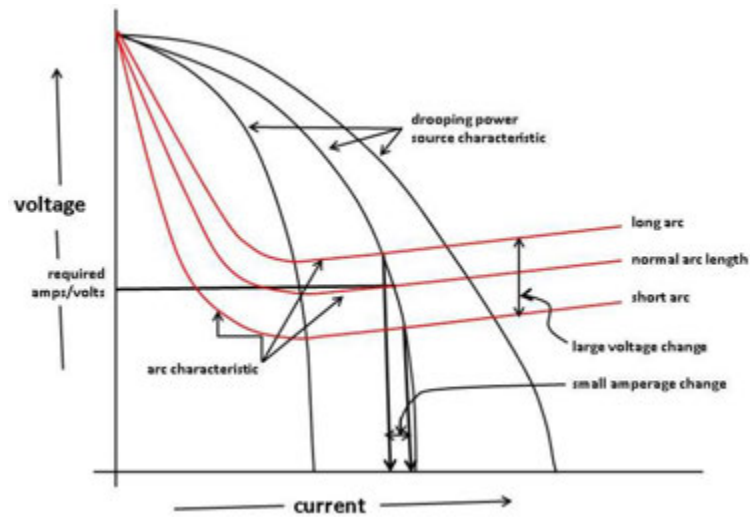

## DC Welding Plant

It consists of mainly a motor generator set. The motor is a squirrel cage induction motor and the generator is differentially compound to give drooping characteristics. In differential compound generator the terminal voltage falls automatically with increase in load current.

If the supply from the existing system is used then a ballast resistance is put in series with the equipment and control is obtained by variation of the external resistance. This method is also suitable when a number of operators are working on the same supply system. In such cases each operator is provided with separate ballast.

## AC Welding Plant

A transformer reduces the voltage from that of the supply drawn to about 100V. To regulate the current and produce the drooping characteristics, a resistance or reactance may be used.

The primary winding of the transformer is connected across a 2-phase system. The output from the secondary winding passes through a third winding to provide the balanced action. Current control is performed by this tertiary winding.

When a reactance is used it must be designed to operate well below the saturation point of its magnetic circuit to prevent the introduction of harmonics which tend to lengthen the zero current period in each half cycle and allow cooling of the arc.

## Carbon Arc Welding

### **(a) General**

Carbon arc welding was the first electric welding process developed by a French inventor Auguste de Meritens in 1881. In this process, fusion of metal is accomplished by the heat of an electric arc. No pressure is used and generally, no shielding atmosphere is utilized. Filler rod is used only when necessary. Although not used extensively these days, it has, nevertheless, certain useful fields of application. Carbon arc welding differs from the more common shield metal arc welding in that **it uses non-consumable carbon or graphite electrodes** instead of the consumable flux-coated electrodes.

## (b) Welding Circuit

The basic circuit is shown in Fig.3 and can be used with d.c. as well as a.c. supply. When direct current is used, the electrode is mostly negative (DCSP). The process is started by adjusting the amperage on the d.c.welder, turning welder ON and bringing the electrode into contact with the work piece. After the arc column starts, electrode is withdrawn 25 – 40 mm away and the arc is maintained at this distance. The arc can be extinguished by simply removing the electrode from the work piece completely. The only function of the carbon arc is to supply heat to the base metal. This heat is used to melt the base metal or filler rod for obtaining fusion weld Depending on the type and size of electrodes, maximum current values range from 15 A to 600 A for single-electrode carbon arc welding.

## (c) Electrodes

These are made of either carbon or graphite, are usually 300 mm long and 2.5 – 12 mm in diameter. Graphite electrodes are harder, more brittle and last longer than carbon electrodes. They can withstand higher current densities but their arc column is harder to control. Though considered non-consumable, they do disintegrate gradually due to vaporization and oxidization.

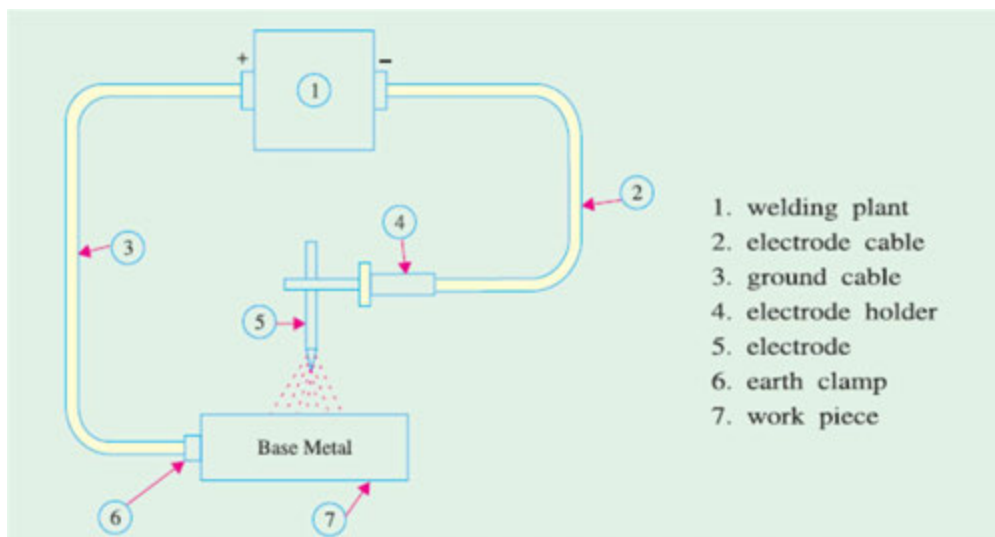

Figure. 3

## (d) Applications

1. The joint designs that can be used with carbon arc welding are butt joints, bevel joints, flange joints, lap joints and fillet joints.
2. This process is easily adaptable for automation particularly where amount of weld deposit is large and materials to be fabricated are of simple geometrical shapes such as water tanks.
3. It is suitable for welding galvanised sheets using copper-silicon-manganese alloy filler metal.
4. It is useful for welding thin high-nickel alloys.
5. Monel metal can be easily welded with this process by using a suitable coated filler rod.
6. Stainless steel of thinner gauges is often welded by the carbon-arc process with excellent results.



### (e) Advantages and Disadvantages

1. The main advantage of this process is that the temperature of the molten pool can be easily controlled by simply varying the arc length.
2. It is easily adaptable to automation.
3. It can be easily adapted to inert gas shielding of the weld and
4. It can be used as an excellent heat source for brazing, braze welding and soldering etc.

Its disadvantages are as under:

1. A separate filler rod has to be used if any filler material is required.
2. Since arc serves only as a heat source, it does not transfer any metal to help reinforce the weld joint.
3. The major disadvantage of the carbon-arc process is that blow holes occur due to magnetic arc blow especially when welding near edges of the work piece.

### Submerged Arc Welding

In this **fusion** process, welding is done under a blanket of granulated flux which shields the weld from all bad effects of atmospheric gases while a consumable electrode is continuously and mechanically fed into the arc. The arc, the end of the bare metal electrode and the molten weld pool are all submerged under a thick mound of finely-divided granulated powder that contains deoxidisers, cleansers and other fluxing agents. The fluxing powder is fed from a hopper that is carried on the welding head itself (Fig.23). This hopper spread the powder in a continuous mound ahead of the electrode in the direction of welding. Since arc column is completely submerged under the powder, there is no splatter or smoke and, at the same time, weld is completely protected from atmospheric contamination. Because of this protection, weld beads are extremely smooth. The flux adjacent to the arc column melts and floats to the top of the molten pool where it solidifies to form slag. This slag is easy to remove. Often it cracks off by itself as it cools. The unused flux is removed and is reused again and again.

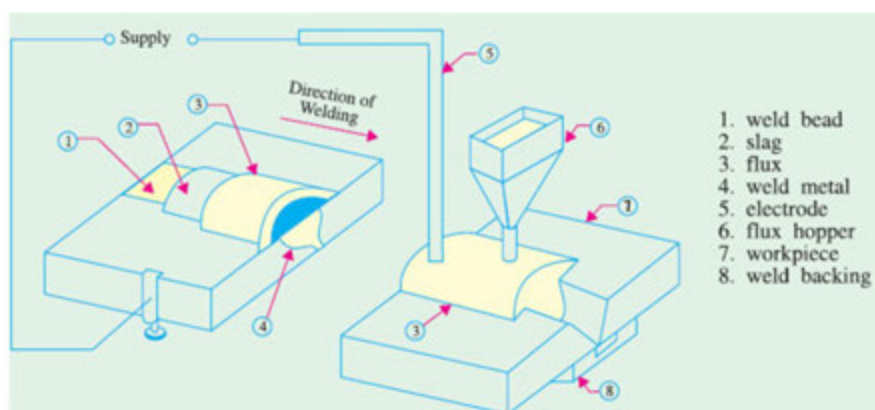

Fig-4

The electrode is either a bare wire or has a slight mist of copper coated over it to prevent oxidation. In automatic or semi-automatic submerged arc welding, wire electrode is fed mechanically through an

electrically contacting collect. Though a.c. power supply may be used, yet d.c. supply is more popular because it assures a simplified and positive control of the welding process. This process requires high current densities about 5 to 6 times of those used in ordinary manual stick electrode welding. As a result, melting rate of the electrode as well as welding speed become much higher. Faster welding speed minimizes distortion and war page. The submerged arc process is suitable for

1. Welding low-alloy, high-tensile steels.
2. Welding mild, low-carbon steels.
3. Joining medium-carbon steel, heat-resistant steels and corrosion-resistant steels etc.
4. Welding nickel, and other non-ferrous metals like copper. This process has many industrial applications such as fabrication of pipes, boiler pressure vessels, railroad tank cars, structural shapes etc. which demand welding in a straight line. Welds made by this process have high strength and ductility. A major advantage of this process is that fairly thick sections can be welded in a single pass without edge preparation. Submerged arc welding can be done manually where automatic process is not possible such as on curved lines and irregular joints. Such a welding gun is shown in Fig-24. Both manual and automatic submerged arc processes are most suited for flat and slightly downhill welding positions.

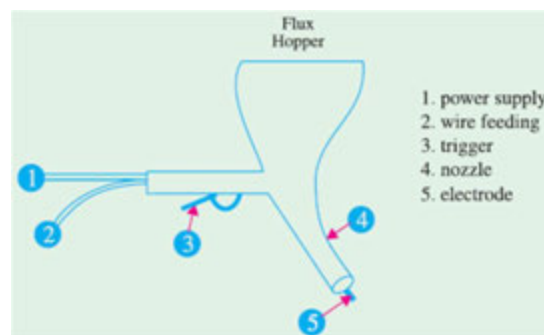

Fig-5

### **Twin Submerged Arc Welding**

As shown in Fig.25, in this case, two electrodes are used simultaneously instead of one. Hence, weld deposit size is increased considerably. Moreover, due to increase in welding current (upto 1500 A), much deeper penetration of base metal is achieved.

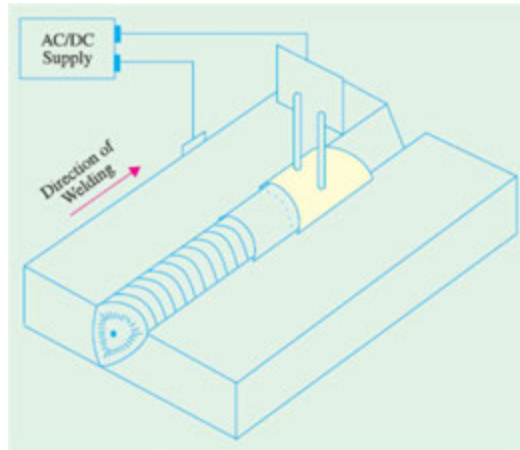

Fig-6

### Gas Shield Arc Welding

In this fusion process, welding is done with bare electrodes but weld zone is shielded from the atmosphere by a gas which is piped to the arc column. Shielding gases used are carbon dioxide, argon, helium, hydrogen and oxygen. No flux is required. Different processes using shielding gas are as follows.

#### **(a) Tungsten inert-gas (TIG) Process**

In this process, non-consumable tungsten electrode is used and filler wire is fed separately. The weld zone is shielded from the atmosphere by the inert gas (argon or helium) which is ducted directly to the weld zone where it surrounds the tungsten and the arc column.

#### **(b) Metal inert-gas (MIG) Process**

It is a refinement of the TIG process. It uses a bare consumable (i.e. fusible) wire electrode which acts as the source for the arc column as well as the supply for the filler material. The weld zone is shielded by argon gas which is ducted directly to the electrode point.

### Resistance Welding

It is fundamentally a heat and squeeze process. The term '**resistance welding**' denotes a group of processes in which welding heat is produced by the resistance offered to the passage of electric current through the two metal pieces being welded. These processes differ from the fusion processes in the sense that no extra metal is added to the joint by means of a filler wire or electrode. According to Joule's law, heat produced electrically is given by  $H = I^2Rt/J$ . Obviously, amount of heat produced depends on. **(i)** square of the current **(ii)** the time of current and **(iii)** the resistance offered. As seen, in simple resistance welding, high-amperage current is necessary for adequate weld. Usually, R is the contact resistance between the two metals being welded together. The current is

passed for a suitable length of time controlled by a timer. The various types of resistance welding processes may be divided into the following four main groups :

**(i)** spot welding **(ii)** seam welding **(iii)** projection welding and **(iv)** butt welding which could be further subdivided into flash welding, upset welding and stud welding etc.

## Advantages

Some of the advantages of resistance welding are as under :

1. Heat is localized where required
2. Welding action is rapid
3. No filler material is needed
4. Requires comparatively lesser skill
5. Is suitable for large quantity production
6. Both similar and dissimilar metals can be welded
7. Parent metal is not harmed
8. Difficult shapes and sections can be welded.

Only disadvantages are with regard to high initial as well as maintenance cost. It is a form of resistance welding in which the two surfaces are joined by spots of fused metal caused by fused metal between suitable electrodes under pressure.

## Spot Welding

The process depends on two factors:

1. Resistance heating of small portions of the two work pieces to plastic state and
2. Application of forging pressure for welding the two work pieces. Heat produced is  $H = I^2 R t / J$ . The resistance  $R$  is made up of (i) resistance of the electrodes and metals themselves (ii) contact resistance between electrodes and work pieces and (iii) contact resistance between the two work pieces. Generally, contact resistance between the two work pieces is the greatest.

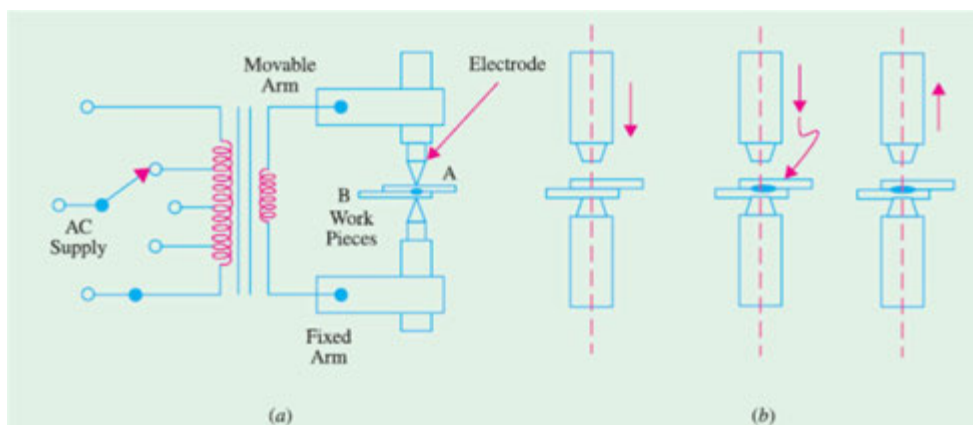

Fig-7

As shown in Fig-26 (b), mechanical pressure is applied by the tips of the two electrodes. In fact, these electrodes not only provide the forging pressure but also carry the welding current and concentrate the welding heat on the weld spot directly below them. Fig.26 (a) shows diagrammatically the basic parts of a modern spot welding. It consists of a step-down transformer which can supply huge currents (up to 5,000 A) for short duration of time. The lower arm is fixed whereas the upper one is movable. The electrodes are made of low-resistance, hard copper alloy and are either air cooled or butt-cooled by

water circulating through the rifled drillings in the electrode. Pointed electrodes [Fig.27 (a)] are used for ferrous materials whereas domed electrodes are used for non-ferrous materials. Flat domes are used when spot-welding deformation is not desired. The weld size is determined by the diameter of the electrode.

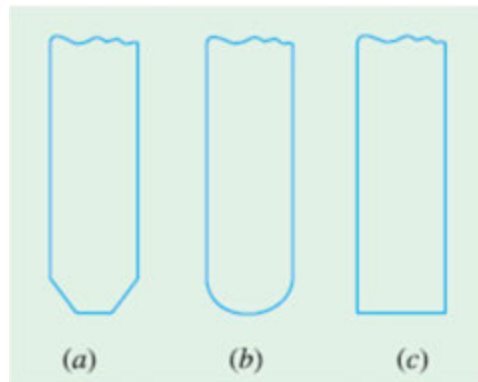

Fig-8

The welding machine is cycled in order to produce the required heat timed to coincide with the pressure exerted by the electrodes as shown in Fig.26 (a). As the movable electrode comes down and presses the two work pieces A and B together, current is passed through the assembly. The metals under the pressure zone get heated up to about 950°C and fuse together. As they fuse, their resistance is reduced to zero, hence there is a surge of current. This surge is made to switch off the welding current automatically. In motor-driven machines, speeds of 300strokes/minute are common. Spot welders are of two different types. One is a station arc welder which is available in different sizes. The other has a stationary transformer but the electrodes are in a gun form. Electric resistance spot welding is probably the best known and most widely-used because of its low cost, speed and dependability. It can be easily performed by even a semi-skilled operator. This process has a fast welding rate and quick set-up time apart from having low unit cost per weld. Spot welding is used for galvanized, tinned and lead coated sheets and mild steel sheet work. This technique is also applied to non-ferrous materials such as brass, aluminium, nickel and bronze etc.

### Seam Welding

The seam welder differs from ordinary spot welder only in respect of its electrodes which are of disc or roller shape as shown in Fig.28(a). These copper wheels are power driven and rotate whilst gripping the work. The current is so applied through the wheels that the weld spots either overlap as in Fig.28 (b) or are made at regular intervals as in Fig.28 (c). The continuous or overlapped seam weld is also called **stitch weld** whereas the other is called roll weld.

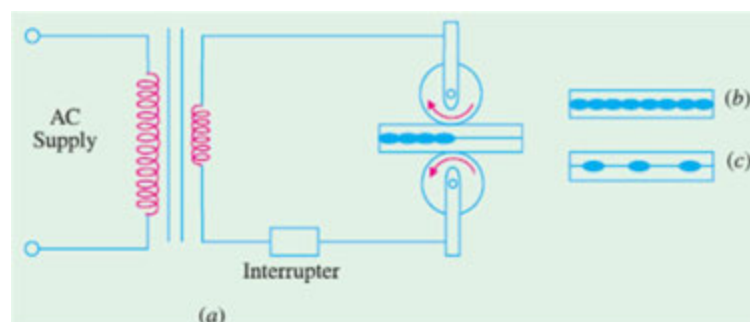

Fig-9

Seam welding is confined to welding of thin materials ranging in thickness from 2 mm to 5 mm. It is also restricted to metals having low harden ability rating such as hot-rolled grades of low alloy steels. Stitch welding is commonly used for long water-tight and gas-tight joints. Roll welding is used for simple joints which are not water-tight or gas-tight. Seam welds are usually tested by pillow test.

### Projection Welding

It can be regarded as a mass-production form of spot welding. Technically, it is a cross between spot welding and butt welding. It uses the same equipment as spot welding. However, in this process, large-diameter flat electrodes (also called platens) are used. This welding process derives its name from the fact that, prior to welding, projections are raised on the surfaces to be welded [Fig.29 (a)].

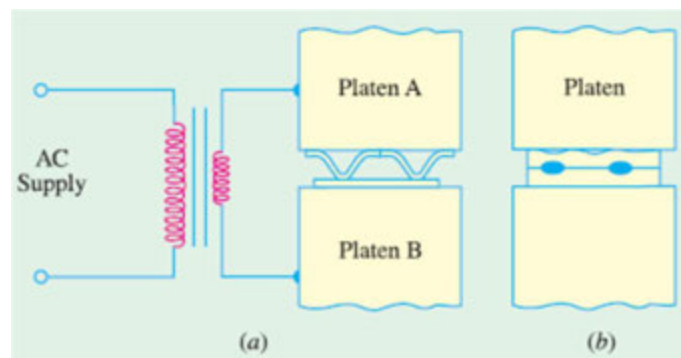

Fig-10

As seen, the upper and lower platens are connected across the secondary of a step-down transformer and are large enough to cover all the projections to be welded at one stroke of the machine. When platen A touches the work piece, welding current flows **through each projection**. The welding process is started by first lowering the upper platen A on to the work-piece and then applying mechanical pressure to ensure correctly-forged welds. Soon after, welding current is switched on as in spot welding. As projection areas heat up, they collapse and union takes place at all projections simultaneously [Fig.29(b)]. Projection welding is used extensively by auto manufactures for joining nuts, bolts and studs to steel plates in car bodies. This process is especially suitable for metals like brass, aluminium and copper etc. mainly due to their high thermal conductivity. A variation of projection welding is the metal fibre welding which uses a metal fibre rather than a projection point(Fig.30).

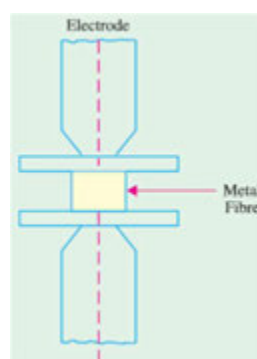

Fig-11

This metal fibre is generally a fill material. Instead of projections, tiny elements of this felt material are placed between the two metals which are then projection-welded in the usual way.

## Butt Welding

In this case, the two work pieces are brought into contact end-to-end and the butted ends are heated by passing a heavy current through the joint. As in other forms of resistance welding, the weld heat is produced mainly by the electrical resistance of the joint faces. In this case, however, the electrodes are in the form of powerful vice clamps which hold the work-pieces and also convey the forging pressure to the joint [Fig.31].

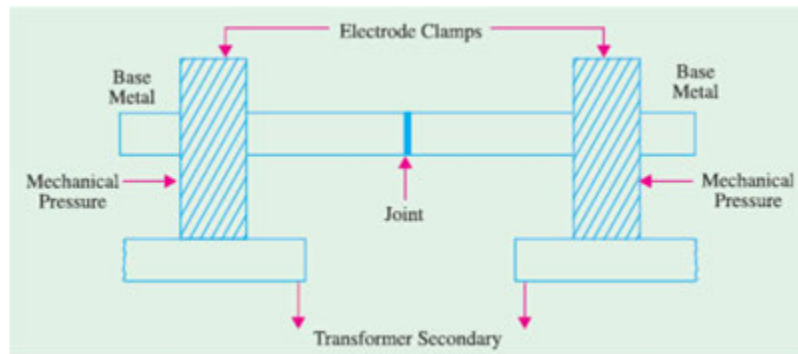

Fig-12

This process is useful where parts have to be joined end-to-end or edge-to-edge. i.e. for welding pipes, wires and rods. It is also employed for making continuous lengths of chain.

## **TYPES OF LIGHTING SCHEMES:**

The distribution of the light emitted by lamps is controlled by means of reflectors and translucent diffusing screens. The interior lighting schemes is classified as (a) direct lighting (b) semi-directing lighting (c) in directing lighting (d) general lighting.

**Direct lighting:** It is the most commonly used type of lighting scheme. In this scheme more than 90 percent of total light flux is made to fall directly on the working plane with the help of deep reflectors. It is mainly used for industrial and general outdoor lighting.

**Semi-direct lighting:** in this lighting scheme 60 to 90 percent of the total light flux is made to fall downwards directly with the help of semi direct reflectors, remaining light is used to illuminate the ceiling and walls. Such a lighting scheme is best suited to rooms with high ceilings where a high level of uniformly distributed illumination is desirable.

**Semi-indirect lighting:** In This lighting scheme 60 to 90 percent of total light flux is thrown upwards to the ceiling for diffuse reflection and the rest reaches the working plane directly except for some absorption by the bowl. This lighting scheme is with soft shadows and glare free. It is mainly used for indoor light decoration purposes.

**Indirect Lighting:** In this light scheme more than 90 percent of total light flux is thrown upwards to the ceiling for diffuse reflection by using inverted or bowl reflectors. in such a system the ceiling acts as the light source, and the glare is reduced to minimum. The resulting illumination is softer and more diffused, the shadows are more prominent and the appearance of room is more improved over which that results from direct lighting. it is used for decoration purposes in cinemas, theatres and hotel etc. and in workshops where large machines and other and obstructions would cause troublesome shadows if direct lighting is employed.

**General Lighting:** in this scheme lamps made of diffusing glass are used which give nearly equally illumination in all directions.

## **GAS DISCHARGE LAMP:**

The basic principle of a gaseous discharge lamp as shown in fig. Gases are normally poor conductors at atmospheric and high pressures. When application of suitable voltage, known as ignition voltage across the two electrodes, as result in a discharge through the gas which is accompanied by electromagnetic radiation. The wave-length of this radiation depends upon the gas, its pressure and the metal vapour used in lamp.

Once the ionization has commenced in the gas, it has a tendency to increase continuously accompanied by a fall in the circuit resistance. In order to limit the current to a safe value of a choke or ballast is made. The choke performs the dual functions of providing the ignition voltage initially and limiting the current. Since due to use of choke the power factor becomes poor, i.e.0.3-0.4 .Therefore in order to improve the power factor of the gaseous discharge lamp use of a condenser. The colour of the light obtained depends upon the nature of the gas or vapour used.



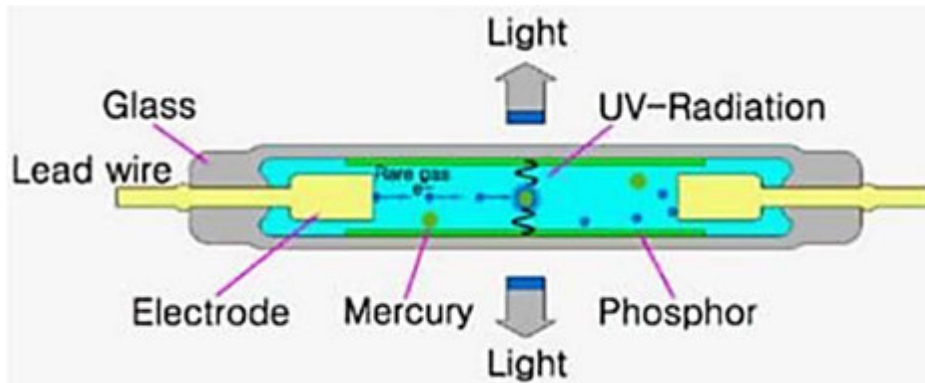

Fig. 4. Gaseous Discharge Lamp

The production of light by these lamps is based on the phenomenon of excitation and ionization in a gas or vapour. An atom has a positive nucleus and one or more electrons revolving around it in certain fixed orbits. In certain solids and gases there are free electrons which can escape from the influence of the nucleus of one atom and go over to another atom. There are thus a number of electrons which are mobile in nature. If a potential difference is applied to two electrodes placed in a gas having a large number of free electrons, these electrons will be attracted to the positive electrode and the velocity acquired by an electron will depend upon the potential gradient. During its motion towards the positive electrode, an electron will strike other atoms and one or more of the following results may be produced.

- ELASTIC COLLISION

The electron may be bounced off the atom it strikes and there may be no change in its velocity. This happens when the striking electron has a small amount of kinetic energy.

- EXCITATION

If the electron has acquired kinetic energy above a certain critical value in the process of passing through a certain potential which is termed as the excitation potential, the collision may cause one of the electrons to jump from its normal orbit into another one. This happens when the colliding electron has a kinetic energy of 2.1eV. The colliding electron imparts its kinetic energy to the atom that it strikes and this atom is said to be in an excited state. In this way the atoms can be placed in the 1<sup>st</sup>, 2<sup>nd</sup>, 3<sup>rd</sup>, 4<sup>th</sup> or higher excited states depending upon the kinetic energy of the colliding electron.

- IONISATION BY COLLISION

If the kinetic energy of the colliding atom is large, it will completely knock out an electron from its orbit and this electron will now behave like a free electron and may produce more free electrons by collision. A large number of free electrons thus produced constitute a heavy current and an electric arc may result. This phenomenon is called *ionization*. Ionization potential is the potential difference through which an electron must travel to acquire energy for ionization by collision.

## Neon Lamp

These belong to the cold-cathode category. The electrodes are in the form of iron shells and are coated on the inside. The colour of the light emitted is red and these lamps are mostly used for electrical advertising. High voltage is used for starting. If helium gas is used for in place of neon, pinkish white light is obtained. Helium and neon through coloured glass tubing produce a variety of effects. Figure

below shows a circuit for a neon lamp. The transformer has a high leakage reactance, which stabilize the arc in the lamp. A capacitor is used for power factor improvement.

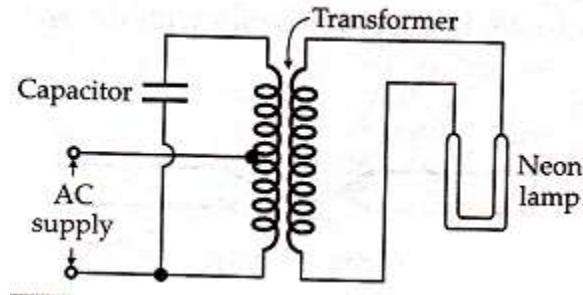

Fig. 5. Neon Lamp

## Sodium Vapour lamp

Sodium vapour has the highest theoretical luminous efficiency and gives monochromatic orange-yellow light. The monochromatic light makes objects appear grey. Such lamps on account of this factor are used only for street and highway lighting.

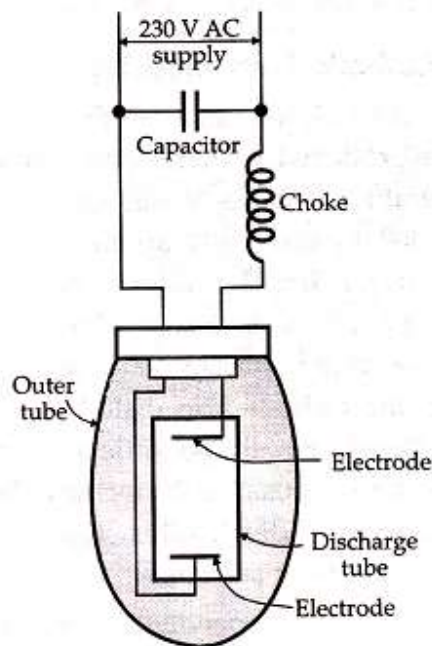

Fig. 6 Sodiun Vapour Lamp

The Lamp consists of a discharge tube having special composition of glass to withstand the high temperature of the electric discharge. The discharge tube is surrounded by an outer tube as shown below. For heating the cathode a transformer is included. Sodium below  $60^{\circ}\text{C}$  is in solid state. For starting the

lamp the electric discharge is allowed to take place in neon gas. The temperature inside the discharge tube rises and vapourises sodium. Operating temperature is around  $230^{\circ}\text{C}$ . It takes about 10 minutes for the sodium vapour to displace the red colour of neon by its brown yellow colour. The lamp takes about half an hour to reach full output. A choke is providing for stabilizing the electric discharge and a capacitor for power factor improvement. The light output is about 40 to 50 lumens per watt.

## Mercury Vapour Lamp

It is similar in construction to the sodium vapour lamp. The electrodes are tungsten coils containing an electron emitting material which may be a small piece of thorium or an oxide mixture. Argon is introduced to help start the lamp. The electric discharge first takes place through argon and this vaporizes the mercury inside the discharge tube. The electron emitting material supplies electrons to maintain the arc.

The space between the two bulbs is filled with an inert gas. The pressure inside the discharge tube may range from one to ten atmospheres in lamps used for lighting purposes as at these pressures the radiation is in the visible spectrum. If the pressure inside the discharge tube is low, most of the light is in the ultraviolet region. The efficiency is 30 to 40 lumens per watt.

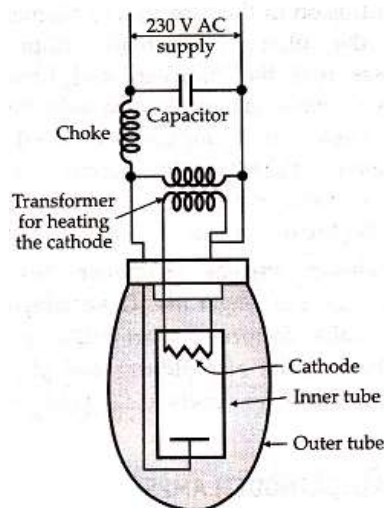

Fig.7 High pressure Mercury vapour Lamp

## Fluorescent Lamp

In the mercury vapour lamp considerable amount of radiation is in the ultra violet range. By coating the inside of the tube by phosphor this ultra violet radiation is converted in visible light. Phosphors have definite characteristic colours but when mixed together they produce a large variety of colours. These phosphors are stable compounds and give a high output throughout the life of the lamp.

There are three types of fluorescent lamps:

1. Iron cathode or cold cathode type
2. Tungsten cathode, pre-heated type
3. Tungsten cathode, cold

### Cold cathode type

In the cold cathode discharge tube under normal operating conditions which depend on the type and pressure of the gas and the type of electrodes, a glow discharge takes place which is discontinuous near the cathode where crookes and faraday dark space occur due to the formation of space charges in the gas. There is fairly large fall in voltage in this region. Then there is the positive column which provides useful illumination. The voltage drop along the positive column is proportional to its length. The large voltage drop at the cathode is independent of the tube length and depends only on the cathode material and the gas pressure. It may be between 100 and 200 volts. If, therefore, a cold cathode tube was to be operated from the mains, it would be very inefficient since most of the voltage will be utilized in overcoming the cathode voltage drop. It becomes necessary to use high voltage for the economic operation of this type of lamp. Also, the lamp is not efficient unless its length is considerable. However, cold cathode tubes are of smaller diameter and can give any shape which makes them suitable for display and advertisement purpose.

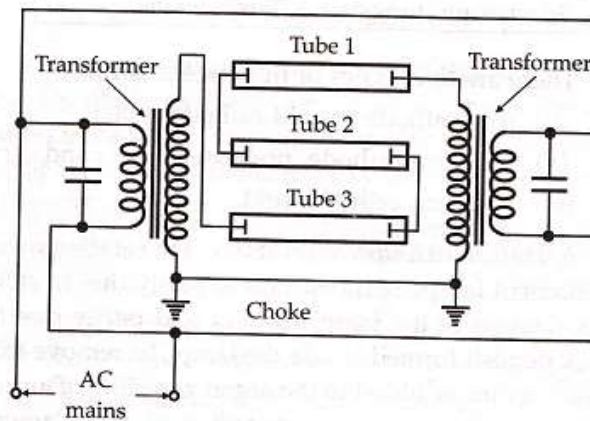

Fig. 8 Operation of the cold cathode lamps in series

### Tungsten Cathode Preheated Type

In tungsten cathode preheated type electrons are produced by thermionic emission. Lower starting operating voltages are adequate. A transient voltage of 300 to 600 volts applied by the starter initiates the arc stream. The coating material decays in each starting of the lamp. The constant impact of electrons on the cathode also dislodges some of the emitting material. Finally so little of the materials is left that it is not possible to emit any electrons and the lamp becomes dead. This type of lamp is unsuitable for frequent starting

Fluorescent lamps produce flicker or stroboscopic effect since on 50 cycle supply they are extinguished 100 times a second. Single lamp cannot be operated without flicker. Flicker correction can be applied to pairs of lamps.

Radio interference is another effect produced by fluorescent lamps and has to be removed by suitable filter circuits. The advantage of fluorescent lamp is that its efficiency and life under normal conditions are almost three times those for filament lamps. The quantity of light obtained is superior, glare is minimum and the fluorescent light source casts soft shadows. However, the initial cost of the lamp and filling is higher than the incandescent lamps.

Starters of automatic starting switches are of two types:

1. Thermal Type
2. Glow discharge Type

The thermal starter has a heater coil which heats a bimetallic switch. The heater coil remains energized to keep the bimetallic switch open throughout the operation. It therefore, consumes a small amount of power. Figure below shows the circuit diagram of fluorescent lamp started by a thermal starter. When the supply is switched on the contacts of the bimetallic switch are closed and the current passes through the electrodes and heats them up. But after an interval of a few seconds the heater coil heats up the bimetallic strip and the bimetallic switch contacts open. This starts a high voltage transient across the electrode due to the presence of the choke or ballast in the circuit. An arc is struck between the electrodes due to the high voltage transient. The identical circuit showing the use of a glow starter can also be used as shown. The glow starter is enclosed in a glass bulb filled with neon or argon. One of the electrodes is a bimetallic strip.

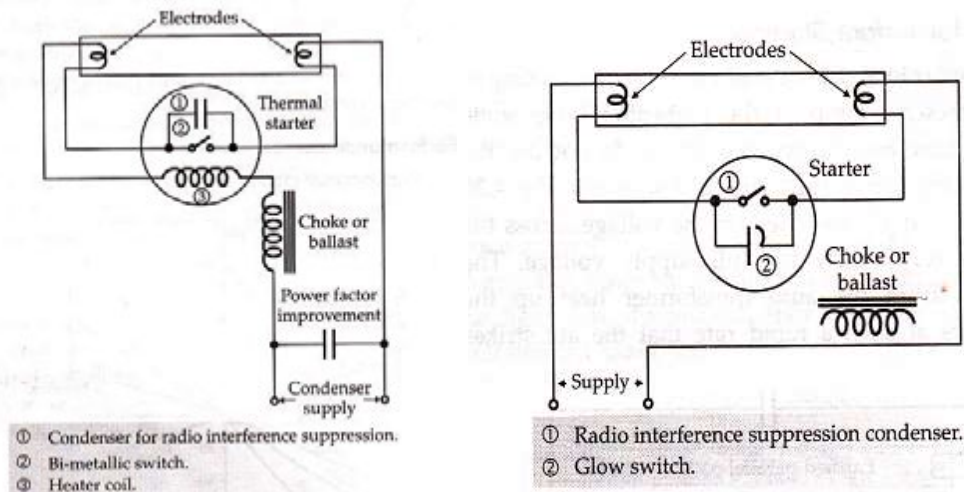

Fig.9 Fluorescent lamp

When the normal voltage is applied to the lamp, a glow discharge takes place across the glow switch and small current flows through the electrodes. The bimetallic strip expands due to the heating effect of the current in the glow discharge. The expansion of bimetallic strip causes the electrodes touch each other and the electrodes get pre heated due to flow of an appreciable amount of current. Mean while the bimetal cools. The glow switch opens and the resultant high voltage transient starts the arc discharge through the tube.

## CHAPTER-5

# INDUSTRIAL DRIVES

---

### Introduction

Electrical energy is finding increasing application in industrial and commercial fields. Electric drive for industrial purposes is now almost universal. There are number of inherent advantages that the electric drive possesses over other forms of conventional drives. It is cleaner, more easily controllable and more flexible. With greater advancement in the development of Electric motors and control gear, the trend in the industry is towards an all-electric drive.

Both d.c. And a.c. is used for electric drives. Use of d.c. is limited on account of permissible voltage drop in feeders. But d.c. systems are still in use for many reasons.

The electric drive due to various inherent advantages has been universally adopted by the industry. Both A.C. and D.C. motors are used, however, A.C. system is preferred. The utilization of electrical energy is always advantageous as it is cheaper, it can be easily transmitted at comparatively low line losses it is easy to maintain the voltage at consumer premises within the prescribed limits and it is possible to increase or decrease the voltage without appreciable loss of power.

In spite of the advantages of A.C. system, following are the applications of D.C. Industrial drives:

- (i) For traction purposes, as in such application a very high starting torque is required. The starting torque can be obtained from D.C. series motor at low operating cost.
- (ii) The speed of A.C. motors is almost constant, where as it can be varied easily in case of D.C. motor. Thus, for variable speed applications such as lift and Ward Leonard system etc., the D.C. motors are preferred.
- (iii) D.C. motors are also used in industry where very high accuracy of speed control is required.
- (iv) The cost of change-over from d.c. to a.c. involves changes both in the power system and the consumer's equipment and is likely to be expensive.
- (v) In some processes, Example: - electro-chemical, battery-charging etc. d.c. is the only type of power that is suitable.

### **Group Drive**

Where a number of machines are driven through belts from a common shaft, it is known as *group drive*. Alternatively, each machine may have its own driving motor, in which case it is called *individual drive*.

In group drive case, one motor is used as a drive for two or more machines. The motor is connected to a long shaft. The machines are connected to this shaft through belt and pulleys. The use of this kind of drive is restricted due to the following reasons:

- (i) If at certain instance all the machines are not in operation, then the motor will be working at low capacity.
- (ii) In case of fault in the motor all the machines connected to this motor will cease to operate thereby paralyzing either complete or part of industry up till the time the fault is removed.
- (iii) It is not possible to install any machine at a distant place.
- (iv) The possibility of installation of additional machines in an existing industry is limited.

However, there are certain advantages of the group drive, which are detailed below:

- i. Initial cost of installing the industry is low. For example, if the power requirement of each machine is 10 H.P. and there are 10 machines in the group, then the cost of ten numbers 10 H.P. motors will be much more than one 100 H.P. motor. Further, it is learnt from practical experience that the combined requirement of all these ten machines at a time will be less than 100 H.P. This further reduces the initial cost.
- ii. In certain industrial processes one process is connected to another process and will be advantageous if all these interconnected processes are stopped simultaneously.

### **Individual drive :**

In this case there is a separate driving motor for each machines. Such a drive is very common in most of the industries. It has the following advantages :

- i) If there is a fault in one motor, the effect on the production or output of the industry will not be appreciable.
- ii) Machines can be located at convenient places.
- iii) Continuity in the production of the industry is ensured to a higher degree.

Following is the disadvantage:

- i) Initial cost will be high.

### **Selection of Motors :**

Due to the universal adoption of electric drive, it has become necessary for the manufacturer to manufacture motors of various designs according to the suitability and use in various classes of industry. This has resulted into numerous types of motors. For this reason, the selection of motor itself has become an important and tedious process. Taking into account the conditions under which a motor is required to operate, following factors will decide the type of motor required. :

1. **Electrical Characteristics:** The following are the electrical characteristics:

- a. Starting characteristics
- b. Running characteristics
- c. Speed control
- d. Braking

2. Mechanical Characteristics. These are:

- a. Structural feature i.e. type of enclosure and bearing.
- b. Method employed for transmission of power.
- c. Noise.
- d. Type of cooling.

3. **Size and Rating of motors.**

Following are the sub-heads under these characteristics;

- a. Rating of the motor.
- b. Suitability of the motor for continuous intermittent or variable loads.
- c. Over load capacity.

4. Cost:

- a. Initial cost.
- b. Running cost.

In addition to the above factors, the type of current is also to be taken into consideration. From above it will be seen that the basic problem is to study carefully and thoroughly the load requirement, its surrounding and type of job it has to perform and then a motor which has the required characteristics and fulfil all the requirements is selected. The factors described above have been discussed in the following pages in detail.

### **Starting characteristics**

The starting torque exerted by a motor should be large enough to accelerate the motor and its load to the rated speed in a reasonably short time. Some motors may have to start against full load torque, Ex:- motors driving grinding mills or oil expellers. In the case of lifts and hoists, the motors have to start frequently with acceleration.

At the time of starting a motor two torques come into play: the torque required to overcome the static friction and the torque necessary to accelerate the motors and its load to the desired speed. The torques required for static friction cannot be easily determined. The torque for acceleration depends upon the load torque itself. The load torque may:

- (i) Increase with speed i.e., may be proportional to  $(\text{speed})^2$  as in the case of a fan or centrifugal pump OR
- (ii) Remain constant with speed as in the case of a hoist.



The starting gear should, therefore be able to carry the starting current taken by a motor to a safe value consistent with the production of the necessary starting torque.

### Starting Torque of DC Motors

Starting Torque in case of DC motors. Consider P poles motor producing flux  $\phi$  webers per pole and let,  $I_a$  be the total armature current. If the number of parallel paths are A, then the gross torque  $T_g$  is given as:

$$T_g = \frac{1}{2\pi} \times \frac{\phi Z P I_a}{A} \text{ m.Nw} = 0.159 \frac{\phi Z P I_a}{A} \text{ m.Nw} = 0.0162 \frac{\phi Z P I_a}{A} \text{ m.Kg}$$

Now, whole of this torque developed will not be available at the pulley or is not available for doing useful work, since some of the power (Torque) developed is utilized in supplying friction and windage losses. The difference of gross Torque and the Torque lost in friction is called the shaft torque.

Let,  $\omega$  be the angular speed of motor.

Power developed by the armature =  $T_g \omega$  metre-Newtons or joules or watts

$$= \frac{2\pi N T_g}{60}$$

But 1 H.P.(metric) = 735.5 watt

$$\therefore \text{H.P. (metric) developed by the armature} = \frac{2\pi N T_g}{60 \times 735.5}$$

The torque therefore, depends upon the product of flux and armature current and is independent of speed i.e. ,  $T \propto I_a$  .

In the case of a shunt motor, both the armature and the field are connected in parallel across constant voltage mains. The current taken by the field is, therefore, constant and hence the flux will be maintained constant so long as the field current remains constant. Therefore the torque in a shunt motor varies as the armature current. Full-load current will produce full-load torque and twice the full-load current will produce twice the full-load torque.

In the case of D.C. series motors, the current in the series winding and the armature is same. The flux is dependent directly on the value of the current the motor draws. Torque is, therefore, proportional to the square of the armature current i.e.  $T \propto I_a^2$  .The torque-current curve is, therefore, a parabola. But the flux varies as the current only upto the limit of saturation of the magnetic circuit and the torque current curve is parabolic in shape only up to the limit of saturation. Beyond the saturation point since " $\phi$ " "does not vary appreciably the torque current curve is almost a straight line. A d.c. series motor is, therefore suitable for drives starting with heavy loads, Ex- electric train, hoists and lifts etc.

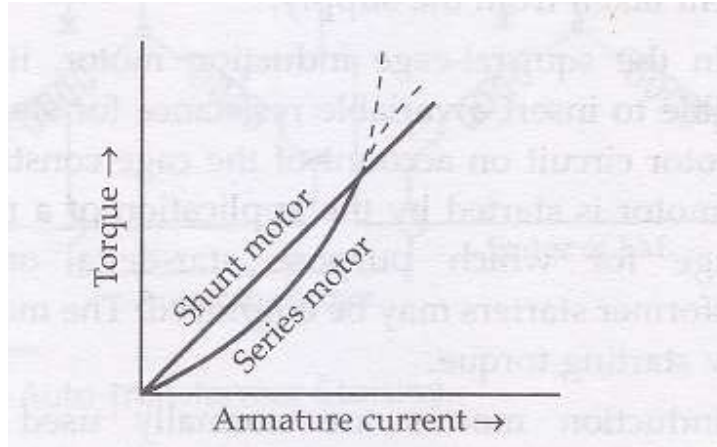

Fig..1 Torque Current characteristics of DC motor

### Three-Phase Induction motors

In a three-phase induction motor, if

$r_1$  = stator resistance per phase

$r'_2$  = rotor resistance per phase referred to the stator

$x_1$  = stator reactance per phase

$x'_2$  = rotor reactance per phase referred to the stator

$s$  = slip

$V$  = stator applied voltage per phase,

Then the torque,  $T$ , is given by

$$T = k \frac{V^2 r'_2 / s}{(r_1 + \frac{r'_2}{s})^2 + (x_1 + x'_2)^2} \quad \text{and}$$

$$\text{Stator current per phase is: } I = \frac{V}{\sqrt{(r_1 + \frac{r'_2}{s})^2 + (x_1 + x'_2)^2}}$$

If  $k$  is made unity, the torque is expressed in synchronous watts per phase.

At starting,

$$s = 1$$

Therefore, starting Torque,

$$T_s = \frac{V^2 r'_2}{(r_1 + r'_2)^2 + (x_1 + x'_2)^2} \quad \text{synchronous watts per phase}$$

and starting current per phase

$$I_s = \frac{V}{\sqrt{(r_1 + r'_2)^2 + (x_1 + x'_2)^2}} \quad \text{amperes.}$$

The starting torque is a maximum if the rotor resistance per phase is made equal to its leakage reactance. It is, therefore, usual to start a slip ring induction motor with a variable resistance in its rotor circuit to have a good starting torque and to cut the resistance in steps as the motor speeds up. The resistance in the rotor circuit also serves the purpose of limiting the starting current taken from the supply.

In the squirrel cage induction motor, it is not possible to insert a variable resistance for starting in the rotor circuit on account of the cage construction. The motor is started by the application of a reduced voltage for which purpose star-delta or auto-transformer starters may be employed. The motor has a low starting torque

Induction motors are normally used where constant torque is required, ex- in paper machinery, textile machinery, compressors, conveyors etc. Squirrel cage motors are more reliable, cheaper and easier to use where as phase wound motors are expensive and maintenance is complicated. The former are used for low and medium H.P. while the latter are used for high H.P.

Motors with double cage have a high starting torque. The outer cage is made of high-resistance metal bars and inner cage is made of copper bars. The inductance of the inner winding is higher than that of the outer high resistance winding. At the instant of starting, the motor induced currents are at the line frequency and the inner cage has a high reactance ( $2\pi fL$ ) with the result that the rotor currents remain confined to the outer cage despite its high resistance. The starting torque is, therefore, high. During normal running, the reactance of the inner cage decreases ( $2\pi s fL$ ), and the rotor currents are now confined to the inner cage which is a low resistance winding. This gives a high efficiency of the motor.

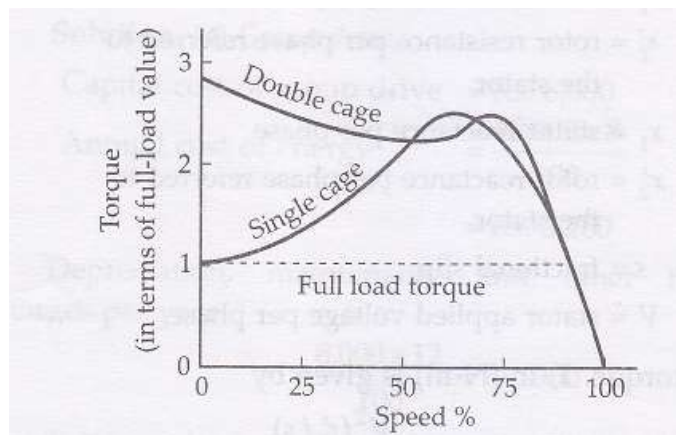

Fig.2 Torque speed characteristics of Induction motor

The Figure above shows the speed-torque curves of a single cage and double cage motor.

An important relation existing for three-phase induction motor, i. e.

$$\frac{\text{Starting Torque}}{\text{Full - Load torque}} = \left( \frac{\text{Starting Current}}{\text{Full - Load Current}} \right)^2 \times \text{Full Load slip}$$

$$i. e., \frac{T_s}{T_L} = \left( \frac{I_s}{I_L} \right)^2 \times s_{FL}$$

## Methods of starting 3-phase induction motors

It is desirable to start a.c. motors at full voltage to attain simplicity and economy in the starting gear. Induction motors can be designed and built to enable them to be started on full voltage. But in case of cage motors the starting current may be large enough to produce considerable voltage drop in the distribution system which may adversely affect other apparatus and also cause light flicker.

Induction Motors are therefore, started on reduced voltage. The various methods of starting are discussed as follows:

### 1. Resistor starting method

A series resistor is used in each line and may be arranged in a manner that the resistance is reduced to zero in steps so that the motor current may increase to the full value gradually and transients are avoided.

The torque efficiency which is

$$\frac{\text{Torque developed by the Motor/ Full load torque}}{\text{Current of Motor / Full load current}}$$

A motor having a starting torque equal to twice the full-load torque and a starting current six times the full load current has a torque efficiency =  $2/6=0.33$ .

If the same motor is started at 60 percent voltage by using resistors, the line current will be  $(0.6 \times 6 \times \text{full-load current})$  and the starting torque will be  $[0.6 \times 0.6 \times 2 \times \text{full-load torque}]$ . The Torque efficiency will be  $(0.6 \times 0.6 \times 2)/0.6 \times 6 = 0.2$  .

### 2. Reactor starting

It is not a frequently employed as resistors or auto transformer starting, though the method is similar to resistor starting. The acceleration is very smooth in this case though the acceleration time is comparatively longer.

### 3. Autotransformer starting

Taps are provided on the auto transformer so that the motor can be started at reduced voltage. Taps are for 50, 65 and 80 percent of line voltage; the 50 percent tap being provided only in the case of sizes above 50 H.P. In the second method of operation the large transient current is reduced since the motor is always connected through the auto-transformer winding to the line.

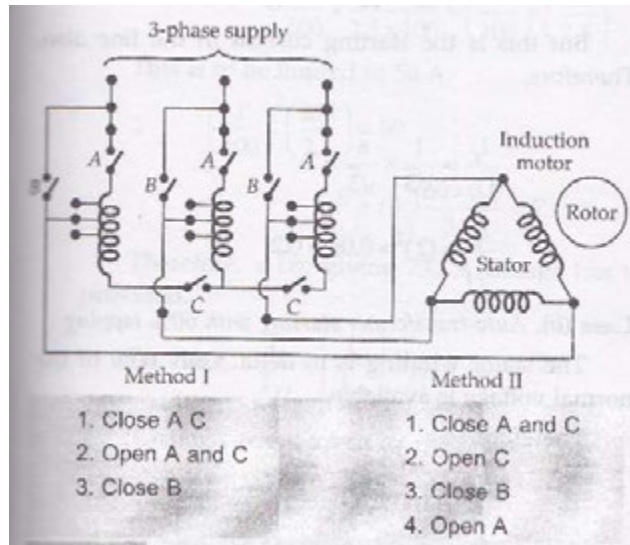

Fig. 3. Starting of SQIM by Autotransformer starter

We can determine the reduction in the starting current when using auto-transformer starter. Consider an auto-transformer with a transformation ratio  $K = \frac{\text{Primary Voltage}}{\text{Secondary voltage}}$ . Consider also that the motor has a starting torque equal to twice full-load torque and starting current equal to six times the full load current. If the motor is started at full voltage, phase voltage  $E_{ph} = E/\sqrt{3}$  and starting current =  $6I$ . when the motor is started through an auto-transformer, the phase voltage is  $E_{ph}/k$  and the starting current =  $6I/k$ .

Also we have  $\frac{E_{ph}}{V_{ph}} = k = \frac{N_1}{N_2} = \frac{I_2}{I_1}$

Where  $N_1$  =No. of primary turns

$N_2$  =No. of secondary turns

$I_1$  = primary current

$I_2$  = secondary current

$I_2 = 6I/k = kI_1$  or  $I_1 = (6/k)^2 I$ .

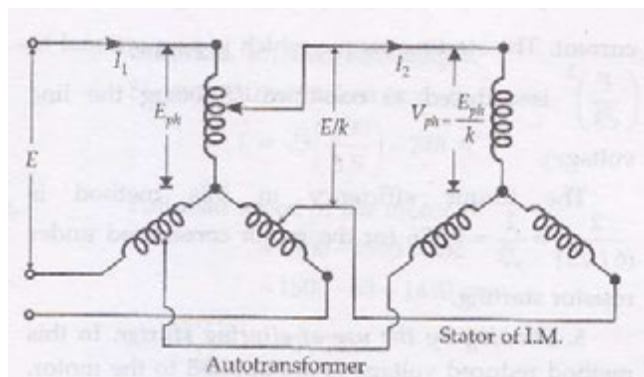

Fig.4 Autotransformer starting principle

Therefore, the line current is reduced inversely as the square of the ratio of transformation. Since the torque is proportional to the square of the applied voltage, the starting torque is proportional to  $V_{ph}^2$  or  $(E_{ph}/k)^2$ . If T is the full voltage starting torque, starting torque at reduced voltage =  $T/k^2$ .

$$\text{The torque efficiency} = 2/(6/k)^2 = 0.33 k^2$$

#### 4. Star-delta starting

The stator of the cage motor is connected in star in the starting position and in delta in the running position, so that  $\frac{1}{\sqrt{3}}$  of the line voltage is impressed on each phase at the time of starting. A star-delta starter is shown schematically in figure 5, The starting line current of the motor with star-delta starter is also reduced to  $\frac{1}{\sqrt{3}}$  full voltage starting line current. The starting torque, which is proportional to  $(\frac{E}{\sqrt{3}})^2$  is reduced to one-third. (Where E is the line voltage).

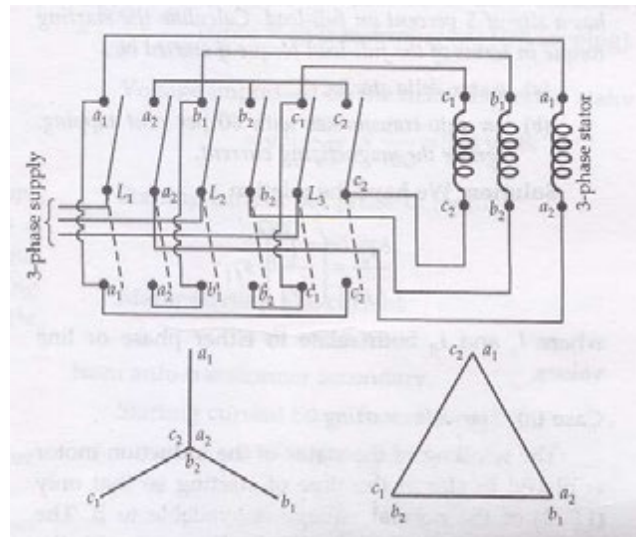

Fig..5. Star delta starting

The torque efficiency in this method is  $\frac{2}{6/\sqrt{3}} = \frac{1}{\sqrt{3}} = 0.576$  for the motor considered under resistor starting.

#### 5. Starting by the use of slip-ring starter :

In this method reduced voltage is not applied to the motor. The full voltage is applied to the stator but resistance is inserted in each phase of the wound rotor. Since the stator and rotor can be regarded as the primary and secondary of a transformer, the resistors in the secondary limit the currents in the rotor winding and since in a transformer  $\frac{I_1}{I_2} = \frac{V_2}{V_1}$ , the stator current  $I_1$  is also reduced.

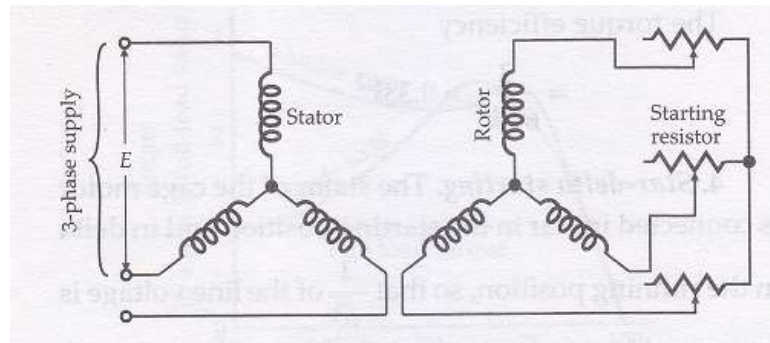

Fig.6. Rotor resistance starter

### Limitation of size

From the foregoing examples, it is seen that the starting torque in case of cage motor varies with the type of starting method employed. In fact, the starting difficulty of cage-type motors has limited their application to loads requiring not more than about 40 or 50 HP with not more than about 50 percent full-load torque. The slip-ring motor is used beyond this limit.

Next, discussion in brief about the starting of other type of motors.

### 1.4. Single-Phase Induction Motors

A single-phase induction motor does not have a rotating magnetic field. It has only a pulsating field and therefore does not possess any starting torque. The following three methods are employed to make the motor self-starting.

- (a) **Pole-shading:** The motor is of squirrel-cage type and the stator pole is shaded by a heavy copper wire or strip. The current induced in the shading coil causes the magnetic field through the shaded portion of the pole face to lag behind the main flux thereby producing a rotating Magnetic field. Such motors have a low starting torque but are quite economical in small sizes.
- (b) **Phase-splitting:** A two-phase supply is obtained from a single-phase line by using a capacitor. The motor has a cage-rotor and a stator containing two separate windings located in the same manner as for a two-phase stator. One of the windings is connected directly to supply and the other through the capacitor. A rotating magnetic field is obtained in the air-gap. There are two types of capacitor motors: the capacitor start motor, in which case the capacitor is in circuit only during the starting period and is disconnected at a predetermined speed by a centrifugal switch; the other type is the capacitor start and run motor where the capacitor is connected permanently and improves the power factor of the motor.

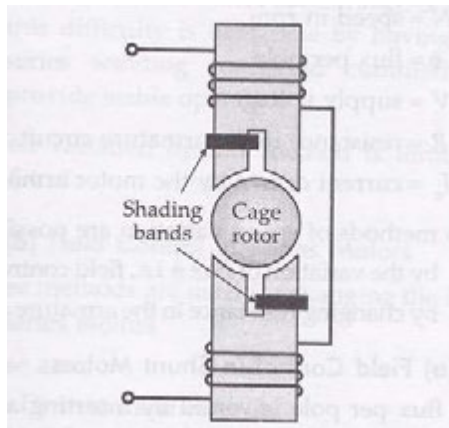

Fig..7 Shaded pole motor

- (c) **Repulsion motor starting:** the rotor has a repulsion motor winding and therefore starts as a repulsion motor giving high starting torque. As it runs to speed a centrifugal device short-circuits the commutator bars and lifts the brushes, converting the motor into a plain squirrel cage one.

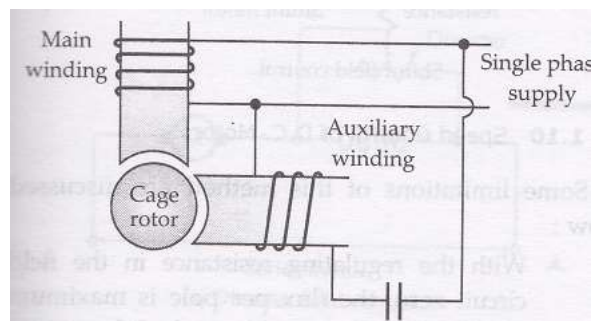

Fig..8 Split phase starting

- (d) **Synchronous motors:** There is no starting torque in a synchronous motor. It has to be run up to synchronous speed by another motor and synchronized to the supply. To make it self-starting a cage winding is provided on the poles. It starts as a plain squirrel cage motor and when it has attained nearly synchronous speed at no-load, the d.c excitation is switched on and the rotor pulls into synchronism. Starting torque between 50 to 100 percent full load torque can be obtained with twice full load current. The synchronous Induction motor has a cylindrical rotor with a slip-ring induction motor winding. It starts as a slip-ring induction motor with good starting torque and when it has almost reached the synchronous speed, d.c. is passed through the rotor winding making rotor pull into synchronism.



## Running Characteristics

The running characteristics of a motor include the speed-torque or the speed-current characteristics, losses, efficiency and power factor at various loads. Power factor consideration crops up in the case of a.c. motors only.

### D.C. Motor

In the case of DC shunt motors speed is fairly constant with load; there is only a slight fall in speed as the load comes up. The speed torque characteristic is a slightly drooping straight line.

For the DC series motor the speed is normally high at low loads and decreases as the motor is loaded. The speed –Torque characteristics is a supply drooping curve.

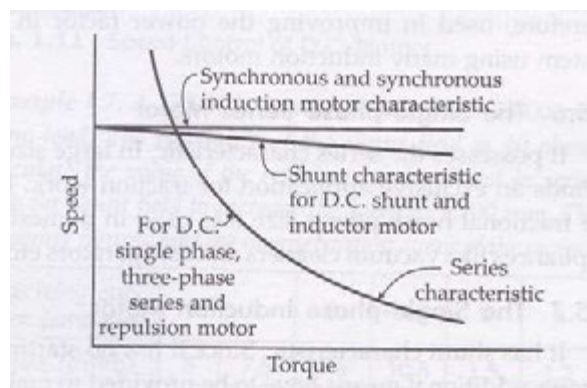

Fig.9 Torque speed relation of dc and ac motors

In the compound motor, the speed-torque characteristics may be made to lie anywhere between the pure shunt and the pure series by suitably adjusting the series and the windings.

### The Three-phase Induction Motors

It possesses shunt characteristics. The power factor is very poor at low loads but improves as the load increases. The power factor, however, always remains less than unity.

### The Synchronous and synchronous-Induction motor

The synchronous motor is a constant speed motor: The speed is fixed by the frequency of the supply. It is not, however, self-starting. It is started by an auxiliary motor and synchronized to the supply. This disadvantage is eliminated in a synchronous-Induction Motor where the machine starts as plain Induction motor and when the speed is very near the synchronous speed the DC excitation to the rotor is switched on and the motor pull into synchronism.

By varying the field excitation of these types of motors the power factor may be made unity or even be made leading. An over-excited synchronous motor works as a leading power factor while an under-excited motor works as lagging power factor. It is, therefore used in improving the power factor in a system using many induction motors.

### Single-phase series motor

It possesses the series characteristics. In large sizes, it finds an exclusive application of Traction work. In fractional horse power size, it is used in domestic appliances like vacuum cleaners and refrigerators etc.

### Single-phase Induction motor

It has shunt characteristics. Since it has no starting torque, additional means have to be provided to make it starting. Repulsion start and the capacitor start motor are the common modifications of the single-phase induction motor.

### Repulsion motor

It has series characteristics and closely resembles the series motor in construction. The armature is short circuited in itself.

### SPEED CONTROL:

Control of speed for an industrial drive depends upon the nature of work being carried out. A certain operation may require a continuously varying speed; another one may only require two fixed speeds. Sometimes creeping speed may be necessary to adjust the work. For most industrial drives, however, a control speed within  $\pm 20$  per cent may be suitable

### Speed control of D.C. motors:

The speed of D.C. motors is given by the expression

$$E = \frac{NP\phi Z}{60A}$$

$$N = \frac{E \cdot 60A}{P\phi Z} \text{ where } E = V - I_a R$$

$$N = K \frac{V - I_a R}{\phi} \text{ where } K = \frac{60A}{PZ}$$

Where, N = speed in rpm

$\phi$  = flux/pole

V = supply voltage

R = resistance in the armature circuit

$I_a$  = current drawn by the motor armature

Two methods of speed variations are possible:

1. Flux variation or field control
2. By changing resistance in the armature circuit

### Field control in shunt motors

The flux per pole is varied by inserting an extra resistance in the field circuit. Variation of the flux per pole changes the speed of the motor.

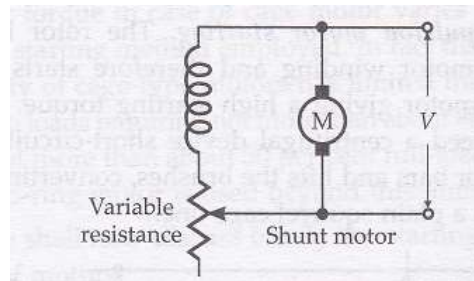

Fig.10 Shunt Field Control

*Some limitations of this method are discussed below:*

- i. With the regulating resistance in the field circuit zero, the flux per pole, is maximum which gives the lowest speed of the motor. Motors are usually designed to work at a speed slightly less than the rated speed when the regulating resistance is zero. It is obvious that any lower speed than this cannot be achieved by this method.
- ii. The speed of the motor  $N$  is proportional to  $V - I_a R / \phi$  where as the full-load torque  $T$  is proportional to  $T N$  or  $V I_a$  which is constant. Therefore, this method can be utilized only where the horse power of the load remains constant.
- iii. There is a limit to which the field can be weakened to obtain high speed. At such a speed the motor will tend to draw large current to develop the same torque. But this will result in the main field ampere-turns becoming much smaller than the armature mmf. The armature reaction will demagnetize and distort the main flux making the operation of the motor unstable. In motors where a wide speed-range is required, this difficulty is overcome by having a light series winding connected cumulatively to provide stable operation.

Speed variation by this method is limited to a ratio of 5:1.

### Field control in series motors

Three methods are used for changing the flux per pole in series motors

These are:

- Diverter field control

- Tapped field control
- Series-parallel field control

i. **Diverter Field control :**

A shunt is employed in parallel with the series field to divert a part of the current in the series field thus causing field weakening. Speeds higher than normal are attained when the diverter is used.

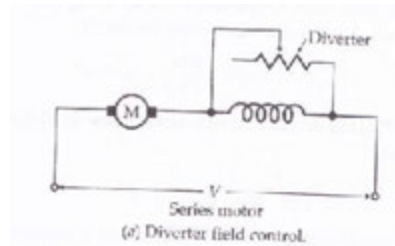

Fig.11 Field diverter control

**Tapped Field control:**

Tapping are provided on the field winding and current may be passed through different number of turns there by changing the field ampere-turns. This method is commonly used for series motors used in traction work.

**Series-Parallel Field control:**

The field winding is designed in two sections which may either be connected in series or in parallel. The field ampere-turns are reduced to half the value in parallel connection as compared to those in series connection. The speed, therefore, becomes about twice the initial value. Though the method is simple and inexpensive, only two speeds are possible.

**CONTROL OF SPEED BY CHANGE OF SERIES RESISTANCE IN THE ARMATURE CIRCUIT**

Since  $N \propto \frac{V - I_a R}{\phi}$ , the speed of a D.C. motor can be changed by varying R, resistance in the armature circuit. The torque of a motor is proportional to the product of the flux,  $\phi$  and the armature current  $I_a$ . In the case of a shunt motor, since  $\phi$  is constant, N will be proportional to  $V - I_a R$ . if constant torque is required  $I_a$  should remain unchanged. But since speed is to be varied R has to be varied. Increase of R (for constant torque and therefore constant armature current) will give decreasing values of speed. The minimum value of R is  $R_a$ , the resistance of the armature itself. The figure shows the armature speed torque characteristics.

$$R = r + R_a$$

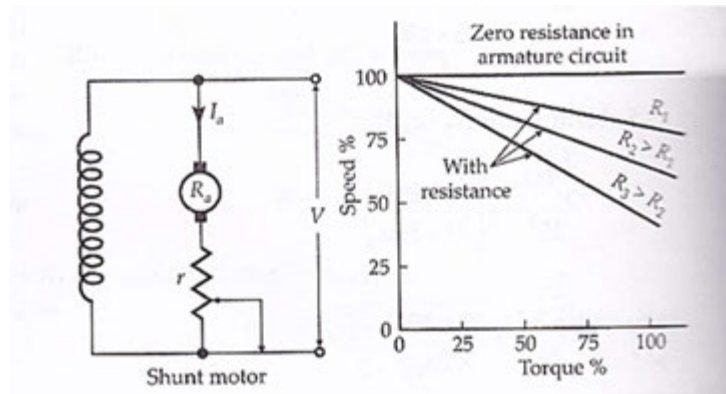

Fig.12 Speed control of shunt motor taking series resistance in armature

For a theoretical value of  $R = 0$ , the horizontal straight line passing through 100% speed ordinate is the limiting value. For any other values of  $R$  which may be  $R_1 = r_1 + R_a$  or  $R_2 = r_2 + R_a$ ,  $R_2 > R_1$  or  $R_3 = r_3 + R_a$ ,  $R_3 > R_2$  etc. the curves are as shown.

If this method is used for a load requiring constant torque at all speeds, the armature current must remain constant and so the input to the motor (i.e., armature) is also constant. But the output decreases with the decrease in speed and hence the efficiency of the motor is poor at lower speeds. The power loss takes place in the controlling resistance  $r$ . In the case of fans and centrifugal pumps where the load torque decreases at lower speeds, this method may be quite convenient and economical for short periods. Creeping speeds may also be obtained by this method.

In a series motor, an increase in the armature circuit resistance will decrease both speed and torque. Since the flux is dependent on the armature current the torque is proportional to  $I$ . For a constant torque if different speeds are required, current ( $I$ ) has to be constant which will make  $\phi$  constant. For reducing the speed resistance is to be increased.

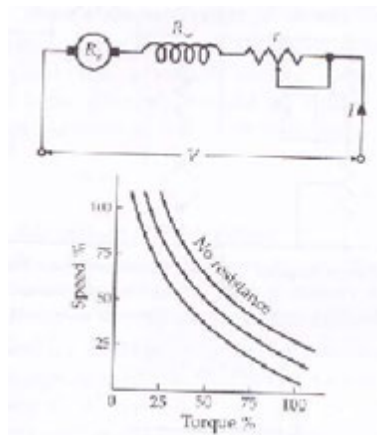

Fig.13 Speed control of series motor with series resistance in armature

### Control of Motor Speed by Shunting the Armature by a Resistance

The arrangement of varying the speed of a d.c. motor by changing the series resistance in the armature circuit is at times not applicable as the speed of the motor rises if the load is reduced. We can see from the equation  $N \propto (V - I_a R) / \phi$  that as  $I_a$  diminishes  $N$  increases. To eliminate this drawback, the armature is shunted by a variable resistance. A series resistance is also used as shown in fig. 14. By adjusting  $P$  and  $Q$  a number of speed torque curves can be obtained.

If we apply Thevenin's Theorem to the circuit in fig.14, we get  $P$  and  $Q$  in parallel i.e., short circuit resistance  $R_{sh}$  by short-circuiting the source of supply and removing the branch (i.e., armature) through which we wish to find the value of the current flowing. Therefore, the open circuit voltage across the armature is  $V_{oc} = \{P / (P+Q)\} V$ . Fig.14 shows the equivalent circuit based on Thevenin's Theorem. The current is given by

$$I = V_{oc} / R_a + R_{sh} \text{ Where } V_{oc} = P / (P+Q) V \text{ and } R_{sh} = PQ / P+Q = \text{short circuit resistance.}$$

The efficiency of this method is poor and heavy currents may be drawn from the supply at certain speeds.

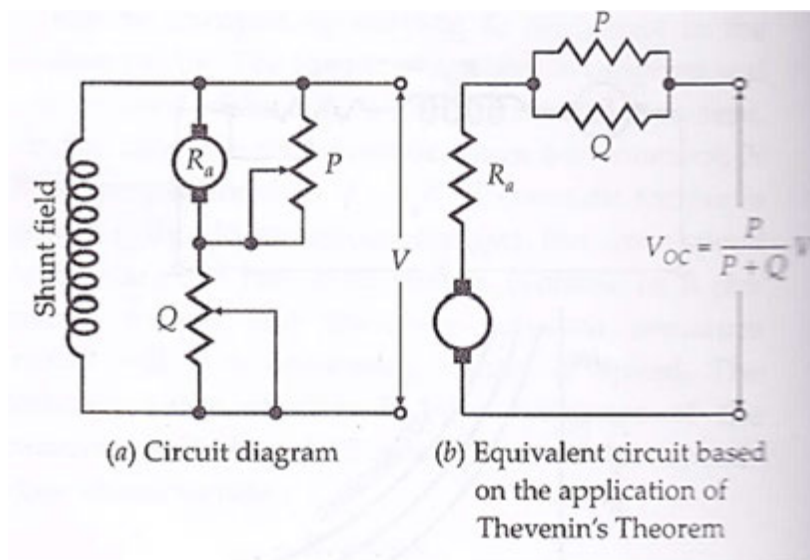

Fig. 14. Controlling resistance in parallel arrangement

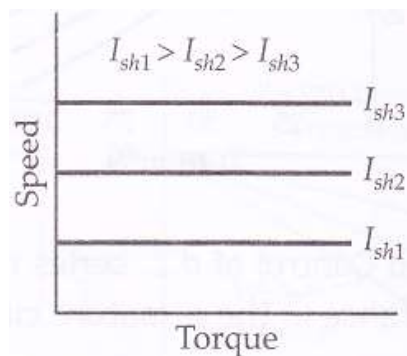

Fig. 15 Speed Torque characteristics

## Booster Control

In Figure 16,  $M_1$  is the main motor used for driving the load. It is excited from constant d.c. supply.  $B$  is the separately excited booster whose voltage and polarity can be controlled by the booster field  $BF$ . With the arrangement of tapping the voltage from the parallel resistances the current through the booster field can be reversed which reverses the polarity of the booster armature voltage. Thus, necessary boost or buck can be provided to  $M_1$ .  $M_2$  is the shunt motor which drives the booster armature. The speed can be varied over a wide range depending on the size of the booster. This method is, however, suitable for small motors; otherwise the size of the booster becomes uneconomical.

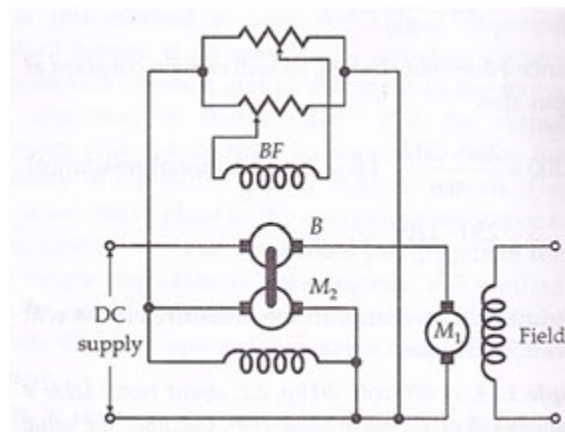

Fig.16 Booster control

## Ward-Leonard System of Speed Control

In this method, the current in the motor armature is supplied from a variable voltage source, say a special motor generator set and the field is given a constant excitation so that in the expression

$$N = K \frac{V - I_a R}{\phi}$$

Where  $V$  is variable and  $\phi$  is constant.

This system is used where a very fine speed control is needed as in the case of colliery winders. Fig. 17 shows the application of this method.

There is a motor generator set whose motor  $M$  is a 3-phase slip ring induction machine coupled to the d.c. generator  $G$ . A flywheel is mounted on the motor generator shaft to equalize the fluctuations in the load. A d.c. exciter is also coupled to the M.G. set. This exciter supplies the excitations to the generator  $G$  and the load motor. In order to equalize the fluctuations in the load the flywheel must decelerate during the lean load period. This is achieved with the help of the torque motor which puts extra resistance in the slip-ring rotor by operating the liquid rheostat when peak load comes on. The torque-motor is supplied through the  $CT_s$  as shown and is actuated by current proportional to that drawn by the motor of the M.G. set. When slip-ring motor tends to draw heavier current, the torque-motor is actuated through the  $CT_s$  increasing the resistance of the liquid rheostat which decreases the speed of the M.G. set and allows the flywheel to give up a part of its stored energy. The whole process is reversed when the

load decreases. The direction of the load motor can be reversed by reversing the polarity of the voltage supplied to it by the generator G. The polarity of generator voltage can be changed through the reversing switch which reverses the excitation of the generator. The Ward Leonard Control with a flywheel is known as Ward-Leonard-Ilgner Control.

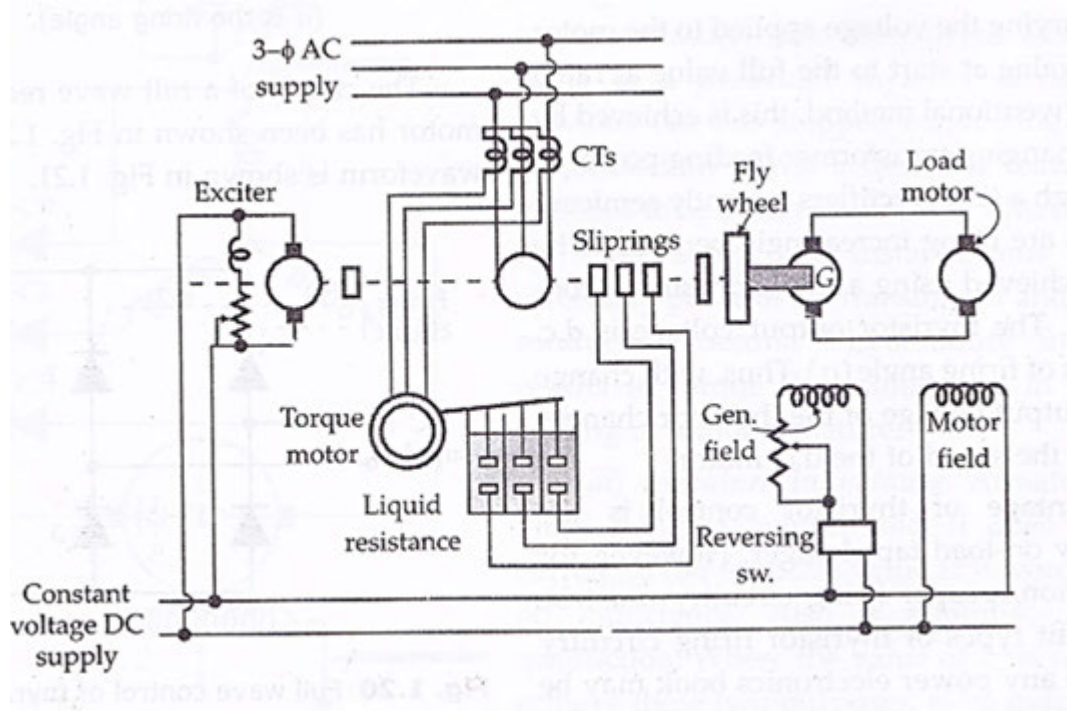

Fig. 17 Ward Leonard Ilgner control

## SPEED CONTROL OF INDUCTION MOTORS

Speed control of Induction motor is given by the following equation:

$$N_r = N_s(1-s) = \frac{120f}{P}(1-s)$$

$$[N_s = \text{synchronous speed} = 120f/P]$$

Thus, the speed of an induction motor, broadly speaking, can be regulated by three methods i.e. by varying any of the above quantities Viz. frequency, number of poles, slip.

Thus speed change can be achieved by varying the frequency. Induction motor has drawbacks of developing low starting torque, drawing heavy starting current and having no easy means of continuous easy speed control. On the other hand, assets of induction motor are: trouble free operation, less maintenance, high voltage operation consequently needing reduced amount of current and automatic regeneration. In addition to these, because of extreme mechanical simplicity in the construction, the rotor can resist centrifugal forces better than D.C. armature and therefore, for a given amount of iron and copper, more power can be produced.

## FREQUENCY METHOD OF SPEED CONTROL

The above equation suggests that the speed of a induction motor is directly proportional to the frequency of supply voltage.



### Control from variable frequency supply

Induction motor operates at a high efficiency and power factor at speeds near to its synchronous speed. The difference between actual speed and synchronous speed, which is called slip, represents losses in the rotor. Thus, in induction motor, operating from constant frequency supply, slip has to be small if efficiency is to be high. In other words, motor should operate at high speed (near synchronous speed). If, however, synchronous speed itself is brought down near to actual slow operating speed, motor will still be working at high efficiency. This is achieved in variable frequency supply. Another advantage of feeding low frequency supply to induction motor at starting is that it does not take heavy starting current. This is proved as follows:

If suitable variable frequency supply is made available, induction motor can develop high starting torque without excessive rotor currents when it is supplied with low frequency voltage supply say  $\frac{1}{2}$  to 9 cycles. Intersection of the stable region of torque speed curve with the load torque curve gives the operating speed. As the frequency of supply is reduced, torque curve shown dotted will move more towards left. This increases the starting torque ( $T_s$ ). Another advantage of variable frequency supply is that as the motor speed falls, the frequency of supply is reduced.

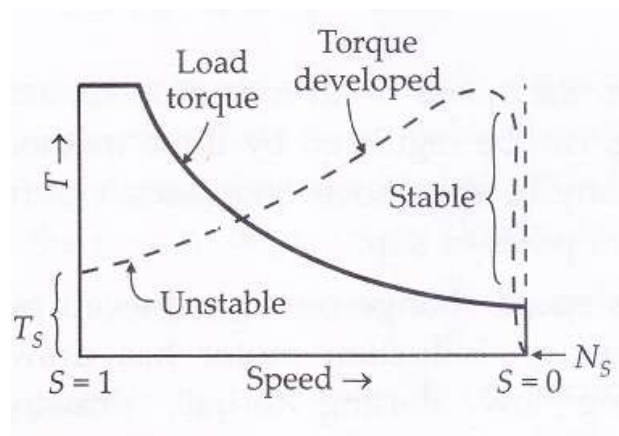

Fig.18 Electromagnetic torque and load torque profile

This avoids the operation of motor on unstable portion of the speed torque curve. Induction motors apart from the advantage of avoiding commutator maintenance, can be of smaller size as they can be robust higher speeds and higher temperatures than D.C. motors and in addition they are more efficient. Induction motor is excellent for the industrial purpose as it has excellent power weight ratio, great mechanical strength, suitability for higher speeds, no sliding contacts and high starting torque without overload. But all these advantages are available only through close control of flux and frequency.

### Control by Variable Frequency Inverter Employing Thyristor.

With a conventional rotary converter, it was not possible to obtain low frequencies, so that attempt for developing high starting torque always resulted in heavy rotor currents. However, with the development of silicon controlled rectifier (SCR), used as inverter, the frequency of three phase supply can be adjusted.

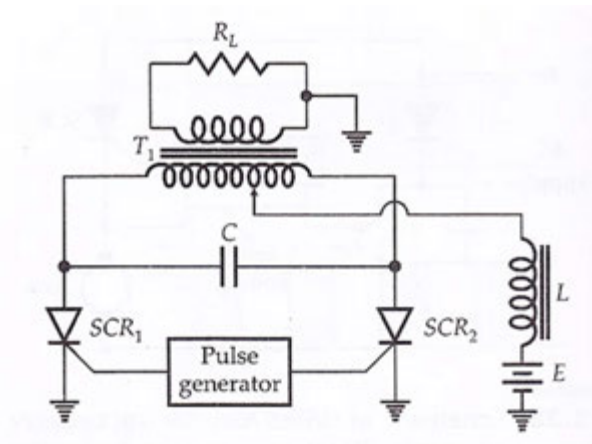

Fig. 19 Schematic of variable frequency inverter

Fig. 19 shows a single phase parallel inverter circuit using two SCRs. To start with, assume SCR<sub>1</sub> as conducting and SCR<sub>2</sub> as off. Left plate of condenser C will be at negative potential and right plate will be at positive potential at double the voltage of D.C. source due to auto transformer action. A trigger from the pulse generator to SCR<sub>2</sub> will switch it on. Now condenser C will send current through SCR<sub>2</sub> and block SCR<sub>1</sub>. D.C. source will send current through inductance L, transformer T and SCR<sub>2</sub>. Current pulse flowing through transformer will produce polarity in the secondary of transformer of opposite sign to that produced previously when SCR<sub>1</sub> was conducting. Condenser C will now be charged with right hand plate negative and left hand plate positive to double the D.C. source voltage. Now when SCR<sub>1</sub> is triggered, condenser C will again discharge but this time through SCR<sub>1</sub> to block SCR<sub>2</sub>. In this way cycle repeats. For 1:1 turn ratio of transformer, the peak value of A.C. square wave is half the voltage of d.c. source and frequency of a.c. supply depends upon the frequency of the firing of SCRs.

### Pole Changing Method of Speed Control

This method is applicable to squirrel cage motors only, as their rotors can adjust themselves to any number of poles. This method of speed control is used for driving drilling machines which require different speeds for drilling into different metals. This is also used for lifts where regenerative braking can be applied by pole changing. On increasing the number of poles synchronous speed becomes less than the actual running speed and motor now works as an induction generator. Some motors have two stator windings, wound for different poles.

### By Applying Variable Voltage to Stator

In Fig. 20, two speed-torque curves of a motor with different applied voltages are shown. Torque developed is proportional to square of applied voltage. Hence speed-torque curve 'A' will be for higher voltage and 'B' for lower voltage. Intersection of load torque line with the torque developed, gives us speed ( $N_1$ ) with higher voltage applied and  $N_2$  speed with lower voltage applied. With constant torque loads, speed control by this method gives limited variation of speed. However, for loads whose torque varies as the square of speed, this method gives wide range of speed.

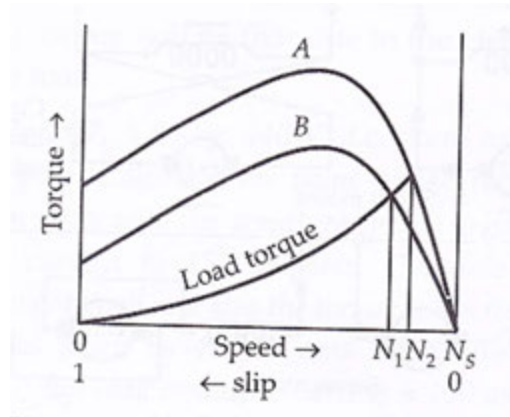

Fig.20 Torque speed characteristics with voltage

### **By Varying the Rotor Copper Losses**

For constant load torque applications, slip is directly proportional to the rotor copper losses in induction motor. By increasing the rotor copper losses, slip will be increased and hence speed can be decreased. Rotor losses can be regulated by following methods.

#### **1. By Inserting External Resistance in the Rotor Circuit.**

In induction motor, for a given torque to be developed, rotor current remains constant. Therefore, if resistance is inserted in the rotor circuit, it will increase the rotor copper losses and, therefore, slip. This method, besides being wasteful for low speeds, requires heavy three phase controller to dissipate the losses.

2. **By Cascade Control.** Instead of wasting the energy in rotor resistance and creating a problem of disposal of heat, it can be taken out of the rotor and fed to another motor which is capable of taking power at low frequency. This motor is usually mechanically coupled to the main motor. Thus power taken from the rotor is converted to mechanical energy. This arrangement would give increased torque output at reduced speed. This rotor power at low frequency can also be converted to power at supply frequency by means of frequency converter and fed back to line. Arrangement of connecting auxiliary machine to the rotor of main motor to perform any of the above functions is called cascading.

### **Speed Control by Slip Coupling**

This method allows driver shaft to run faster than the driven shaft by an amount which can be controlled. There will be some power loss in the coupling itself. One form of slip coupling consists of stator and rotor. Rotor is squirrel cage type and is keyed to the driven. Around the rotor is stator containing d.c. excited salient poles. Stator is keyed to the driver. In ordinary induction motor rotating magnetic field is produced electrically by the three phase currents. As against this, in slip coupling, magnetic field is mechanically driven by the driver. This will exert torque on the rotor which will be transmitted to the driven. In induction motor the magnitude of the torque is dependent upon the

magnitude of the rotating field or applied voltage. In slip coupling, also the magnitude of the torque at which slip occurs can be varied by the excitation of the slip coupling which is conveyed to it through two slip rings. Torque slip characteristic of slip coupling is essentially same as that of induction motor. Slip coupling can, therefore, make it possible to have variable speed drive from constant speed driver.

## ELECTRIC BRAKING

In many industrial drives, it becomes important to stop motor and its work in a reasonably short time, as in the case of planer where the tool must be stopped quickly at the end of its stroke. To achieve this breaking system has to be used.

Two types of breaking systems are possible:

1. Mechanical or friction braking where the motor is stopped by using a brake shoe or band on brake drum.
2. Electrical braking where the kinetic energy of the motor and tool is converted to electrical energy and is dispatching a heat in a resistance or returned to the supply system.

Electric braking is superior to mechanical braking since it is much quicker and eliminates the cost of maintenance of mechanical brakes. However, in order to finally bring the motor so a standstill and hold it there, friction brakes are essential.

The following types of electric braking are employed:

1. Plugging
2. Rheostatic or dynamic braking
3. Regenerative braking

## PLUGGING

The connections of the armature are reversed so that the motor tends to rotate in the reverse direction thus providing the necessary braking effect. However, the supply must be cut off when the motor comes to rest otherwise it will start rotating in the reverse direction. Plugging may be employed with D.C. motor or induction motor and synchronous machines.

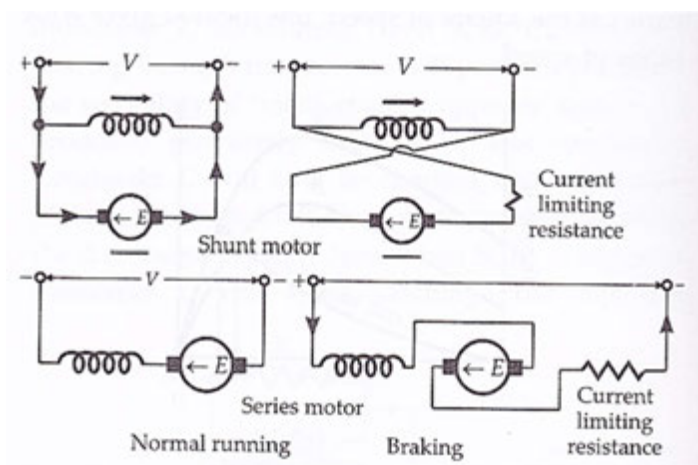

Fig.21 Plugging in DC motors

### **Plugging with D.C. motors**

(a) The armature connections are reversed with respect to the field so that the current in the armature reverse. During normal running the back emf  $E$  is opposite to the direction of the armature current but during braking the back emf  $E$  and the armature current are in the same direction. At the instant of reversal of armature connections, a voltage equal to  $V+E$  is impressed across the armature circuit,  $V$  being the supply voltage. Since  $E$  is very nearly equal to the  $V$ , the impressed voltage is approximately  $2V$ . This will cause a great rush of current in the armature circuit. To prevent this, the starting resistance is reinserted in the armature circuit as shown below.

It should, however, be noted that during braking, in addition to the kinetic energy of the motor being dissipated in the resistance, some energy is being drawn from the supply. There is, therefore, a waste of energy.

(b) If any two supply phases are interchanged with each other the direction of rotation of the magnetic field reverses and, therefore, the torque on the rotor also reverses providing a braking action. Supply, however, has to be cut off when the motor comes to rest, otherwise the rotor would start building up motion in reverse direction. The rotor and stator currents tend to be abnormally high and a resistance may have to be inserted in the rotor or stator circuit for the purpose of protection.

### **(c) PLUGGING WITH SYNCHRONOUS MOTORS**

If the D.C. excitation of the synchronous motor is reversed, the D.C. and A.C. fields will rotate in opposite direction and there can be no braking effect. But in case of motors fitted within damper windings the eddy currents induced in them provide braking.

### **Rheostatic or Dynamic Braking**

The motor is disconnected from the supply and worked as a generator driven by the kinetic energy of the rotor and the load. A resistance is connected across the motor terminals; the kinetic energy of rotation is converted into electrical energy and is dissipated in the resistance.

#### **(a) D.C. Motors-shunt**

The armature is disconnected from the supply and connected across a resistance. The motor now works as a separately excited generator and a braking torque is applied by the current delivered to the resistance. If, however, the supply fails, the braking action vanishes as the excitation disappears. This drawback is sometimes removed by fitting a series winding in the armature circuit which is connected during the braking period only. Due to the action of this winding, the motor self excites a series generator and the current delivered by the armature provides braking action.

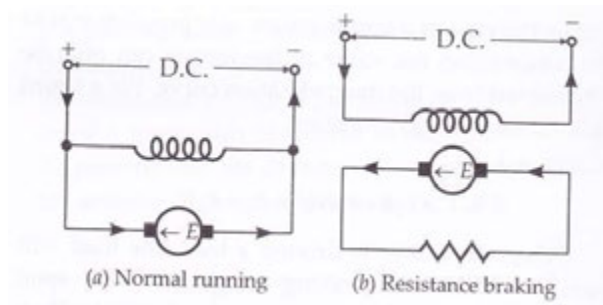

Fig..22 Rheostatic braking of shunt motor

(b) Series D.C. Motor- The motor after being disconnected from the supply is made to excite as a series generator. For this it is necessary that the total resistance in the motor circuit should be less than the critical resistance, so that the generator may self-excite. Also in order that the flux may build up, the connections of the armature with respect to the field have to be reversed.

(c) Synchronous Motors

The field excitation is maintained and the motor after being disconnected from the supply is connected to resistances in star or delta. It now works as an alternator and the kinetic energy is dissipated in the form of losses in the resistances.

(d) Induction Motors

The stator is disconnected from the supply and direct steady current is passed through its windings. A flux is produced. When the short-circuited rotor conductors cut this steady flux emf is induced in them which provide the necessary braking effect. If the rotor is wound, the braking torque can be controlled by the insertion of suitable resistances in the rotor circuit.

**Regenerative Braking**

In regenerative braking the motor is run as generator by the kinetic energy of the load which is returned to the mains as electrical energy. There is, therefore, an overall saving in energy.

(a) D.C.Motors-shunt: If the emf generated by the motor is greater than the supply voltage, power will be fed back into the supply. The emf in a shunt motor depends upon its excitation and speed. If the field is disconnected from the supply and the field current is increased by exciting it from another source, the induced emf will exceed the supply voltage and the motor will feed energy into the supply. The speed of the motor, however, falls to value corresponding to the field current at any instant. The condition is shown in Figure.

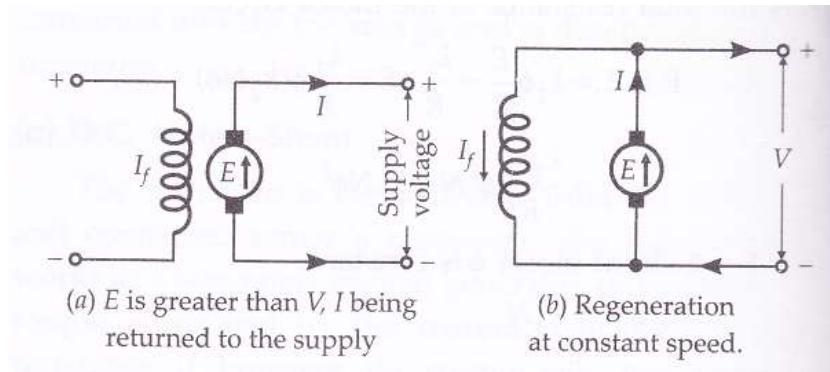

Fig.23. Regenerative Braking with d.c. shunt motor

There is another way in which regeneration takes place resulting in braking effect. If the field excitation does not change but the load causes the speed to increase, the induced emf may become greater than the supply voltage and power will be fed back in to the supply. The regenerative effect, however, will prevent any tendency of speed to increase further. This itself constitutes a form of braking effect since in the absence of regeneration, the speed would increase continuously.

(b) D.C. Motor-Series

Regenerative braking with series motors is employed mainly in traction work.

(c) Induction Motors

When an induction motor runs at a speed above the synchronous, it works as an induction generator feeding power back in to the supply. No extra devices need be employed. It may be noted that regenerative braking of induction motors is hardly useful for stopping the motor but it helps in keeping the load at a speed slightly above the synchronous and returns valuable power to the supply.

## MECHANICAL FEATURES OF ELECTRIC MOTORS

The electric motor in this section is being discussed with reference to the following:

1. Type of Enclosure
2. Bearing
3. Transmission of drive
4. Noise

### TYPE OF ENCLOSURE

This is mainly determined from a consideration of the type of work the motor has to do and the place where it is to be installed.

- I. **Open Type:** The machine is open from both ends, the bearings being placed on pedestals or brackets. There is free ventilation. Such a type of machine can be used in a separate room.
- II. **Protected Type:** Large operations are available for ventilation though some protection is provided. Mostly motors are of this type. If the openings are covered with a wire mesh or screen

the motor becomes vermin proof and better protection is afforded without in any serious manner decreasing the ventilation.

- III. **Drip proof Type:** Such motors are used where the atmosphere is very damp.
- IV. **Totally enclosed Type:** Such type of motors is used where the atmosphere is dusty i.e. saw mills, coal-handling plants and stone crushing quarries. No foreign particle should enter the motor and block passage of ventilation. The ventilation facilities are very poor in view of closed construction. To improve this, the outer surface is finned to increase the cooling area. A totally enclosed motor fitted with an outer casing built round the motor proper through which clean air is circulated with a fan is common these days.
- V. **Pipe ventilated type:** The large sizes of the totally-enclosed motor employ pipe ventilation. Clean air forced through the piping to cool the motor. The extra cost of piping is offset by the smaller size of motor that can be employed on account of better cooling.
- VI. **Flame-Proof Type:** Necessary for explosive atmosphere met with in coal mines, chemical plants etc.

### BEARINGS

The modern tendency is to use ball or roller bearings up to about 100 hp size as they have longer life and maintenance cost are low. These type of bearings are replacing old journal type bearings. They have enabled induction motors to be built with a very small air-gap. For large size motors and for reduction in the noise level, the journal type bearing is used.

### TRANSMISSION OF DRIVE

The transmission of power from the driving machine may be arranged in various ways listed below. The choice of the motor speed is an important consideration. The cost per HP decreases with an increase in speed while the efficiency and power factor improve with speed. Therefore, a high speed motor is preferable to a low-speed one and if the speed of the work is to be low it can be achieved by reduction gears or other suitable means. Motors for low-speed drivers are manufactured now with the reduction gear incorporated in the unit itself so that the high speed motor gives a high efficiency and is less expensive.

**Belt Drive:** Maximum power of about 300hp can be transmitted. Slip is about 3 to 4 percent.

**Rope Drive:** A number of ropes are run in v-grooves over pulleys. It is used where the power is beyond the scope of belt drive. Slip is negligible.

**Chain Drive:** More expensive than the above two forms but more efficient and there is no slip. It can be used for greater speed ratio; the limit is 6:1.

**Direct Drive:** The motor is in the line with the driven machine. To protect the motor from sudden jerks, flexible couplings are used.

**Vertical Drive:** The motor shaft is vertical. The arrangement is sometimes convenient.

### NOISE



In any industrial establishment, it is important to keep the noise level to as a low as value as possible so that fatigue to workers may be avoided. For domestic appliances, the motors used must be almost noise less and the same applies to appliances used in hospitals, theatres, etc. The noise produced depends upon the loudness and shrillness of the note emitted. The level of sound is measured in decibels.

In motors noise may be produced due to mechanical features like bearings, vibration and bad foundation. It is for the manufacturer to improve these. But the transmission of noise to other parts of a building can be eliminated by foundations.

### SIZE AND RATING

The size and rating of a motor for a given service dependent upon its temperature rise. The maximum temperature rise is limited by the type of insulation used. For class A Insulation a maximum temperature rise of  $40^{\circ}\text{C}$  is permissible. For class B insulation value is  $50^{\circ}\text{C}$ .

Standard Ratings for Motors: The I.S. specifications classify the motors for service as follows:

Continuous Rating: A motor capable of giving the output continuously without exceeding the rated temperature rise. It can also give 2.5% overload for 2 hours.

Continuous maximum Rating: Similar to the above without allowing any overload. It is used for motors of size larger than 2.5hp per rpm.

Short-time Rating: It is output that a motor can give for a specified short-time, say  $\frac{1}{2}$  hr. or  $\frac{1}{4}$  hr. without exceeding the specified temperature rise.

### MOTORS FOR PARTICULAR SERVICES

In the previous sections discussions were made regarding various aspects of performance of electric motors. The basic problem of choosing the proper motor is in matching the motor characteristics to the load requirements, i.e. load mechanics must be clearly known. On this depend the selection of the type of motor. After this comes the ability of the motor to carry the loads, this ability is limited by two factors; thermal and mechanical. Thermal consideration is with regard to the temperature rise under a given duty and mechanical is for ensuring that the peak load is carried by the motor safely.

Let us consider one or two examples for choosing a motor. Suppose we want a motor for driving a fan. The load torque varies as the square of the speed. From among A.C. motors, induction motor is suitable. The stable point of operation is shown as S on the torque-speed characteristics in Figure.

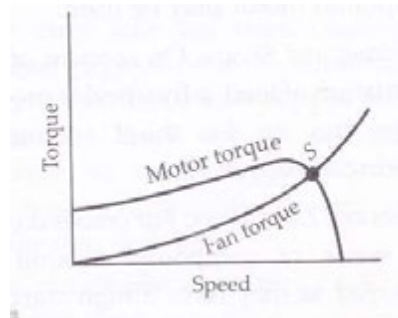

Fig.24 Fan load and induction motor torque speed curves

From D.C. motors shunt motor will be suitable. The point of stable operation is the point where the motor torque and the fan torque curves intersect each other as shown in figure.

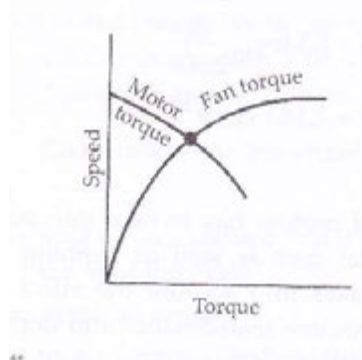

Fig.25. Fan load and shunt motor speed torque curves

Next let us consider a punching machine or shearing machine. The load is fluctuating in nature and therefore a flywheel will have to be used in order that the load demand as reflected on the supply may be smooth. A flywheel can only be used with a motor whose speed can decrease as the load comes. A D.C. shunt or compound or a 3-phase induction motor will be suitable.

Some of the motors commonly used for particular services are given below:

- i) Domestic uses: Small universal motors of the series type are used in domestic appliances like vacuum cleaners, refrigerators, washing machine, fans etc.
- ii) Grinding and milling machine: Upto 50 h.p. the motors may be D.C. shunt or induction with slip-rings and arrangement for pole-changing with cage rotors.
- iii) Planners: There is cutting stroke and a quick return stroke. Arrangements for reversing the speed have to be incorporated. A D.C. compound motor may be used.
- iv) Punching and shears: On account of heavy fluctuations of load, a flywheel is provided. The motor may be D.C. shunt or compound or slip-ring induction type.
- v) Cranes and Hoist Work: For cranes D.C. motors of series or compound type are preferred as they have a high starting torque and the speed control is smooth. Induction motors are also used for hoisting.
- vi) Lifts: duty involves high acceleration and high retardation. The motor armature must therefore be light and it should run at moderate speeds .D.C. compound, slip-ring induction, induction-repulsion motors are used.
- vii) Textile Industry: Motors must be of totally enclosed type to prevent particles of the material being manufactured from getting into them. They should also be moisture proof on account of damp atmosphere inside a textile plant.  
Three-phase motors are used since their speed is fixed by the supply frequency .D.C. motors cannot be used as their speed varies with voltage.
- viii) Printing machinery: As it requires a variable speed Induction motors using rotor resistance may be used. Where large speed variations are required D.C. compound or A.C. commutator motors may be used.
- ix) Paper Industry: Synchronous motor is used as in this a constant speed of operation is required for giving a uniform thickness of the paper. Where speed is not required to be constant, squirrel cage induction motors or D.C. motors may be used.

- x) Iron and steel Industry: D.C. shunt motors with flywheel arrangement or induction motors with speed control are used in such Industry.
- xi) Mining work: Flame proof motors are required for safety considerations in a mines for which cage motors are used up to 10 hp and for large output slip-ring or D.C. motors are used.

Type of motor	Voltage limit	H.P. limit	$I_{starting}$ $I_{full load}$	$T_{starting}$ $T_{full load}$	Methods of	Speed-torque characteristic	Range of speed control	Methods of speed control	Applications
Squirrel-cage induction motor	11 V	300	1	1	<ul style="list-style-type: none"> <li>Start-delta starter</li> <li>Auto-transformer starter.</li> <li>Resistance in stator circuit.</li> </ul>		Small variation in speed from no load value due to slip.	<ul style="list-style-type: none"> <li>Pole changing.</li> <li>Variation of frequency.</li> </ul>	Industrial cranes of small power having explosive atmosphere. Water pumps and Tube-wells.
Single-phase induction motor	250 kV	1	Capacitor start 2 repulsion start 2	Capacitor start 1.5 repulsion start 3	<ul style="list-style-type: none"> <li>Repulsion start</li> <li>Pole shading</li> <li>Phase splitting by L or C and R in series with one of the windings.</li> </ul>		Small variations due to slip.	By voltage drop in series impedance.	Fans, record-player-compressors, refrigerators, washing machines, medical apparatus, vacuum cleaners, air conditioning installations.
Pole-changing induction motor (Squirrel cage)	11 kV	300	6	1	<ul style="list-style-type: none"> <li>Direct switching up to 5 hp.</li> <li>Start-delta starter.</li> <li>Auto-transformer starter.</li> </ul>		2 to 4 fixed ratios	<ul style="list-style-type: none"> <li>Pole-changing.</li> <li>Variation of frequency.</li> </ul>	Cranes, lathes drills, lifts-high speed winding is used for acceleration and low speed for rateratio and landing.
Synchronous motor	15 kV	10000	2	3/4	<ul style="list-style-type: none"> <li>By pony motor</li> <li>By damper windings.</li> </ul>		Fixed speed	Fixed speed (which depend on frequency).	Motor generator sets, frequency changers, fans, compressors, pumps, lineshafts, calenders and rolling mills. Small motors for clocks.
Discharge motor	1 kV	1000	2	2.6	<ul style="list-style-type: none"> <li>Applying low voltage.</li> <li>Direct switching keeping the brushes in low speed position.</li> </ul>		3 : 1	<ul style="list-style-type: none"> <li>Shifting the brushes.</li> <li>Inserting impedance in secondary winding.</li> </ul>	Paper making machines, printing presses, textile work, lifts, pumps, machine tools, belt conveyors.

Summary of the characteristic and the field of application of the various types of motors

Type of motor	Voltage limit	H.P. limit	$\frac{I_{starting}}{I_{full\ load}}$	$\frac{T_{startin}}{T_{full\ load}}$	Methods of	Speed-torque characteristic	Range of speed control	Methods of speed control	Applications
Shunt motor	3000 V	25000	2	2	Series resistance in armature removed in steps.		4 : 1	<ul style="list-style-type: none"> <li>Inserting variable resistance in field circuit.</li> <li>Inserting variable resistance in armature circuit.</li> </ul>	For driving line shafts, lathes, milling machines, conveyors, fans.
d.c. series motor	1500 V	3000	2	3	<ul style="list-style-type: none"> <li>Series resistance.</li> <li>Series-parallel method in traction work.</li> </ul>		3 : 1	<ul style="list-style-type: none"> <li>By field diverter.</li> <li>By tapping the field.</li> <li>Variable resistance in series with the motor.</li> <li>Series-parallel control in traction work.</li> </ul>	Traction ; haulage ; crans and moving heavy slides.
Compound motor	1500 V	3000	2	2.3	Series resistance in armature removed in steps.	Can be adjusted between that of pure shunt and pure series motor.	3 : 1	<ul style="list-style-type: none"> <li>Variable resistance in shunt field circuit.</li> <li>Series field circuit.</li> <li>Combination of 1 and 2.</li> </ul>	Shears, punches, elevators, conveyors, heavy planners, rolling mills for intermittent high torque load.
d.c. series motor	500 V	3000	2	3	Variable voltage applied from the secondary of a transformer with tappings.		Full range with transformer	By voltage variation.	Traction work.
Slip-ring induction	11 kV	11000	2	2	Resistance in rotor circuit.		Small variation in speed from no load value due to slip.	<ul style="list-style-type: none"> <li>Variation of applied voltage.</li> <li>Variation of frequency.</li> <li>Pole-changing.</li> <li>Cascading.</li> <li>Rotor rheostat control</li> <li>Injecting e.m.f. in rotor.</li> </ul>	Generators, line shafts, lifts, pumps ; mills, winding machines, haulage.

## ELECTRIC TRACTION

### Introduction

*The system of traction involving the use of electricity is known as the electric traction system*

In the earlier stages of the development of Electric traction two systems have been in use –D.C. at 1500 volts or 3000 volts and single-phase a.c. at 11 to 16kV using low frequency. The reasons for the adoption of low frequency rather than the standard 50-cycle frequency was that the series-wound commutator was developed for satisfactory operation only up to about 25 cycles and the low frequency was suitable for the hydro-generators of the railways which had to generate their own power in the absence of any national grids that exist today. The d.c series motor has ideal characteristics for traction purpose. D.C. was already in use for tramways and in about 1905, on account of the better performance of d.c. series motor due to the introduction of the inter-poles and adoption of higher voltage with increased spacing of the substations the traction became economical. The two systems i.e. D.C. and A.C. developed and grew side by side.

In India we have the single-phase A.C. at 25kV,50 cycles is supplied to the locomotives which carries transformers and rectifiers. A.C. is converted into D.C. in the locomotive and traction motors are D.C. motors. However, recently A.C. traction motors are being attempted.

### SYSTEM OF TRACTION

There are various systems of traction are commonly used such as

1. Direct steam engine drive
2. Direct internal combustion engine drive
3. Steam electric drive
4. Petrol electric traction
5. Battery electric drive
6. Electric Drive
7. Internal combustion engine electric drive

### **Direct Steam Engine Drive:**

The steam engine drive used to be widely employed for railway work. In this drive the reciprocating steam engine is invariably used for getting the necessary motive power because of its inherent simplicity, operational dependability, and simplified maintenance, the simplicity of connections between the cylinders and driving wheels and easy speed control. It causes no interference to the communication lines running along the track. It is cheap for low density traffic areas and initial stages of communication by rail.

### **Direct Internal Combustion Engine Drive:**

Direct internal combustion engine drive is widely employed for road transport. The efficiency of internal combustion engine at its normal speed is about 25 percent. It is self-contained unit and it is not tied to any route. Initially the cost of vehicle and garage is very low. Speed control and braking system employed is very simple. It is cheap drive for the outer suburbs and country districts.

### **Steam Electric Drive:**

A few locomotives employing steam turbine for driving a generator used for supplying current to electric motors have been built for experimental purposes.

### **Internal Combustion Engine Electric Drive:**

In this drive the reduction gear and gear box are eliminated as the diesel engine is to drive the dc generator coupled to it at a constant speed. This type of drive has found considerable favour for railway work and locomotives of this type are becoming widely used.

### **Petrol Electric Traction:**

This system has been used in heavy lorries and buses. Due to electric conversion, it provides a very fine and continuous control which makes the vehicle capable of moving slowly at an imperceptible speed and creeping up the steepest slope without throttling the engine.

### **Battery Electric Drive:**

In this drive the locomotive carries the secondary batteries which supply power to dc motor employed for driving the vehicle. Such a drive well suited for frequently operated service such as local delivery of goods in large towns with maximum daily run of 50 to 60 km, shunting and traction in industrial works and mines. The major limitation of this type of drive is the small capacity of the batteries and the necessity for frequent charging, speed range is also limited.

### **Electric Drive:**

The drive of this type is mostly widely used. In this system of traction the vehicle draws electrical energy from the distribution system fed at suitable points from either a central power station or substations.

## System of Electric Traction

Two types of vehicles are in use for electric traction. In one type they receive power from a distribution network while in the other type they generate their own power. The former type vehicles may use both a.c. or d.c. ; the latter type will be the diesel-electric car or train, petrol-electric truck, lorry and battery driven vehicles.

### DC TRACTION MOTOR

Most suitable motors for dc system are the series and compound motors.

#### DC Series Motor:

The series motor used for traction purposes have following requirements

1. The dc series motor develops high torque at start which is essential for traction services.
2. The series motor is simple speed control method.
3. Power drawn from supply mains varies as the square root of the load torque.
4. In case of dc series motor commutation is excellent up to twice full load so replacement of brushes in not required frequently.
5. In cases of dc series motors the flux varies as the armature current, torque corresponding to a given armature current, therefore is independent of line voltage.
6. In case of dc series motor up to magnetic saturation, torque developed is proportional to the square of the armature current. Thus dc series motor requires comparatively less increased power input with the increase in load torque.
7. The series motor when operated in parallel to drive a vehicle by means of different axles, share load almost equally even there is unequal wear of different driving wheels.
8. The dc series motor is simple and robust in construction.

## AC TRACTION MOTOR:

**AC Series Motor:** Many single phase ac motors have been developed for traction purposes but only compensated series type commutator motor is best for traction. The construction of an ac series motor is similar to a dc series motor except that some modification such as whole magnetic circuit laminated, series field with as few turns as possible, large no of armature conductors, use of carbon brushes, numerous poles with lesser flux per pole. Compensating windings are provided to neutralize armature reaction and commutating or interpoles are provided for better performance in terms of higher efficiency and a greater output from a given size of armature core. The speed –Torque characteristics and the speed-current characteristics of compensated series type commutator motors are similar to those of D.C. series motor. The a.c. Series motor is not suitable to suburban services where stops are frequent. It is being extensively employed on main line work on the continent and in America and provides good service.

If a d.c. series motor is worked on a.c. it would not operate in a satisfactory manner. Though the torque on the armature would be unidirectional, it would be at double the frequency since both the field current and the armature current reverse every half cycle. The alternating flux would cause heavy iron losses in the field and yoke. Heavy sparking would also take place at the brushes since the induced voltage and currents in the armature would be short-circuited at the time of commutation. The overall performance of the motor would be poor.

The difference between d.c. and a.c. operation can be understood by a reference to figure shown below.

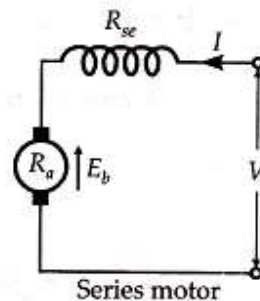

Fig. 1 DC series wound motor

Operation on d.c. is simple enough.  $I$  is the current drawn by the motor,  $IR_{se}$  and  $IR_a$  are the drops in the series field and the armature respectively.  $E_b$  is the back emf developed and equals  $k\phi N$ .

Mathematically, we have

$$V = E_b + IR_{se} + IR_a$$

Since  $I(R_{se} + R_a)$  drop is about 10 percent of the applied voltage,  $E_b$  is practically equal to  $V$ .



In order to improve the performance of the motor on a.c., a compensating winding in series with the armature is to be provided. The effect of the compensating winding is to reduce the armature reactance of the motor which increases the value of  $E_b$  and provides better speed regulation. The armature and field mmfs are at right angles to each other. The compensating winding provides an mmf opposite to the armature mmf and therefore considerably reduces the armature reactance drop. This is shown below

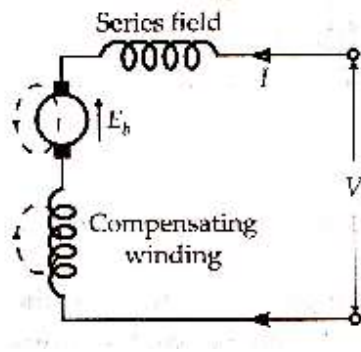

Fig. 3 Circuit diagram of the series motor with compensating winding

$R_a + R_c$  represent the resistances of the armature and compensating winding.

$X_a + X_c$  represent the reactances of the armature and compensating winding.

Fig. below shows the case where the compensating winding is short-circuited on itself. It acts like the short-circuited secondary of a transformer and greatly reduces the effect of the armature reactance. It is also seen that by using the compensating winding, the power factor of the motor improves as shown in the figure below.

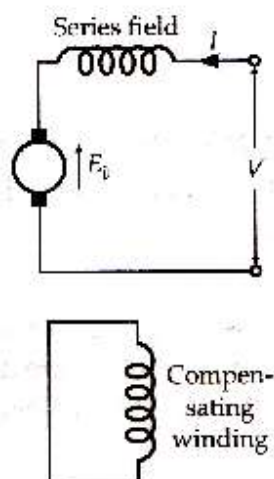

Fig.4. Circuit diagram for an inductively compensating series motor

## THREE-PHASE INDUCTION MOTOR

Although it is robust and the simplest in construction, the difficulties in starting and speed control do not make it suitable for traction work. The speed torque curve is flat. It has been used in the Kando system in Hungary and some sections of Italian State Railways. It was not likely to find further application elsewhere though in recent years, with power electronic method of speed control, research is being undertaken to apply this drive in traction.

### CONTROL OF MOTORS

#### CONTROL OF D.C. MOTORS

The starting current taken by a D.C. motor during its starting period is limited to a value approximately equal to the normal rated current by the resistance of the starter. There is a considerable loss of energy at the starting resistance. Consider the use of a single motor started by a resistance starter, the average value of the current during the starting period being limited to  $I$ , the normal full-load current.

The back emf of the motor starts to build up from zero magnitude. At the instant of switching on the supply,  $E_b=0$ , a current of  $I$  amperes is drawn from the supply and the supply voltage is the sum of the IR drop in the motor armature and the voltage drop across the starting resistance. At any other instant during starting, the supply voltage = (motor back emf)+(IR drop in the motor armature)+(voltage drop across starting resistance).

At the end of the accelerating period, the back emf has developed to a full value and the supply voltage =(back emf)+(IR drop).

#### SERIES PARALLEL STARTING

In traction work, usually two or more similar motors are employed. Considerable saving energy can be affected by employing series-parallel starting. Consider the use of two series motors. They are started in series with the help of a starting resistance till each of them develops a back emf equal to half the supply voltage minus the IR drop. The motors give one running speed when they are in the full series position. The starting resistance is again re-inserted in the circuit and the motors are switched in parallel. The starting resistance is cut out in steps and the back emf of each motor develops from about half the value to the normal value. In the full parallel position the motors give another running speed which is obviously higher than that when the motors are in full series.

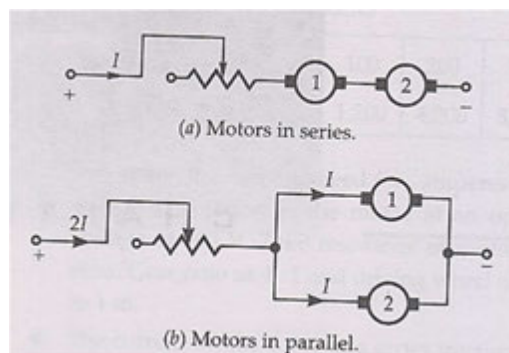

Fig.7. Series Parallel starting

Let the current during the starting interval be limited to the normal rated current  $I$  per motor. During the series period a current of  $I$  amperes is drawn from the supply while during the parallel period a current of  $2I$  is drawn.

The series-parallel method enables a saving of about 15 to 20 % in the energy.

## The Series-Parallel Control

The series-parallel control is carried out as follows:

(a) Shunt Transition: The various stages involved in this method of series-parallel control are shown below.

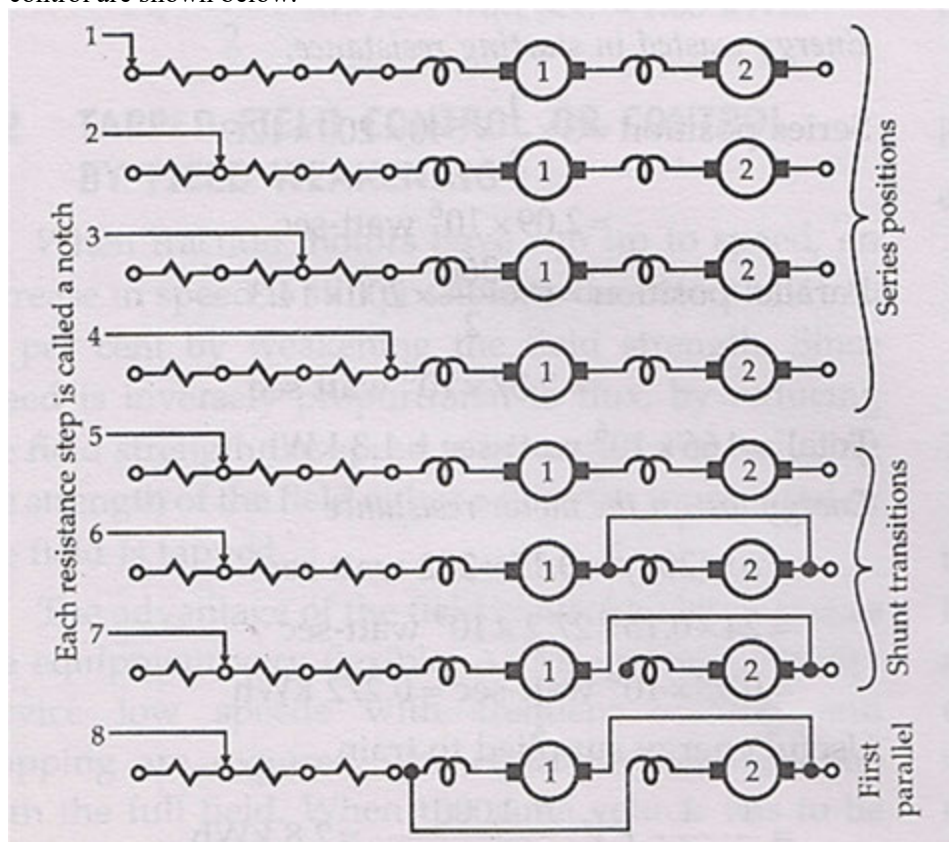

Fig..11 Series position

In steps 1,2,3,4 the motors are in series and are accelerated by cutting out the starting resistance in steps. In step 4 , the motors are in full series. During transition from series to parallel, the resistance is re-inserted in the motor circuit (step-5). One of the motors is by-passed (step-6) and disconnected from the main circuit (step-7).

It is then connected in parallel with the other motor (step-8) giving the first parallel position. The resistance is then cut out in steps completely and the motors are placed in parallel.

This method is known as the shunt-transition method.

(b) Bridge Transition: the motor and the starting rheostats are connected in the form of a Wheatstone bridge as shown below.

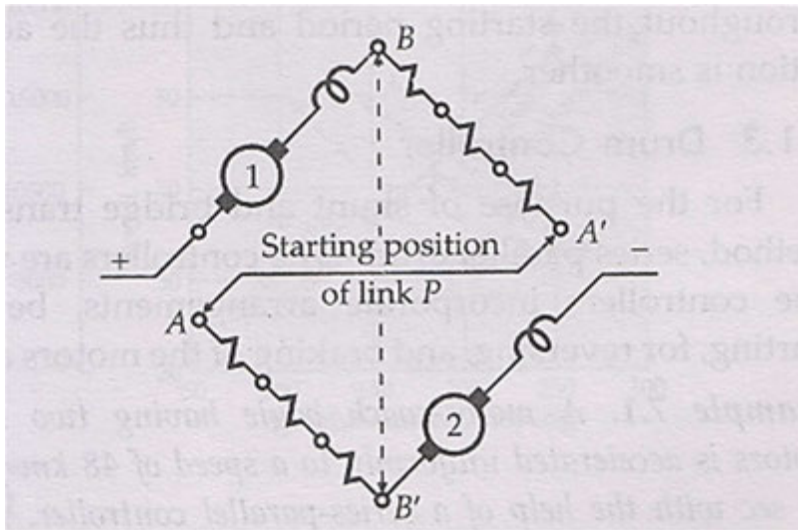

Fig.9. Series position.

- (a) At starting, motors are in series with link P in position AA'
- (b) Motors in full series with link P in position BB'

In the first starting position the motors are in series and the rheostats are completely in circuit as indicated by the rheostats arm P at A A'. A and A' are moved in the direction of the arrowheads and in position BB' the motors are in full series.

In the transition step, the rheostats are reinserted by connecting to positive and negative of the supply as shown below.

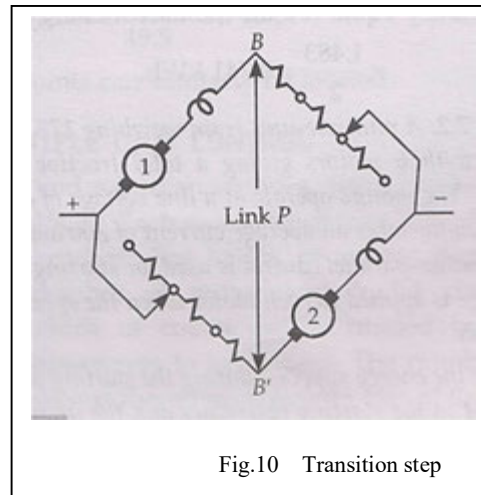

Fig.10 Transition step

In the first parallel step, the link P is removed and the motors are connected in parallel with the starting resistances in their circuit.

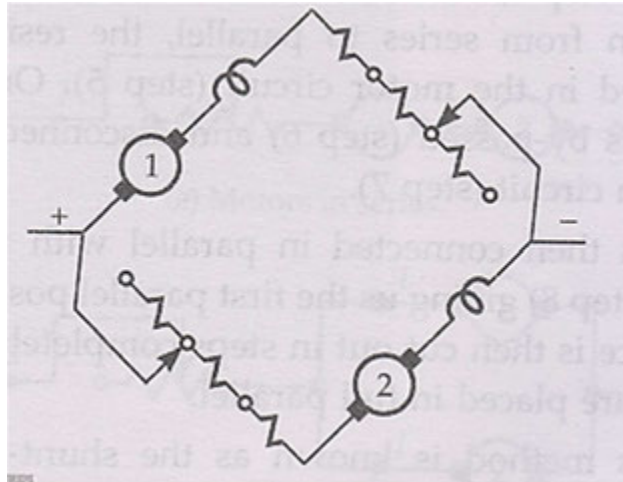

Fig.11 First Parallel position

The advantage of the bridge transition method over the shunt transition method is that the normal accelerating torque is available from both the motors throughout the starting period and thus the acceleration is smoother.

### **Tapped Field Control:**

As the speed of the motor is inversely proportional to the flux (assuming line voltage constant), therefore, the speed can be varied by varying the flux. In case of series motors the flux can be varied either (i) by connecting a variable resistance known as diverter in parallel with the series field winding or (ii) by cutting out some of the series field turns. Since in both the cases the flux can be only reduced, therefore, this method is known as field weakening method and speeds above normal can be obtained. By this method speed can be raised to the extent of 15 to 30 percent of normal speed owing to design difficulties arising with traction motors.

The field weakening method is of no use for starting purpose. This method is used for increasing the speed of traction motors upto the extent of 10 to 15 percent when they have attained maximum possible speed by series-parallel control system. The advantage of this system is that it increases the flexibility of the train utility.

### **THE METADYNE SYSTEM OF CONTROL FOR D.C. MOTORS**

In the series-parallel control of D.C. traction motors, there is considerable loss of energy in the starting resistances. The metadyne system of control estimates the energy loss and achieves a very smooth control during the acceleration period.

Metadyne is a special machine which consists of two pairs of brushes or has an additional set of brushes. This arrangement enables the armature MMF to provide most of the excitation and achieve higher power gains.

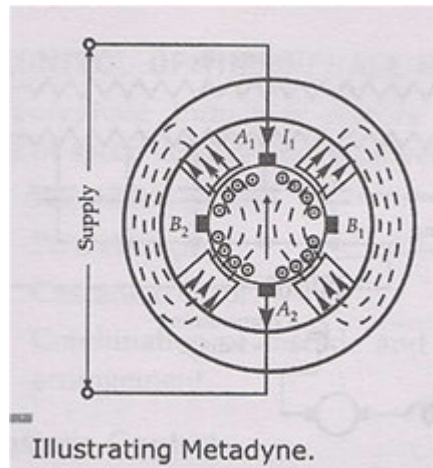

Fig.12 Illustrating Metadyne

Consider a D.C. armature with two brushes and two poles. If current is supplied to the two brushes  $A_1A_2$  the armature cross-flux will be as shown and mainly confined to the poles as shown in Figure. If there are four brushes, current is supplied to brushes  $A_1A_2$  and the armature cross-flux will take up the path as shown below. If now the current is supplied to brushes  $B_1B_2$  as shown the armature cross-flux takes up path as indicated. If the armature is rotated at a constant speed and a current  $I$  is fed into the bushes  $A_1A_2$ , an emf is induced in the winding between  $B_1B_2$  due to the flux produced by  $I$ . No emf is induced between  $A_1A_2$  and the voltage between  $A_1A_2$  is on account of the voltage drop due to  $I_1$ .

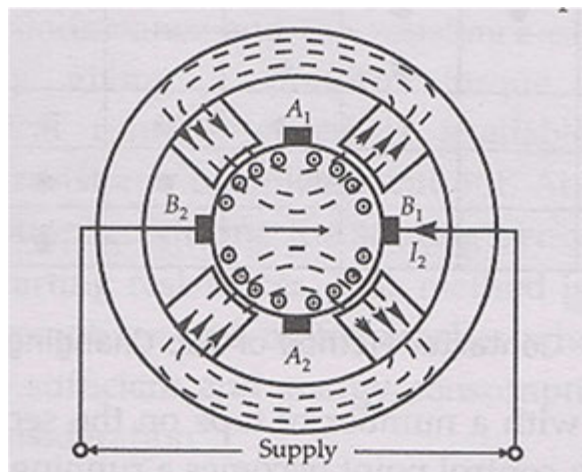

Fig.6.14

Since an emf is induced across  $B_1, B_2$  a current  $I_2$  will flow in a load connected between them. The resultant flux distribution on account of  $I_1$  and  $I_2$  is as shown below.

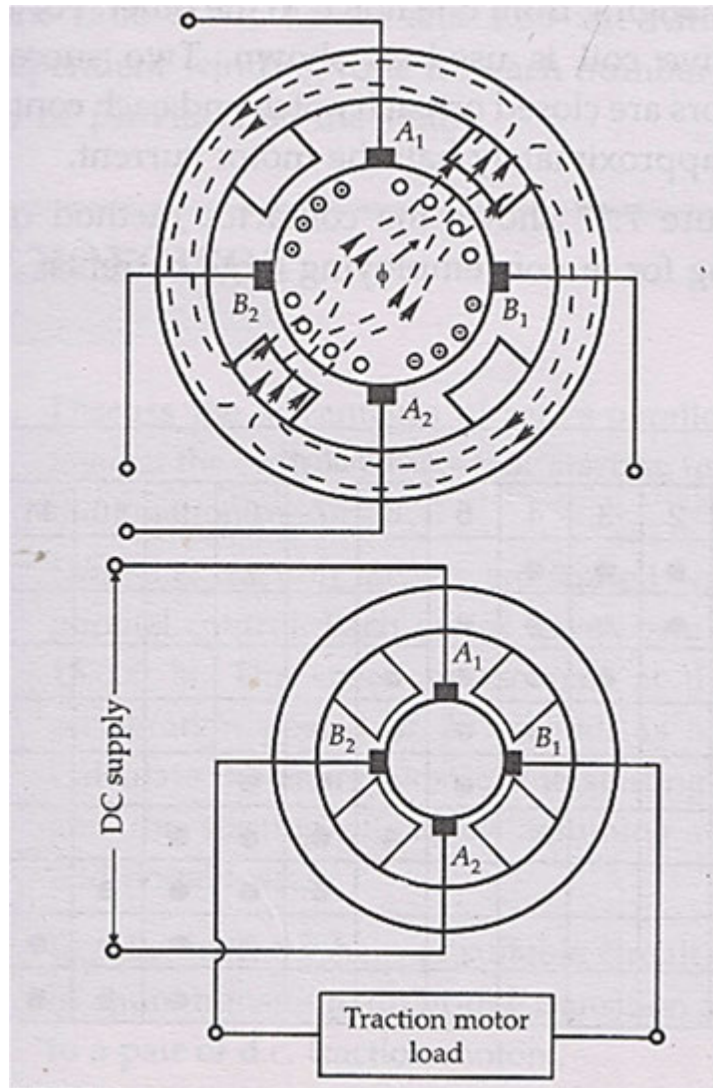

Fig.15

The total flux may be assumed to be made up of two components  $\phi_1$  and  $\phi_2$  at right angles and directed along  $A_2A_1$  and  $B_2B_1$ . The rotation of the armature in  $\phi_2$  induces an emf  $E_1$  between  $A_1$  and  $A_2$  which opposes the supply voltage. Since the current is to be kept at its original value of  $I_1$ , the supply voltage must be induced to overcome  $E_2$ . Under steady conditions

$$E_1 \propto \phi_2 = KI_2$$

$$E_2 \propto \phi_1 = KI_1$$

$$E_1 I_1 = E_2 I_2 = K I_1 I_2$$

This shows that the machine behaves like a D.C. transformer. Only the rotational losses of the machine need be supplied by the driving motor.

If the supply voltage  $E_1$  remains constant,  $I_2$  remains constant. The arrangement therefore is quite suitable for starting D.C. motors

**Rheostatic Control** :A series motor can be started by connecting an external resistance (starter) in series with the main circuit of the motor. At the starting instant, since the back emf developed by the motor is zero, therefore, the resistance connected in series with the motor is maximum and is of such a value that the voltage drop across it with full load rated current is equal to the line voltage. As the motor speeds up, the back emf developed by the motor increases, therefore, the external resistance is gradually reduced in order to maintain the current constant throughout the starting or accelerating period. Basic traction motor circuit with rheostatic starting is shown in figure. In this method there is a considerable loss of energy in the external circuit.

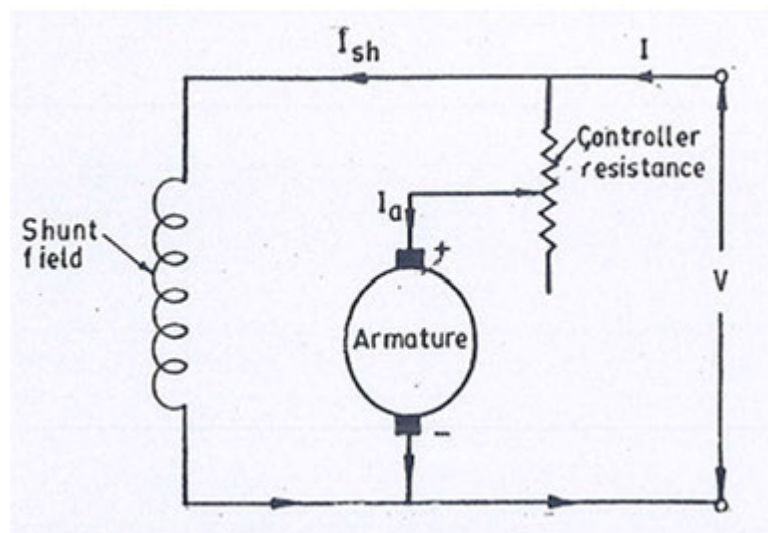

Fig.16 Rheostatic control method

## BRAKING

### Introduction

In traction work both electrical and mechanical braking are employed for bringing the vehicle to rest. Electrical braking cannot do away with the mechanical brakes since a vehicle cannot be held stationary by its use; it nevertheless forms a very important part of a traction system. The main advantage of using electric braking is that it reduces the wear on the mechanical brakes and gives a higher value of braking retardation thus bringing a vehicle quickly to rest and cutting down considerably on the running time. Where regenerative braking is employed, a part of the energy is returned to the supply thereby affecting a considerable saving in the running costs.

For D.C. motors there are three methods employed for electric braking:



- (i) **Plugging**
- (ii) **Dynamic braking / Rheostatic braking**
- (iii) **Regenerative braking**

## REGENERATIVE BRAKING

When a train is accelerated up to a certain speed, it acquires kinetic energy corresponding to that speed. During the coasting period, a part of this kinetic energy is used up in overcoming the fractional resistance and some part is utilized in the propulsion of the train. The kinetic energy, which is utilized in the propulsion, does useful work and therefore coasting may be regarded as “ mechanical regenerative braking “ since the speed gradually decreases on account of the utilization of the kinetic energy stored in the train at the end of the accelerating period.

A system of track grading is employed in the case of the underground railway where the kinetic energy of a train may be used in doing useful work against gravity. Two types of graded tracks are shown in Figure below.

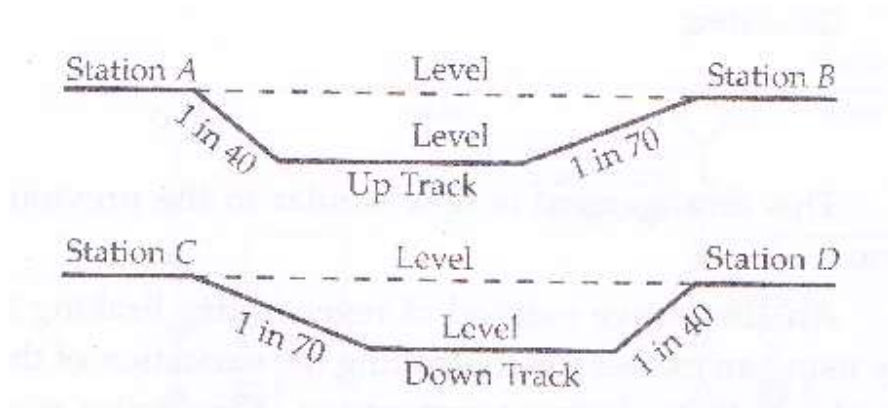

Fig.18 Track Grading

When the train is at a station, say A, it possesses a certain potential energy which is utilized in its descent down the gradient till it reaches the level tracks. However, graded track construction is only possible in the case of the underground railway and is not practicable for surface railway.

### Regenerative Braking with D.C. Motors

The terminal voltage of the D.C. motor must exceed the supply voltage for regeneration to take place. Also, this voltage must be kept at this value irrespective of the variation in speed or braking torque. The D.C. series motor cannot be used for regenerative braking without modification for this reason. During regeneration, the current through the armature reverses and since the excitation has to be maintained, the field connection must be reversed, if a short-circuit condition is to be avoided. For, if the field connection were not reversed the regenerated current in it would reverse the field which would reverse the emf of the motor and the supply voltage and back emf would aid each other setting up a short-circuit condition.

One method of regenerative braking with series motors is the French method. If there is a single series motor as in the case of a trolley-bus it is equipped with a main series field auxiliary any field windings placed in parallel with the main series winding.

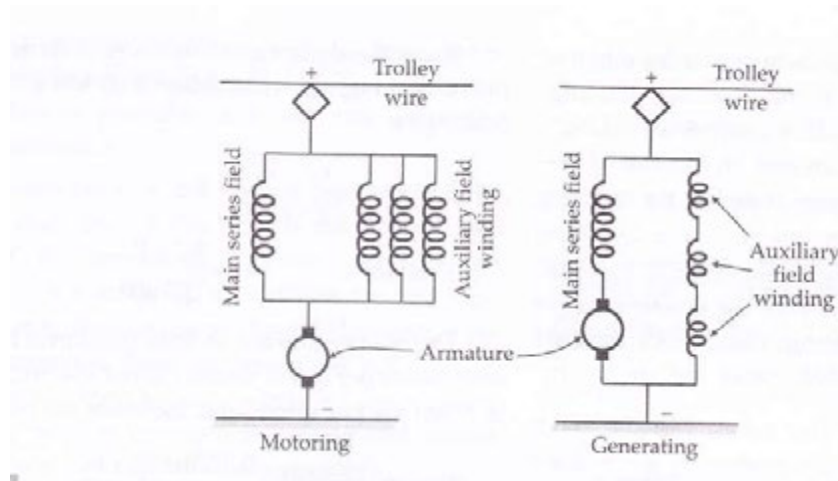

Fig. 20 Regenerative braking

During regenerative braking the auxiliary field windings are placed in series with each other and switched over in parallel across the armature and the main series field. The machine acts as a compound generator with slight differential compounding. If there is a change in the line voltage, the shunt excitation being sensitive to such changes, immediately causes the emf of the generator to increase or decrease thus providing the necessary balance. Suppose the line voltage tends to increase beyond the emf of the generator. The increased voltage across the shunt circuit will send a large exciting current through it causing the emf of the generator to rise. The reverse of this happens when the line voltage tends to fall. The arrangement is, therefore, self-compensating.

In locomotives where four or six series motors are used, there need not be any auxiliary windings. During normal working all the motors are in series within their respective field windings but during regeneration, the motor armature is in parallel with the field windings of all other motors except one.

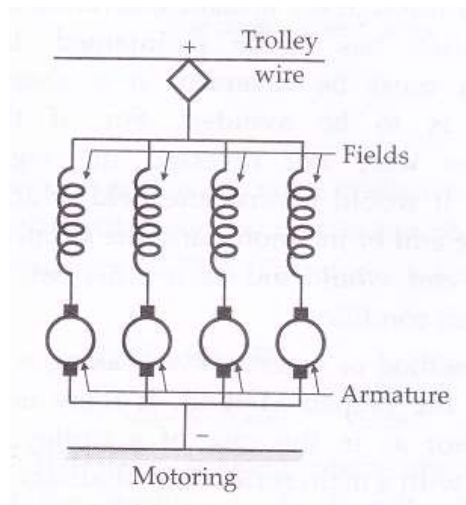

Fig.21 Regenerative Braking

This arrangement is now similar to the previous one. An alternative method of regenerative braking by using an exciter for controlling the excitation of the field winding during regeneration. The exciter may either be axle driven or noticed from an auxiliary supply.

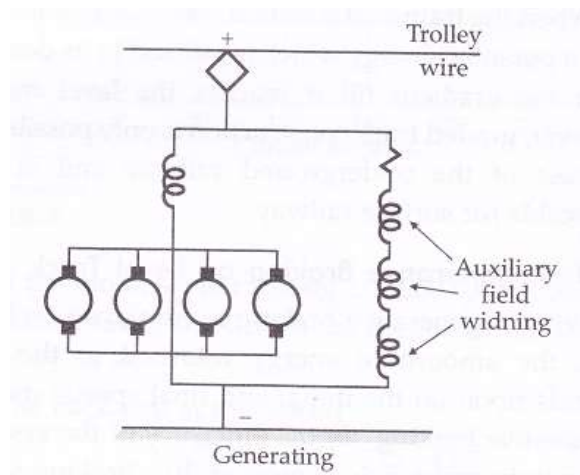

Fig. 22 Regenerative braking (alternative)

### Limits of Braking

Regenerative braking is employed down to a speed of 16 km/hr. Then rheostat braking to about 6.5 km/hr and then mechanical brakes are used to bring the vehicle to rest.

## REGENERATIVE BRAKING WITH THREE-PHASE INDUCTION MOTORS

Regenerative braking with three-phase induction motor occurs automatically when the motor runs at a speed slightly above the synchronous. It then works as induction generator. The induction generator however is not self-starting and must be connected to a system supplied from synchronous generator.

The torque-curve of an induction motor is as shown below. With no extra resistance in the rotor circuit, there is only a slight variation of speed with torque. By adding extra resistance in the rotor circuit the speed increases for a particular braking torque. Therefore while braking without any extra resistance in the rotor circuit; the speed will be kept almost constant independent of the gradient and the load of the train. This is a great advantage with the induction motor when used for traction.

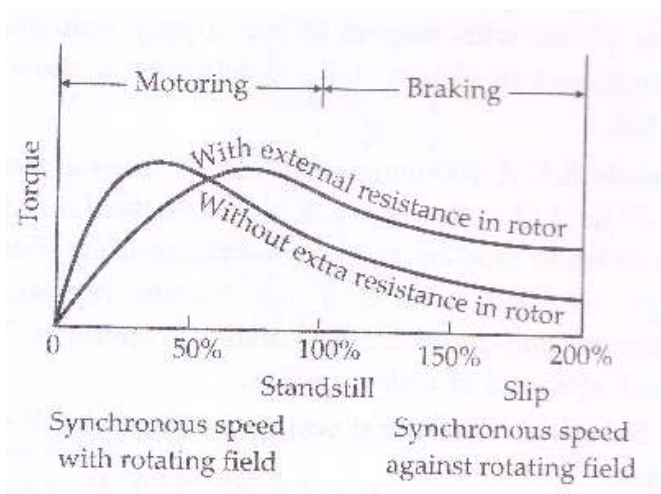

Fig.24 Torque speed curve of an Induction motor

## BRAKING WITH SINGLE-PHASE SERIES MOTORS

In this case both rheostatic and regenerative braking are possible.

**Rheostatic Braking:** The motors are worked as separately excited generators supplying energy to resistance load. The fields are energized at low voltage from suitable tapings on the train transformer. The kinetic energy of the rotor is dissipated as electrical energy in the load resistance. Also, the fields of the motors may be excited from one of the motors acting as a series generator. In this case D.C. will be generated in the rotors of the motors and the kinetic energy of rotors will be dissipated as D.C. power in the loading resistors.

### Regenerative Braking

For generative braking the regenerated power should be at the frequency of the main supply. This necessitates the energizing of the field winding from the main supply. Secondly, the regenerated current must be in phase opposition to the applied voltage and also the flux  $\Phi$  so that the power may be feedback

into the supply system. The voltage applied to the field winding must be  $90^\circ$  out of phase with respect to the supply voltage. An arrangement to obtain these conditions is shown below.

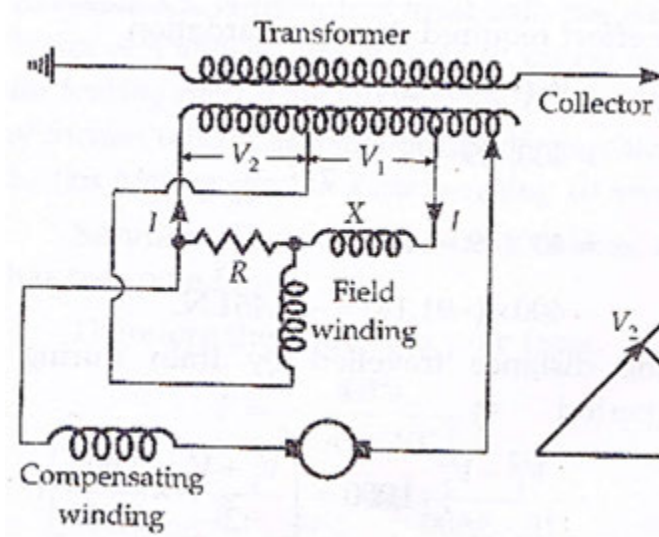

Fig.25 Regenerative braking with single phase series motor

### Magnetic Track Brake

It is used in tramcars. The electromagnet is bipolar. The body is made of cast steel and the pole faces are made of soft steel and can be renewed. The exciting coil is enclosed in a water-tight case. The magnetic flux is perpendicular to the pole faces and the track. The force of attraction between the magnet and the track is given by  $F = \frac{B^2 a}{2 \times \pi \times 10^{-7}} N$ , where B is the flux density in weber/m<sup>2</sup> and a is the area in the pole face in sq.m.

