

## LECTURE NOTES

ON

# ELECTRONICS MEASUREMENT & INSTRUMENTATION

**Compiled by**

**Mr. Abhiram Pradhan**

(Lecturer in Department of Electronics and Telecommunication Engineering, KIIT Polytechnic BBSR)

Mail id: [abhiramfet@kp.kiit.ac.in](mailto:abhiramfet@kp.kiit.ac.in)

## CONTENTS

<b>SL.No</b>	<b>Chapter Name</b>	<b>Page No</b>
1	Qualities of Measurement	3
2	Indicating Instruments	7
3	Digital Instruments	28
4	Oscilloscope	39
5	Bridges	45
6	Transducers & Sensors	56
7	Signal Generator, Wave Analyzer & DAS	71

# CHAPTER -1

## **QUALITIES OF MEASUREMENT**

### 1. INSTRUMENT AND MEASUREMENT

#### INSTRUMENT

It is a device for determining values or magnitude of a quantity or variable through a given set of formulas.

#### MEASUREMENT

It is a process of comparing an unknown quantity with an accepted standard quantity.

### 1.1. ELECTRONIC MEASUREMENT & INSTRUMENTATION

It is the branch of Electronics which deals with the study of measurement and variations of different parameters of various instruments.

- Why measurement of parameters and study of variations for a particular instrument are required?

The measurement of parameters and its variations for a particular instrument is required because it helps in understanding the behavior of an instrument.

### 1.2. CONDITION FOR A MEASURING INSTRUMENT

The measuring instrument must not affect the quantity which is to be measured.

### 2. MEASUREMENT SYSTEM PERFORMANCE:

The performance of the measurement system/instruments are divided into two categories.

- (a) Static Characteristics.
- (b) Dynamic Characteristics.

### 2.1. STATIC CHARACTERISTICS OF INSTRUMENT

These are those characteristics of an instrument which do not vary with time and are generally considered to check if

the given instrument is fit to be used for measurement. The static characteristics are from one form or another by the process called Calibration.

They are as follows:

1. ACCURACY- It is defined as the ability of a device or a system to respond to a true value of a measure variable under condition.
2. PRECISION-Precision is the degree of exactness for which an instrument is design or intended to perform.
3. REPEATABILITY- The repeatability is a measuring device may be defined as the closeness of an agreement among a number of consecutive measurements of the output for the same value of the input under save operating system.
4. REPRODUCIBILITY- Reproducibility of an instrument is the closeness of the output for the same value of input. Perfect reproducibility means that the instrument has no drift.
5. SENSITIVITY- Sensitivity can be defined as a ratio of a change output to the change input at steady state condition.
6. RESOLUTION- Resolutions the least increment value of input or output that can be detected, caused or otherwise discriminated by the measuring device.
7. TRUE VALUE-True value is error free value of the measure variable it is given as difference between the Instrument Reading and Static error.

Mathematically,

True value= Obtained Instrument reading – static error

## 2.2. DYNAMIC CHARACTERISTICS OF INSTRUMENT

The Dynamic Characteristics are those which change within a period of time that is generally very short in nature.

1. SPEED OF RESPONSE-It is the rapidity with which an instrument responds to the changes to in the measurement quantity.
2. FIDELITY-The degree to which an instrument indicate the measure variable without dynamic error.
3. LAG-It is retardation or delay in the response an instrument to the changes in the measurement.

2.3. ERROR The deviation or change of the value obtained from measurement from the desired standard value.

Mathematically,

Error = Obtained Reading/Value – Standard Reference Value.

There are three types of error.

They are as follows:

1. GROSS ERRORS-This are the error due to humans' mistakes such as careless reading mistakes in recoding observation incorrect application of an instrument. A. SYSTEMATIC ERROR-A constant uniform deviation of an instrument is as systematic error. There are two types of systematic error.

### a) STATIC ERROR

The static error of a measuring instrument is the numerical different between the true value of a quantity and its value as obtained by measurement.

### b) DYNAMIC ERROR

1. It is the different between true value of a quantity changing with and value indicated by the instrument.

2. The Dynamic Errors are caused by the instrument not responding fast enough to follow the changes in the measured value.

B. RANDOM ERROR-The cause of such error is unknown or not determined in the ordinary process of making measurement.

## TYPES OF STATIC ERROR

- i. INSTRUMENTAL ERROR- Instrumental error are errors inherent in measuring instrument because of the mechanical construction friction is bearing in various moving component. It can be avoided by
  - a. Selecting a suitable instrument for the particular measurement.
  - b. Applying correction factor after determining the amount of Instrumental error.
- ii. ENVIRONMENTAL ERROR –Environmental error are due to conditions external to the measuring device including conditions in the area surrounding the instrument such as effect of change in temperature , humidity or electrostatic field it can be avoided
  - a. Providing air conditioning.
  - b. Use of magnetic shields.
- iii. OBSERVATIONAL ERROR-

The errors introduced by the observer. These errors are caused by habits of the observers like tilting his/her head too much while reading a “Needle – Scale Reading”.

## CHAPTER-02

### INDICATING INSTRUMENT

#### 2.1 INTRODUCTION TO INDICATOR & DISPLAY DEVICES & ITS TYPES

Measuring instruments are classified according to both the quantity measured by the instrument and the principle of operation.

There are three general principles of operation:

- Electromagnetic, which utilizes the magnetic effects of electric currents;
- Electrostatic, which utilizes the forces between electrically-charged conductors;
- Electro-thermic, which utilizes the heating effect.

The essential requirements of measuring instruments are:

- It must not alter the circuit conditions.
- It must consume very small amount of power.

Electronic measuring instruments and meters are used to indicate directly the value of current, voltage, power or energy.

An electromechanical meter (input is an electrical signal results mechanical force or torque as an output) that can be connected with additional suitable components in order to act as an ammeter and a voltmeter.

The most common analog instrument or meter is the permanent magnet moving coil instrument and it is used for measuring a dc current or voltage of an electric circuit.

## 2.2 Basic principle of meter movement, permanent magnetic moving coil movement & its advantages & disadvantages.

### PRINCIPLE OF METER MOVEMENT:

- Whenever current flows through a conductor, a magnetic field proportional to the current is created. This effect is useful for measuring current and is employed in many practical meters.
- The basic dc meter movement is also known as the D'Arsonval meter movement because it was first employed by the French scientist, D' Arsonval, in making electrical measurement.
- This type of meter movement is a current measuring device which is used in the ammeter, voltmeter, and ohmmeter.
- An ohmmeter is also basically a current measuring instrument, it differs from the ammeter and voltmeter in that it provides its own source of power and contains other auxiliary circuits.

### PERMANENT MAGNETIC MOVING COIL MOVEMENT

#### CONSTRUCTION OF PMMC

- It consists of a light rectangular coil of many turns of fine wire wound on an aluminum former inside which is an iron core as shown in fig.
- The coil is delicately pivoted upon jewel bearings and is mounted between the poles of a permanent horse shoe magnet.
- Two soft-iron pole pieces are attached to these poles to concentrate the magnetic field.
- The current is led in to and out of the coils by means of two control hair-springs, one above and other below



the coil, as shown in Fig.

- These springs also provide the controlling torque.
- The damping torque which is provided by eddy currents induced in the aluminum former as the coil moves from one position to another.

### MOVING COIL:

- It is the current carrying element.
- It is either rectangular or circular in shape and consists of number of turns of fine wire..
- This coil is suspended so that it is free to turn about its vertical axis of symmetry.
- It is arranged in a uniform, radial, horizontal magnetic field in the air gap between pole pieces of a permanent magnet and iron core.
- The iron core is spherical in shape if the coil is circular but is cylindrical if the coil is rectangular.
- The iron core is used to provide a flux path of low reluctance and therefore to provide strong magnetic field for the coil to move in.
- This increases the deflecting torque and hence the sensitivity of the galvanometer. The length of air gap is about 1.5mm.
- In some galvanometers the iron core is omitted resulting in of decreased value of flux density and the coil is made narrower to decrease the air gap.
- Such a galvanometer is less sensitive, but its moment of inertia is smaller on account of its reduced radius and consequently a short periodic time.

### DAMPING:

- There is a damping torque present owing to production of eddy currents in the metal former on which the coil is mounted.

- Damping is also obtained by connecting a low resistance across the galvanometer terminals.
- Damping torque depends upon the resistance and we can obtain critical damping by adjusting the value of resistance.

### SUSPENSION:

- The coil is supported by a flat ribbon suspension which also carries current to the coil.
- The other current connection in a sensitive galvanometer is a coiled wire. This is called the lower suspension and has a negligible torque effect.
- This type of galvanometer must be leveled carefully so that the coil hangs straight and centrally without rubbing the poles or the soft iron cylinder.
- The upper suspension consists of gold or copper wire of nearly 0.012-5 or 0.02-5 mm diameter rolled into the form of a ribbon.
- This is not very strong mechanically so that the galvanometers must be handled carefully without jerks.

### INDICATION:

- The suspension carries a small mirror upon which a beam of light is cast. The beam of light is reflected on a scale upon which the deflection is measured. This scale is usually about 1 meter away from the instrument, although  $\frac{1}{2}$  meter may be used for greater compactness.

### ZERO SETTING:

- A torsion head is provided for adjusting the position of the coil and also for zero setting.

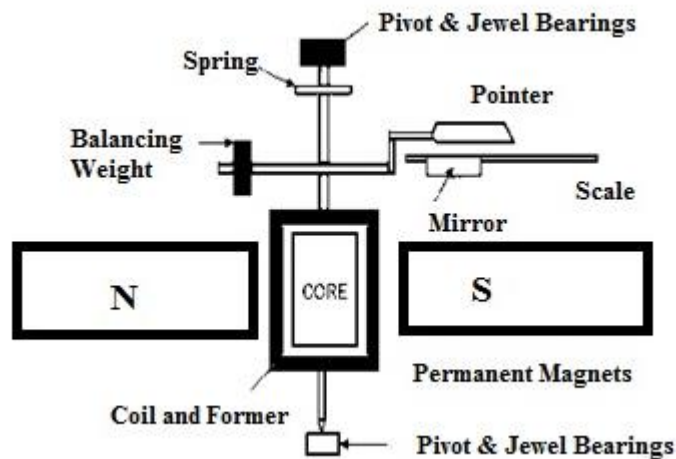

### WORKING OF PMMC

- When the input current is made to flow through the coil which is placed inside the magnetic field, the coil experiences a mechanical force.
- This mechanical force moves the coil around axis of PMMC.
- Since pointer is mechanically joined with the coil it also moves.
- Pointer arranged in such a way that it moves over the calibrated scale.
- Position of the pointer at the scale gives the value of input quantity.

### DEFLECTING TORQUE/FORCE:

- The deflection of any instrument is determined by the combined effect of the deflecting torque/force, control torque/force and damping torque/force.
- The value of deflecting torque must depend on the electrical signal to be measured.
- This torque/force causes the instrument movement to rotate from its zero position.

### CONTROLLING TORQUE/FORCE:

- This torque/force must act in the opposite sense to the deflecting torque/force, and the movement will take up an equilibrium or definite position when the deflecting and controlling torque are equal in magnitude.
- The Spiral springs or gravity usually provide the controlling torque.

### DAMPING TORQUE/FORCE:

- A damping force is required to act in a direction opposite to the movement of the moving system.
- This brings the moving system to rest at the deflected position reasonably quickly without any oscillation or very small oscillation. This is provided by air friction, fluid friction, eddy current.
- It should be pointed out that any damping force shall not influence the steady state deflection produced by a given deflecting force or torque.
- Damping force increases with the angular velocity of the moving system, so that its effect is greatest when the rotation is rapid and zero when the system the rotation is zero.

### ADVANTAGES:

- a) Uniform scale. ie, evenly divided scale.
- b) Very effective eddy current damping.
- c) High efficiency.
- d) Require little power for their operation.
- e) No hysteresis loss (as the magnetic field is constant).
- f) External stray fields have little effects on the readings (as the operating magnetic field is very strong).
- g) Very accurate and reliable.

**DISADVANTAGES:**

- a) Cannot be used for a.c measurements.
- b) More expensive (about 50%) than the moving iron instruments because of their accurate design.
- c) Some errors are caused due to variations (with time or temperature) either in the strength of permanent magnet or in the control spring.

**APPLICATIONS:**

- a) In the measurement of direct currents and voltages.
- b) In d.c galvanometers to detect small currents.
- c) In Ballistic galvanometers used for measuring changes of magnetic flux linkages.

**2.3 OPERATION OF MOVING IRON INSTRUMENT**

Moving Iron instruments are mainly used for the measurement of alternating currents and voltages, though it can also be used for D.C measurements.

**PRINCIPLE OF MOVING IRON INSTRUMENT**

- Let a plate or vane of soft iron or of high permeability steel forms the moving element of the system.
- The iron vane is situated so as, it can move in a magnetic field produced by a stationary coil.
- The coil is excited by the current or voltage under measurement.
- When the coil is excited, it becomes an electromagnet and the iron vane moves in such a way so as to increase the flux of the electromagnet.
- Thus, the vane tries to occupy a position of minimum reluctance.
- Thus, the force produced is always in such a direction so as to increase the inductance of the coil.

## CONSTRUCTION OF MI TYPE INSTRUMENT

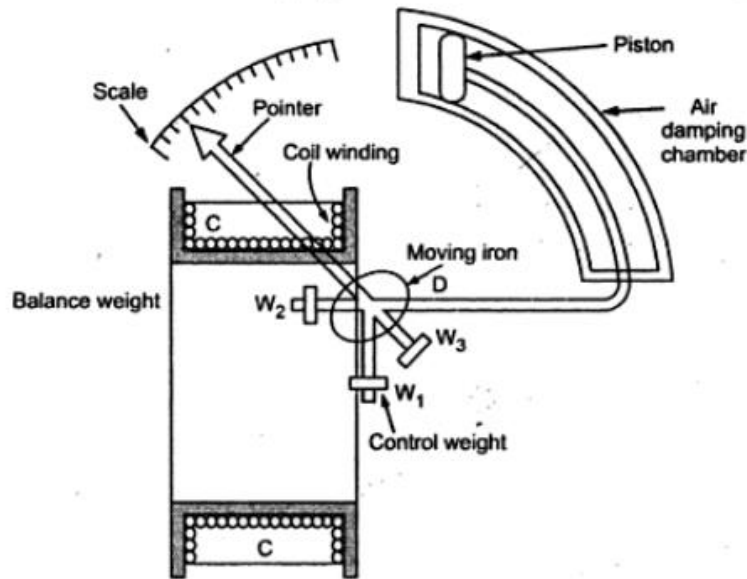

### TYPES OF MOVING IRON INSTRUMENTS:

There are two types of Moving- iron instruments

#### 1. ATTRACTION TYPE:

In this type of instrument, a single soft iron vane (moving iron) is mounted on the spindle, and is attracted towards the coil when operating current flows through it.

#### 2. REPULSION TYPE:-

- In this type of instrument two soft iron vanes are used one fixed and attached the stationary coil, while the other is movable (moving iron) and mounted on the spindle of the instrument.
- When operating current flows through the coil, the two vanes are magnetized, developing similar polarity at the same ends.
- Consequently, repulsion takes place between the vanes and the movable vane causes the pointer to move over the scale.
- Repulsion type instrument is of two types

- (a) Radial vane type: vanes are radial strips of iron.
- (b) Co-axial vane type: vanes are sections of coaxial cylinders.

### **Advantages of MI:**

- (i) It can be used for both AC and DC.
- (ii) Have high value of torque to weight ratio.
- (iii) It is very cheap due to simple construction.
- (iv) These instruments are quite robust.
- (v) These instruments can withstand large loads and are not damaged even under sever overload conditions.

### **Disadvantages of MI:**

- (i) MI instruments suffer from error due to hysteresis, frequency change and stray losses.
- (ii) Its scale is non-uniform and cramped at lower end. This is the reason of accurate readings are not possible at lower range.
- (iii) Moving Iron Instruments are suitable for low frequency application.
- (iv) The reading of the moving iron instrument is affected by temperature variation.

## **2.4. PRINCIPLE OF OPERATION OF DC AMMETER AND MULTIRANGE AMMETER**

### **D.C. AMMETER**

An ammeter is a measuring instrument which is used for the measurement of electric current in an electric circuit.

- The PMMC galvanometer constitutes the basic movement of a dc ammeter.
- The coil winding of a basic movement is small and light, so it can carry only very small currents.
- A low value resistor (shunt resistor) is used in DC ammeter to measure large current as shown in figure:

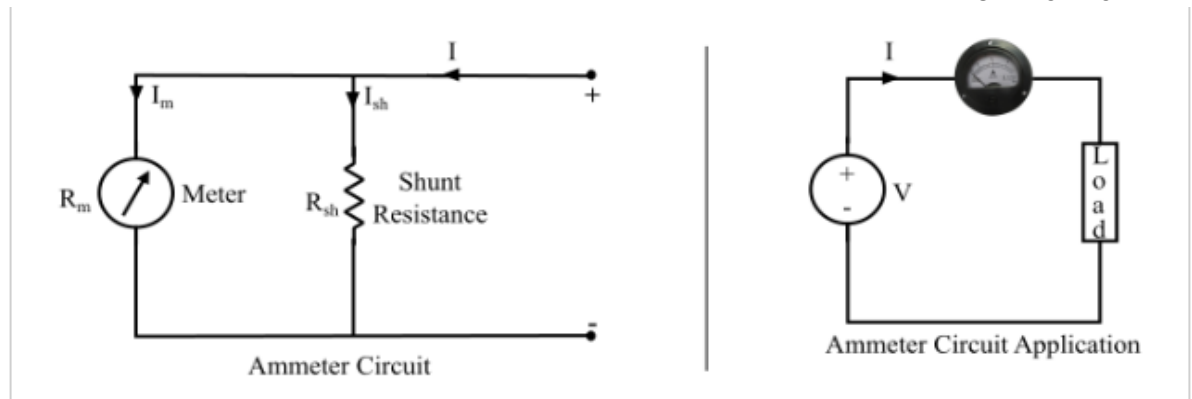

- PMMC movement can be used as DC ammeter by connecting resistor in shunt with it, so that shunt resistance allows a specific fraction of current [excess current greater than full scale deflection current (IFSD)] flowing in the circuit to bypass the meter movement.
- The fractions of the current flowing in the movement indicate the total current flowing in the circuit.
- DC ammeter can be converted into multirange ammeter by connecting number of resistances called multiplier in parallel with the PMMC movement.
- Let  $R_m$  = internal resistance of the movement.  
 $I$  = full scale current of the ammeter + shunt (i.e. total current)  
 $R_{sh}$  = shunt resistance in ohms.  
 $I_m$  = full-scale deflection current of instrument in ampere.  
 $I_{sh} = (I - I_m)$  = shunt current in ampere.
- Since the shunt resistance is in parallel with the meter movement, the voltage drop across the shunt and movement must be the same.

Therefore,  $V_{sh} = V_m$

$$I_{sh}R_{sh} = I_mR_m,$$

$$R_{sh} = (I_mR_m)/I_{sh}$$

$$\text{But } I_{sh} = I - I_m$$

$$\text{Hence } R_{sh} = (I_mR_m) / (I - I_m).$$

$$(I - I_m)/I_m = R_m/R_{sh}$$

$$(I/I_m) - 1 = R_m/R_{sh}$$



$$I/I_m = 1 + R_m/R_{sh} .$$

- The ratio of the total current to the current in the movement is called Multiplying Power of the Shunt i.e Mathematically, Multiplying Power (m) =  $I/I_m = 1 + R_m/R_{sh}$ .

### MULTIRANGE DC AMMETER:

- The range of the dc ammeter is extended by a number of shunts, selected by a range switch. Such a meter is known as Multirange DC Ammeter.
- The resistors are placed in parallel to give different current ranges.

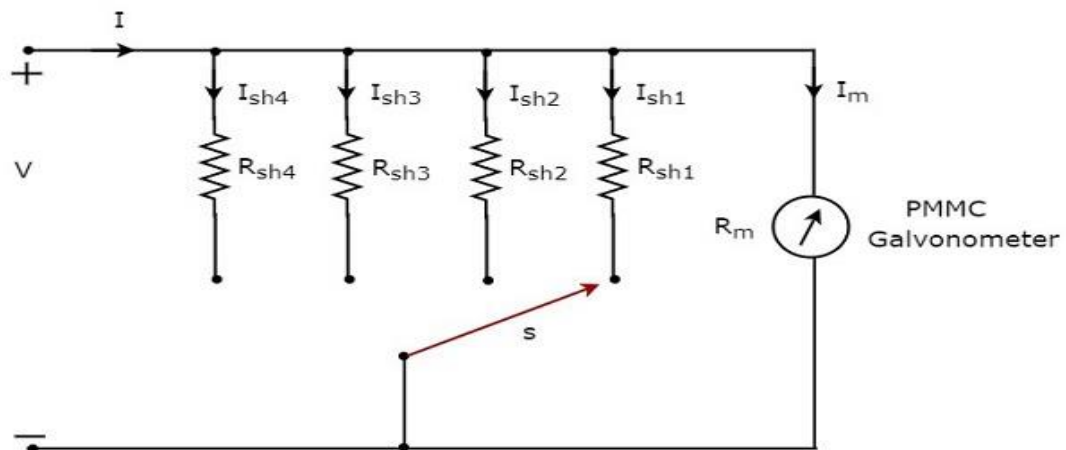

Above figure shows a diagram of multirange ammeter.

- The circuit has 4 shunts  $R_{sh1}$ ,  $R_{sh2}$ ,  $R_{sh3}$  and  $R_{sh4}$  which can be put in parallel with meter movement to give 4 different current ranges  $I_{sh1}$ ,  $I_{sh2}$ ,  $I_{sh3}$  and  $I_{sh4}$ . Let  $m_1$ ,  $m_2$ ,  $m_3$  and  $m_4$  be the shunt multiplying powers for currents  $I_{sh1}$ ,  $I_{sh2}$ ,  $I_{sh3}$  and  $I_{sh4}$ .

$$R_{sh1} = R_m/(m_1-1)$$

$$R_{sh2} = R_m/(m_2-1)$$

$$R_{sh3} = R_m/(m_3-1)$$

$$R_{sh4} = R_m/(m_4-1)$$

- In the Ammeter the multi-position make-before-break switch is used.
- This type of switch is essential in order that meter

movement is not damaged when changing from the current range one to another.

- If we provide an ordinary switch the meter remains without a shunt and it is unprotected and therefore it can be damaged when the range is changed.
- Multirange Ammeters are used for the range from the 1 to 50 A.

## **2.5. AC AMMETER AND MULTIRANGE AMMETERS**

The electrodynamic ammeter uses a moving coil rotating in the field produced by a fixed coil.

- The PMMC movement cannot be used directly for ac measurements since the inertia of PMMC acts as an averager.
- Because A.C. current has zero average value and it produces a torque that has also zero average value, the pointer just vibrates around zero on the scale.
- In order to make ac measurements, a bridge rectifier circuit is combined with PMMC as shown below. Figure

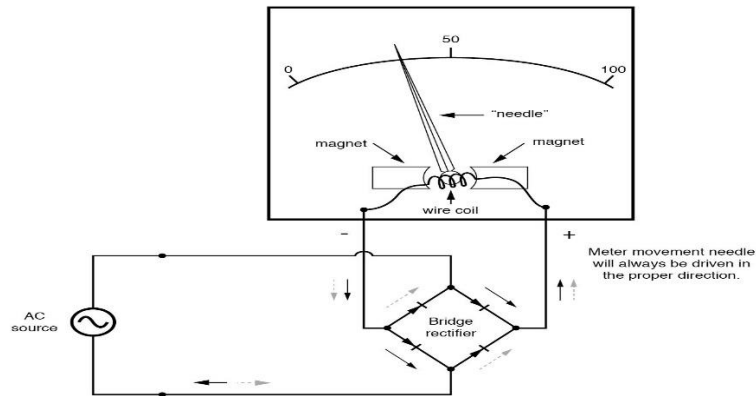

## 2.6 DC VOLTMETER

DC voltmeter is a measuring instrument, which is used to measure the DC voltage across any two points of electric circuit.

If we place a resistor in series with the Permanent Magnet Moving Coil (PMMC) galvanometer, then the entire combination together acts as DC voltmeter.

The series resistance, which is used in DC voltmeter is also called series multiplier resistance or simply, multiplier.

It basically limits the amount of current that flows through galvanometer in order to prevent the meter current from exceeding the full-scale deflection value.

The circuit diagram of DC voltmeter is shown in below figure.

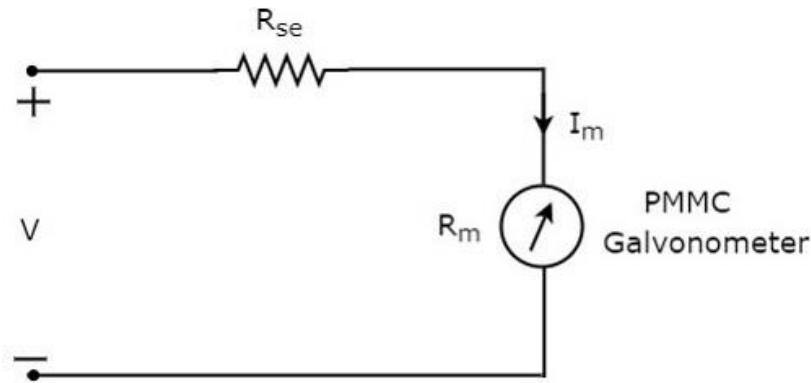

We have to place this DC voltmeter across the two points of an electric circuit, where the DC voltage is to be measured.

Apply **KVL** around the loop of above circuit.

$$V - I_m R_{se} - I_m R_m = 0 \text{----- (Equation 1)}$$

$$\Rightarrow V - I_m R_m = I_m R_s$$

$$\Rightarrow R_{se} = (V - I_m R_m) / I_m$$

$$\Rightarrow R_{se} = V / I_m - R_m \text{----- (Equation 2)}$$

Where,

$R_{se}$  is the series multiplier resistance

$V$  is the full range DC voltage that is to be measured

$I_m$  is the full-scale deflection current

$R_m$  is the internal resistance of galvanometer

The ratio of full range DC voltage that is to be measured,  $V$  and the DC voltage drop across the galvanometer,  $V_m$  is known as multiplying factor,  $m$ . Mathematically, it can be represented as

$$m = V / V_m$$

From Equation 1, we will get the following equation for **full range DC voltage** that is to be measured,  $V$

$$V = I_m R_{se} + I_m R_m \text{----- (Equation 4)}$$

The DC voltage drop across the galvanometer,  $V_m$  is the product of full scale deflection current,  $I_m$  and internal resistance of galvanometer,  $R_m$ . Mathematically, it can be written as  $V_m = I_m R_m$

## 2.7 AC Voltmeter

The instrument, which is used to measure the AC voltage across any two points of electric circuit is called **AC voltmeter**.

If the AC voltmeter consists of rectifier, then it is said to be rectifier based AC voltmeter.

The DC voltmeter measures only DC voltages. If we want to use it for measuring AC voltages, then we have to follow these two steps.

**Step1** – Convert the AC voltage signal into a DC voltage signal by using a rectifier.

**Step2** – Measure the DC or average value of the rectifier's output signal.

We get Rectifier based AC voltmeter, just by including the rectifier circuit to the basic DC voltmeter.

## Types of Rectifier based AC Voltmeters

Following are the **two types** of rectifier based AC voltmeters.

- AC voltmeter using Half Wave Rectifier
- AC voltmeter using Full Wave Rectifier

Now, let us discuss about these two AC voltmeters one by one.

### AC Voltmeter using Half Wave Rectifier

If a Half wave rectifier is connected ahead of DC voltmeter, then that entire combination together is called AC voltmeter using Half wave rectifier.

The block diagram of AC voltmeter using Half wave rectifier is shown in below figure.

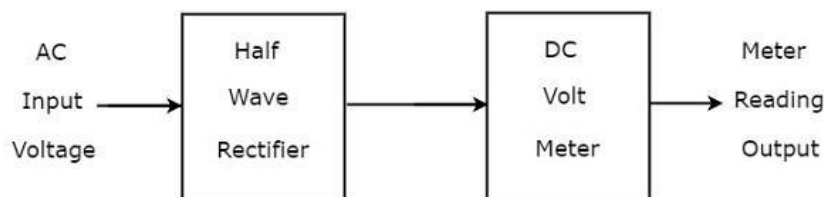

The above block diagram consists of two blocks: half wave rectifier and DC voltmeter. We will get the corresponding circuit diagram, just by replacing each block with the respective component(s) in above block diagram. So, the **circuit diagram** of AC voltmeter using Half wave rectifier will look like as shown in below figure.

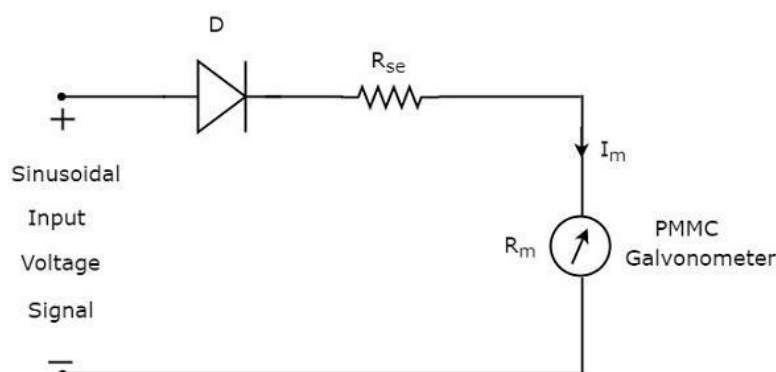

The **rms value** of sinusoidal (AC) input voltage signal is

$$V_{\text{rms}} = \frac{V_m}{\sqrt{2}}$$

$$\Rightarrow V_m = 2\sqrt{V_{rms}}$$

$$\Rightarrow V_m = 1.414V_{rms}$$

Where,

$V_m$  is the maximum value of sinusoidal (AC) input voltage signal.

The **DC** or average value of the Half wave rectifier's output signal is

$$V_{dc} = V_m/\pi$$

Substitute, the value of  $V_m$  in above equation.

$$V_{dc} = 1.414V_{rms}/\pi$$

$$V_{dc} = 0.45V_{rms}$$

Therefore, the AC voltmeter produces an output voltage, which is equal to **0.45** times the rms value of the sinusoidal (AC) input voltage signal.

### AC Voltmeter using Full Wave Rectifier

If a Full wave rectifier is connected ahead of DC voltmeter, then that entire combination together is called AC voltmeter using Full wave rectifier. The **block diagram** of AC voltmeter using Full wave rectifier is shown in below figure.

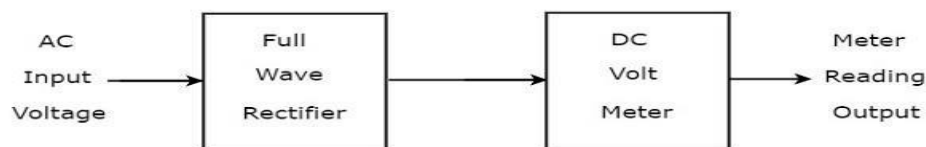

The above block diagram consists of two blocks: full wave rectifier and DC voltmeter. We will get the corresponding circuit diagram just by replacing each block with the respective component(s) in above block diagram.

So, the **circuit diagram** of AC voltmeter using Full wave rectifier will look like as shown in below figure.

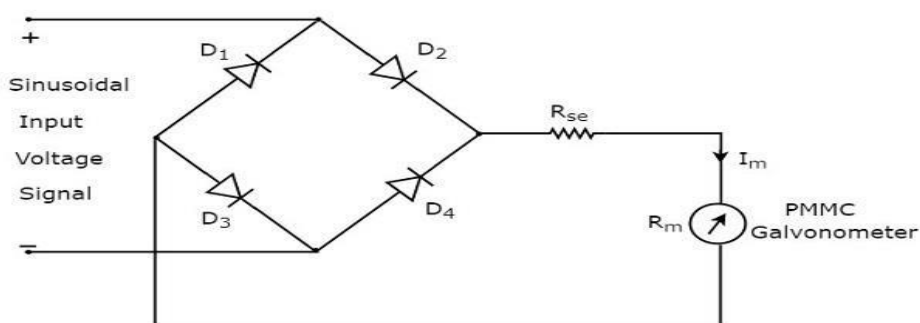

The **rms value** of sinusoidal (AC) input voltage signal is

$$V_{rms} = V_m/\sqrt{2}$$

$$\Rightarrow V_m = \sqrt{2}V_{rms}$$

$$\Rightarrow V_m = 1.414V_{rms}$$

Where,

$V_m$  is the maximum value of sinusoidal (AC) input voltage signal.

The **DC** or average value of the Full wave rectifier's output signal is

$$V_{dc} = 2V_m/\pi$$

**Substitute**, the value of  $V_m$  in above equation

$$V_{dc} = 2 \times 1.414 V_{rms} / \pi$$

$$V_{dc} = 0.9 V_{rms}$$

Therefore, the AC voltmeter produces an output voltage, which is equal to **0.9** times the rms value of the sinusoidal (AC) input voltage signal.

## APPLICATIONS

Voltmeter is used to check the input and output voltage of various equipment such as motors, batteries, medical equipment, electrical panel boards, plastic machinery, electronic devices, etc

## 2.8-BASIC OPERATION OF OHMMETER

The instrument, which is used to measure the value of resistance between any two points in an electric circuit is called ohmmeter.

It can also be used to find the value of an unknown resistor. The units of resistance are ohm and the measuring instrument is meter.

So, the word "ohmmeter" is obtained by combining the words "ohm" and "meter".

## TYPES OF OHMMETERS

Following are the **two types** of ohmmeters.

- Series Ohmmeter
- Shunt Ohmmeter

Now, let us discuss about these two types of ohmmeters one by one.

### SERIES OHMMETER

If the resistor's value is unknown and has to be measured by placing it in series with the ohmmeter, then that ohmmeter is called series ohmmeter. The circuit diagram of series ohmmeter is shown in below figure.

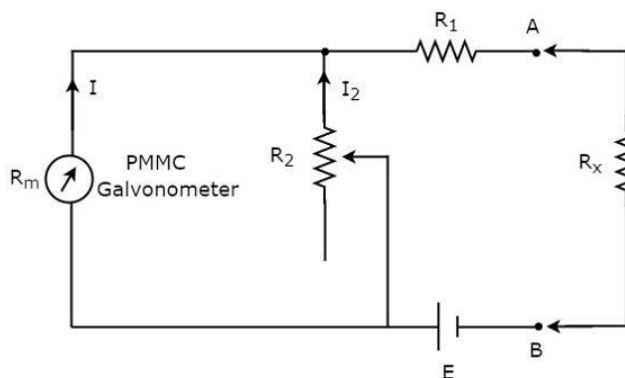

The part of the circuit, which is left side of the terminals A & B is **series ohmmeter**.

So, we can measure the value of unknown resistance by placing it to the right side of terminals A & B.

## SHUNT OHMMETER

If the resistor's value is unknown and to be measured by placing it in parallel (shunt) with the ohmmeter, then that ohmmeter is called shunt ohmmeter. The circuit diagram of shunt ohmmeter is shown in below figure.

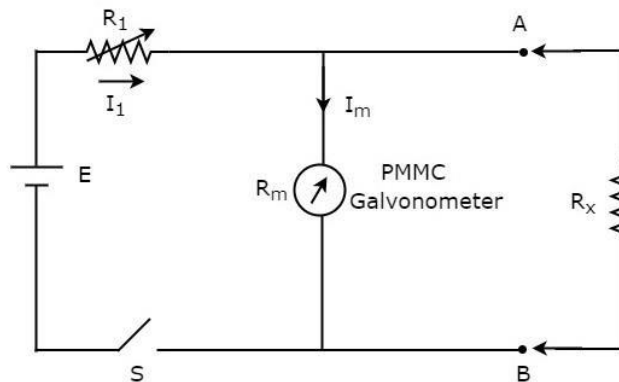

The part of the circuit, which is left side of the terminals A & B is shunt ohmmeter.

So, we can measure the value of unknown resistance by placing it to the right side of terminals A & B.

## 2.9 ANALOG MULTIMETER

As the name implies, a *multimeter* is a device that can be used to measure multiple quantities, i.e., when a single device is used to measure multiple quantities, the device is called *multimeter*. On the basis of output representation, there are two types of multimeters –

- Analog multimeter
- Digital multimeter

### ANALOG MULTIMETER

An analog *multimeter* is a permanent magnet moving coil (PMMC) meter type measuring instrument.

It works on the principle of d'Arsonval galvanometer.

The analog multimeter has an analog display that uses the deflection of a pointer on the scale to indicate the level of measurement being made.

The pointer deflects from its initial position increasingly as the measuring quantity increases.





## WORKING OF ANALOG MULTIMETER

Since, the analog multimeter is a PMMC types instrument, so when a current is passed through its coil, the coil moves in a magnetic field produced by the permanent magnet. A pointer is attached with the coil. When current flows in the coil, a deflecting torque acts on the coil that will rotate it by an angle, so the pointer moves over a scale. A pair of hairsprings is attached to the spindle to provide the controlling torque.

## ANALOG MULTIMETER MEASURING QUANTITIES

A typical analog multimeter can measure following electrical quantities –

- DC Voltage
- AC Voltage
- DC Current
- Resistance

The analog multimeter acts as an *ammeter* with a low series resistance to measure direct current.

For high currents measurement, a shunt resistor is connected in parallel with the galvanometer.

With the shunt resistor, an analog multimeter can measure currents in the ranges of milli-amperes or amperes.

By adding a multiplier resistor an analog multimeter becomes a *voltmeter* and can be used for the measurement of DC voltage in the ranges of milli-volts or kilo volts.

By adding a battery and a network of resistors, the analog multimeter can work as an *ohmmeter*.

By changing the value of shunt resistance in resistor network, different values of resistances can be measured.

By adding a rectifier unit in the analog multimeter circuit, the AC voltages and currents can also be measured.

## BLOCK DIAGRAM OF ANALOG MULTIMETER.

Here, two switches S1 and S2 are used to select the desired meter. It also has a rotary range-selector switch to choose a particular range of current, voltage and resistance.

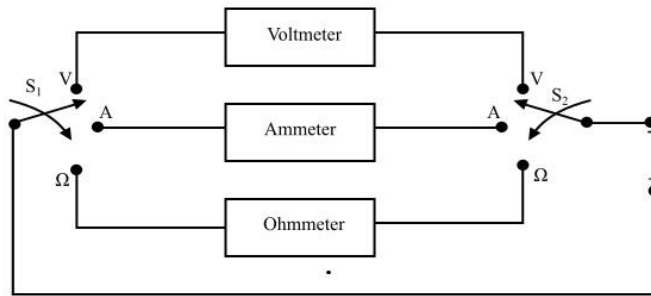

## Operation of Analog Multimeter

The analog multimeter is very easy to use.

With the knowledge of how to make voltage, current and resistance measurements, it is only necessary to know how to use the analog multimeter.

For the measurement of current and voltage, there is no need of batteries in the analog multimeter.

But, if resistance is to be measured, batteries need to be installed in the multimeter.

### ADVANTAGES OF ANALOG MULTIMETER

- It gives the continuous reading, thus a sudden change in signal can be detected which is not possible with digital multimeter.
- Analog multimeter are very cheap.
- All measurement can be made using a single meter only.

### Disadvantages of Analog Multimeter

- They are bulky and larger sized.
- Multiple scales, these can cause confusion.
- Low input resistance.
- Analog multimeters do not have auto-polarity function. Therefore, it is necessary to connect probes correctly.
- Less accurate than a digital multimeter.

## 2.10 Q-METER

**Definition:** The instrument which measures the storage factor or quality factor of the electrical circuit at radio frequencies, such type of device is known as the Q-meter.

The quality factor is one of the parameters of the oscillatory system, which shows the relation between the storage and dissipated energy.

### WORKING PRINCIPLE OF Q METER

The Q meter works on series resonant. The resonance is the condition exists in the circuit when their inductance and capacitive reactance are of equal magnitude. They induce

energy which is oscillating between the electric and magnetic field of the capacitor and inductor respectively.

The Q-meter is based on the characteristic of the resistance, inductance and capacitance of the resonant series circuit.

The figure below shows a coil of resistance, inductance and capacitance connected in series with the circuit.

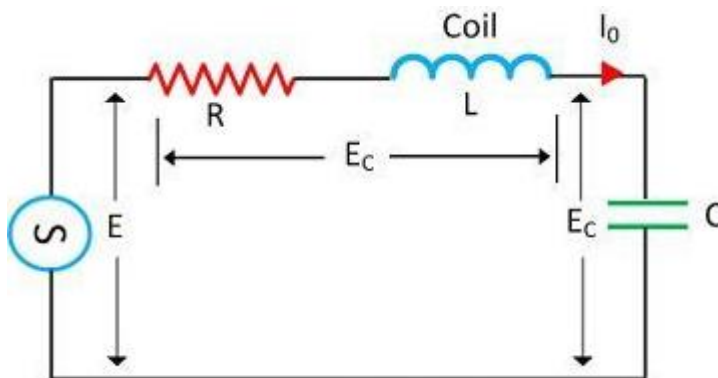

Application of Q- meter:

- (i) Measurement of Q
- (ii) Measurement of Inductance
- (iii) Measurement of effective resistance.
- (iv) Measurement of self-capacitance.
- (v) Measurement of Bandwidth.

## CHAPTER-3

### DIGITAL INSTRUMENTS

#### Ramp-type DVM

- Principle of DVM

The principle of operation of the ramp-type DVM is based on the measurements of the time it takes for linear ramp voltage to rise from 0 V to the level of input voltage, or decrease from the level of the input voltage to zero. This interval of time is measured with an electronic time interval counter, and the count is displayed as a number of digits.

Fig

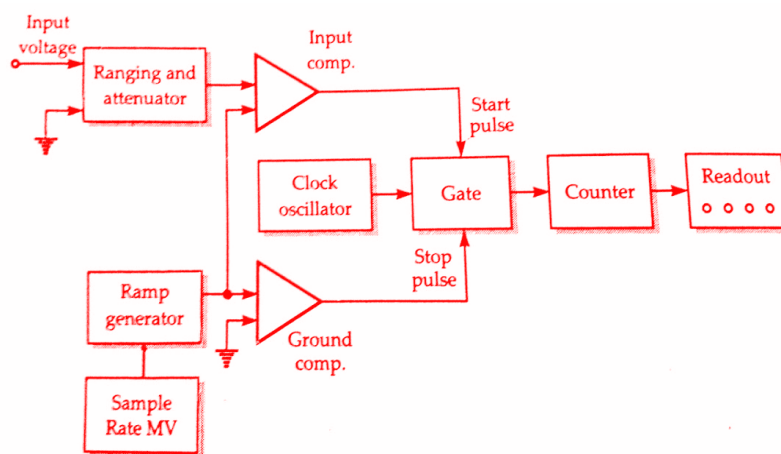

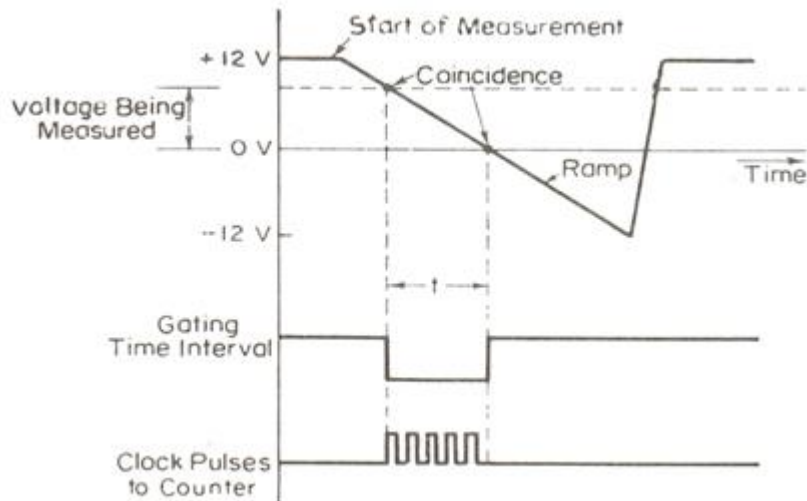

(WAVE FORM DIAGRAM OF DVM)

- CONSTRUCTION OF DVM

- The ramp type of DVM consists of ranging and attenuator circuit.
- It consists of an input comparator and ground comparator.
- It consists of ramp generator and sample rate multivibrator.
- It consists of clock oscillator and a gate circuit.
- It also consists of a counter and a display device (readout)

- WORKING OF DVM

- At the start of the measuring cycle, a ramp voltage is initiated; this voltage can be positive going or negative going. The negative going ramp, shown in the above figure is continuously compared with the unknown input-voltage.
- At the instant that the ramp voltage equals the unknown voltage the input comparator, generates a pulse which opens a gate [see fig.] which is known as start pulse.

- The ramp voltage continues to decrease with time until it finally reaches 0 V [or ground potential] at that instant ground comparator generates an output pulses which closes the gate is known as stop pulse.
- An oscillator generates clock pulses which are allowed to pass through the gate to a number of decade counting units [DCUs] which totalise the number of pulses passed through the gate.
- The decimal number, displayed by the display device is a measure of the magnitude of the input voltage.
- The sample-rate MV circuit provides an initiating pulse for the ramp generator to start its next ramp voltage.
- At the same time, a reset pulse is generated which returns all the DCUs to their zero state, removing the display momentarily from the display.

### Characteristics of Digital Meters

Following are the few specifications which characterize digital meters:

- 1. Resolution-** It is defined as the number of digit positions or simply the number of digits used in a meter.

If a number of full digits is n, then resolution,

$$R=1/10^n$$

For n=4  $R=1/10^4=0.0001$  or 0.01%.

A three-digit display on the digital meter for 0-1 V range will be able to indicate from 000 to 999mV, with smallest increment (resolution) of 1mV.

**2. Sensitivity**-It is the smallest change in input which a digital meter is able to detect. Thus, it is the full-scale value of the lowest voltage range multiplied by the resolution of the meter .In other words,

$$\text{Sensitivity}(S) = (f_s)_{\min} * R$$

Where,  $(f_s)$ =Lowest full-scale value of digital meter

$R$ =Resolution is decimal.

## DIGITAL MULTIMETER

### Definition:

- The electronic measuring device which is capable of measuring multiple electrical parameters and display it digitally is called as digital multimeter.
- It can measure both AC and DC.

### Block diagram of a digital multimeter (DMM)

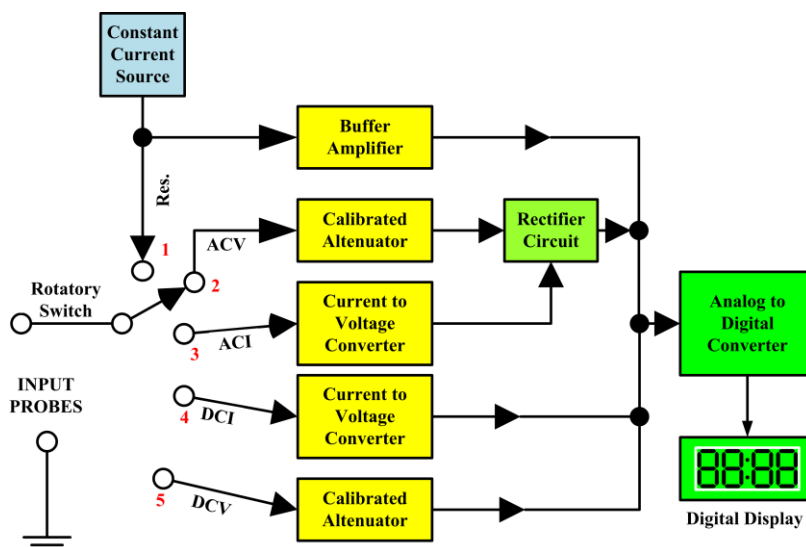

## Construction:

- Digital multimeter consists of a rotary switch and constant current source.
- It consists of calibrated attenuator and current to voltage converters.
- It consists of buffer amplifier and rectifier circuit.
- It consists of analog to digital converter and display device.

## Working of DMM

- First of all, the rotary switch is set at the parameter position which is to be measured.
- When the switch is set at “Res” as shown in figure then a connection is made to constant current source.
- Then the test resistor is connected to probe for measurement and current from current source flows through buffer amplifier, analog to digital converter .
- The analog to digital converter gives



corresponding digital value of the inputted resistor.

- When switch is set for alternating voltage measurement the input current passes through calibrated attenuator, rectifier circuit, ADC, display device.
- Attenuator decreases strength of the input signal and rectifier converts ac to dc.
- In this way the DMM works as per the setting of rotary switch.

## **DIGITAL FREQUENCY METER**

Definition: The electronics device which measure frequency of a signal and display it digitally is called as digital frequency meter.

### **Principle of Digital frequency meter**

- The digital frequency meter works on the principle of conversion of sinusoidal signal into continuous pulses.
- It has very close relationship with measurement of time.

## Diagram of digital frequency meter Fig.

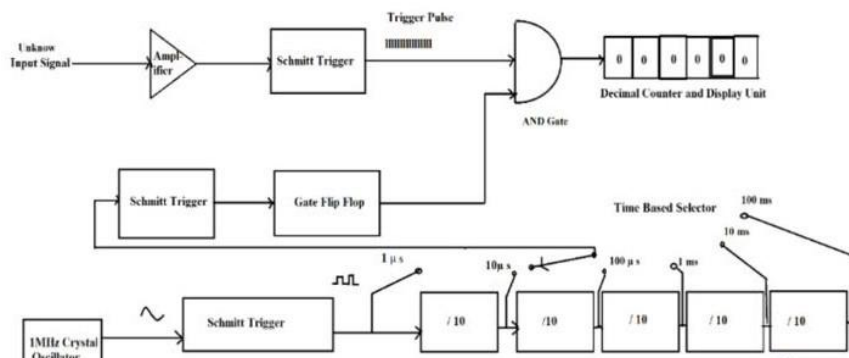

### Construction of Digital frequency meter:

- Digital frequency meter consists of amplifier and Schmitt trigger circuit.
- It also consists of Flip flop and crystal oscillator.
- It consists of Time base selector, frequency divider network, decimal counter and display unit.

### Working of Digital frequency meter

- When the unknown input signal is applied to the amplifier it amplifies the signal and feed it to the Schmitt trigger.
- The Schmitt trigger converts the amplified input signal into its corresponding pulses and give it to the AND Gate.
- When Schmitt trigger output reaches at gate, the output from flip flop also reaches at gate.
- The flip flop output provides precise time period for which the counter counts the number of pulses which is displayed as frequency of the input signal.

### Measurement of Time (Period Measurement)

- In some cases, it is necessary to measure the time

period rather than the frequency.

- This is especially true in the measurement of frequency in the low frequency range.
- To obtain good accuracy at low frequency, we should take measurements of the period, rather than make direct frequency measurements.
- The circuit used for measuring frequency (Fig.) can be used for the measurement of time period if the counted signal and gating signal are interchanged.
- Figure shows the circuit for measurement of time period.
- The gating signal is derived from the unknown input signal, which now controls the enabling and disabling of the main gate.
- The number of pulses which occur during one period of the unknown signal are counted and displayed by the decade counting assemblies.
- The only disadvantage is that for measuring the frequency in the low frequency range, the operator has to calculate the frequency from the time by using the equation  $f = 1/T$ .

## **DIGITAL TACHOMETER**

- The technique employed in measuring the speed of a rotating shaft is similar to the technique used in a conventional frequency counter, except that the selection of the gate period is in accordance with the rpm calibration.
- Let us assume that the rpm of a rotating shaft is R.
- Let P be the number of pulses produced by the pickup for one revolution of the shaft.
- Therefore, in one minute the number of pulses from the pickup is  $R \times P$ .

- Then, the-frequency of the signal from the pickup is  $(R \times P)/60$ .
- Now, if the gate period is  $G$  s the pulses counted are  $(R \times P \times G)/60$ .
- In order to get the direct reading in rpm, the number of pulses to be counted by the counter is  $R$ .
- So we select the gate period as  $60/ P$ , and the counter counts  $(R \times P \times 60)/ 60P = R$  pulses and we can read the rpm of the rotating shaft directly.
- So, the relation between the gate period and the number of pulses produced by the pickup is  $G = 60/P$ .
- If we fix the gate period as one second ( $G = 1$  s), then the revolution pickup must be capable of producing 60 pulses per revolution.
- Figure shows a schematic diagram of a digital tachometer.

## **AUTOMATION**

- 1. Automatic Polarity Indication:** The polarity indication is generally obtained from the information in the ADC. For integrating ADCs, only the polarity of the integrated signal is of importance. The polarity should thus be measured at the very end of the integration period (see Fig. 6.21). As the length of the integration period is determined by counting a number of clock pulses, it is logical to use the last count or some of the last counts to start the polarity measurement. The output of the integrator is then used to set the polarity flip-flop, the output of which

is stored in memory until the next measurement is made.

**2. Automatic Ranging:** The object of automatic ranging is to get a reading with optimum resolution under all circumstances (e.g. 170 m V should be displayed as 170.0 and not as 0.170). Let us take the example of a 3Yz digit display, i.e. one with a maximum reading of 1999. This maximum means that any higher value must be reduced by a factor of 10 before it can be displayed (e.g. 201 m V as 0201). On the other hand, any value below 0200 can be displayed with one decade more resolution (e.g. 195 mV as 195.0). In other words, if the display does not reach a value of 0200, the instrument should automatically be switched to a more sensitive range, and if a value of higher than 1999 is offered, the next less sensitive range must be selected.

## **DIGITAL LCR METER**

This type of meter is used to measure the resistance, inductance, capacitance and dissipation factor. The desired function can be selected by using a rotary switch. The various ranges available are

- 1) 200 $\mu$ H/pF/ $\Omega$ ,
- 2) 2000 $\mu$ H/pF/ $\Omega$ ,
- 3) 200mH/nF/k $\Omega$  ,
- 4) 200mH/nF/k $\Omega$  ,
- 5) 2H/ $\mu$ F/M $\Omega$

With the help of this instrument, the following ranges of various measurements can be made Resistance:

From 200  $\Omega$  to 20 M  $\Omega$ ;  
Inductance: From 2000  $\mu\text{H}$  to 2 H;  
Capacitance: From 2000 pF to 2  $\mu\text{F}$

## CHAPTER -4

### OSCILLOSCOPE

Discuss the basic principle of Oscilloscope.

It is a device that allows the amplitude of electrical signal whether voltage, current or power to be displayed a function of time.

- It is basically an electron beam voltmeter
- It depends on the movement of an electron beam to impinge on phosphor screen, which produces a visible spot.
- When the electron beam is deflected by some means in two axes (x & y) the visible spot can be used to create a two dimensional graph .
- Oscilloscope is capable of displaying events that take place over periods of microseconds and nanosecond.

Discuss the Block Diagram of Oscilloscope & Simple CRO.

- The block diagram of simple CRO is as shown in figure below.

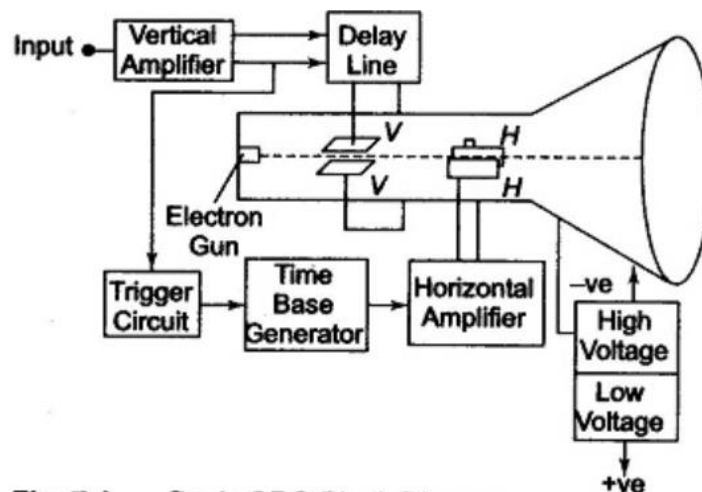

- Here the Oscilloscopes are used to observe the change of an electrical signal over time, such that voltage and time describe a shape which is

continuously graphed against a calibrated scale.

- The observed waveform can be analyzed for such properties as amplitude, frequency, rise time, time interval, distortion and others.
- Modern digital instruments may calculate and display these properties directly.
- Originally, calculation of these values required manually measuring the waveform against the scales built into the screen of the instrument.
- The oscilloscope can be adjusted so that repetitive signals can be observed as a continuous shape on the screen.
- A storage oscilloscope allows single events to be captured by the instrument and displayed for a relatively long time, allowing human observation of events too fast to be directly perceptible.
- Oscilloscopes are used in the sciences, medicine, engineering, and telecommunications industry.
- General-purpose instruments are used for maintenance of electronic equipment and laboratory work.
- Special-purpose oscilloscopes may be used for such purposes as analyzing an automotive ignition system or to display the waveform of the heartbeat as an electrocardiogram.



## Dual Trace CRO:

**Definition:** The oscilloscope which is capable to display two signals at a time on a screen having single electron gun is called as dual trace oscilloscope.

### Diagram:

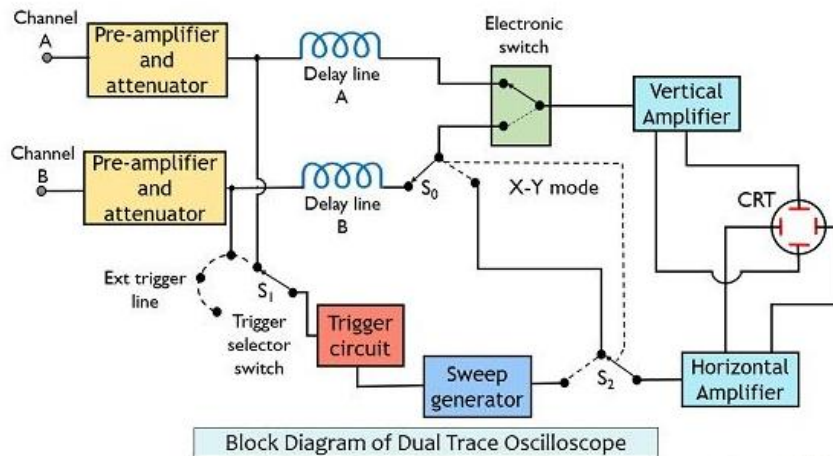

### Construction:

- It consists of two attenuator which conditions the input signal.
- It consists of two preamplifier which.
- Amplifies the signal coming from attempt.
- It consists of an electronic switch and vertical amplifier.

### WORKING

- In this type of oscilloscope both the input signal are applied simultaneously but it has one electron gun.
- Both the signals are fed to the electronic switch through preamplifier.
- The electronic switch connects the signals to the vertical amplifier by two ways.
- One way of connecting the signal to the vertical amplifier expects is alternate made of operation, but it is not suitable for low frequency signals.
- Another way of connecting the signal to the vertical amplifier is chap mode of operation.

**Lissajous Pattern :-**

- A set of patterns obtained when two sinusoidal waves are applied to the both horizontal and vertical deflecting plates (x&y) of CRO simultaneously. Are called as lissajous pattern.
- These patterns are as per the name of scientist. Jauls Antonmene lissajous .
- The shape of the Lissajous pattern depends on the frequency and phase relationship of the two-sine wave.

**phase measurement :-****Procedure :**

- To measure the phase angle between two sinusoidal signal.
- The signal is fed to Y-plate and another signal is feed to the x-plates:
- If two signals are in phase, the display is as shown in the figure:
- If phase angle is  $180^0$  Then figure is

Figure:

- If phase angle is  $90^0$  Then the figure is

Figure:

Phase angle in between 0 and 90 or 270 and 360 Then the figure:

**Frequency Measurement :-**

- Both the signal is applied to X &Y input simultaneously.
- Oscilloscope's internal sweep and sync. Control is switch off.

**Application of CRO:-**

- 1) Tracing of Signal
- 2) Measurement of amplitude of signal
- 3) Comparison of phase & frequency of signal.
- 4) Measurement of capacitance and inductance.
- 5) In television Radar.
- 6) For engine pressure analysis.
- 7) For studying heart beats nervous reactions.

## DIGITAL STORAGE OSCILLOSCOPE

### Construction

- It consists of Alternator writer amplifier & sample and hold circuit.
- It consists of ADC, trigger CRT and memory.
- It consists control logic unit, DAC and horizontal Amplifier.

### Diagram:

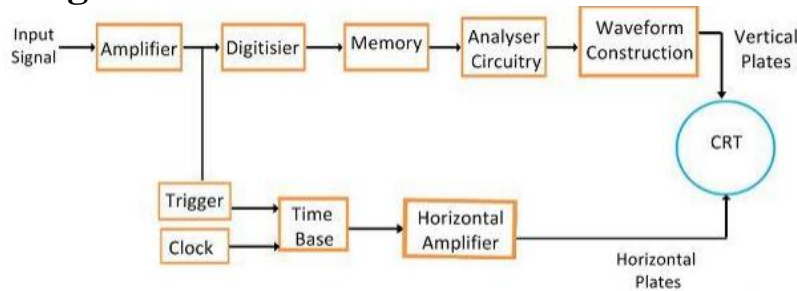

### Working :-

- The Signal is amplified and attenuated and given to the sample and hold circuit and trigger circuit.
- The output of sample and hold circuit is given to the Analog to-Digital converter which converts our analog signal into digital data.
- This digital data is given to memory which is given to vertical deflection amplifier through D/A.
- The Control logic also gives another signal to CRT through horizontal deflection amplifier through D/A.
- By receiving both the signal CRT displays.

### ADVANTAGES :-

- Infinite storage time.
- Easy to operate.
- Signal processing is possible.
- A number of traces can be stored.
- Display of work from is possible by retriggering.

### Applications

- It can be used to measurement AC & DC.

- It can be used to measure frequency, time period, time interval between two signals.
- It is used to give visual representation for a target of rader.

### **High Frequency Oscilloscope:-**

- The type of oscilloscope which is capable of displaying signal of frequency more than 300 KHz are called as HF oscilloscope.
- The HF oscilloscope can display up to 500 MHz signal.
- The HF oscilloscope differ in their internal construction from LF oscilloscope by their special HF CRTS and high frequency amplifiers.
- Electron beam
- The HF oscilloscope consists of series of vertical deflection plates.

## CHAPTER -5

### BRIDGES

#### 5.1 TYPES OF BRIDGES

There are two types of bridge (i) Dc bridges.

(ii) Ac bridges.

#### 5.2 WHEATSTONE BRIDGE

The simplest form of bridge is for the purpose of measuring resistance and is called as wheatstone brodge.

Let  $R_1$ ,  $R_2$ , and  $R_3$  are standard resistors.

$R_4$  = Unknown resistors .

For a balance bridge condition.

$$V_A = V_B \dots\dots\dots (1)$$

$$I_1 = I_3 \quad \text{And} \quad I_2 = I_4$$

$$I_1 = I_3 = \frac{V}{R_1+R_3} \dots\dots\dots(2)$$

$$\text{And} \quad I_2 = I_4 = \frac{V}{R_2+R_4} \dots\dots\dots(3)$$

From equation (1)  $V_A = V_B$

$$\Rightarrow I_1 R_1 = I_2 R_2$$

$$\Rightarrow \frac{V R_1}{R_1+R_3} = \frac{V R_2}{R_2+R_4}$$

$$\Rightarrow \frac{R_1}{R_1+R_3} = \frac{R_2}{R_2+R_4}$$

$$\Rightarrow R_1 R_4 = R_2 R_3$$

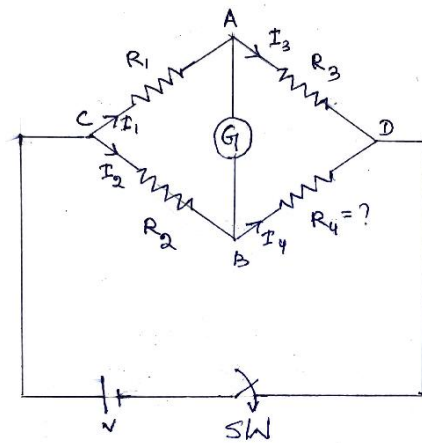

WHEATSTONE BRIDGE

Diagram

### 5.3 MEASUREMENT OF INDUCTANCE BY MAXWELL'S BRIDGE

This bridge circuit measures an inductance by comparison with a variable standard self-inductance.

The connections and the phasor diagrams for balance conditions are shown in fig:

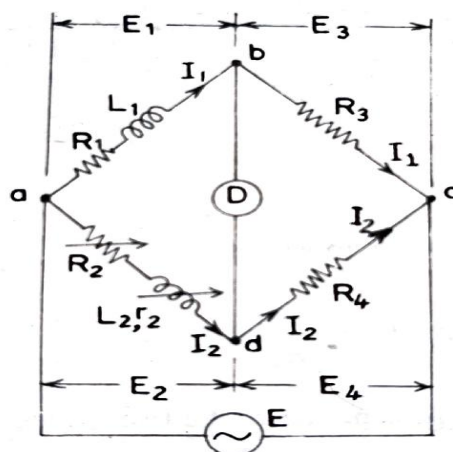

Let  $L_1$  = unknown inductance of resistance  $R_1$ .

$L_2$  = Variable inductance of fixed resistance  $r_2$

$R_2$  = variable resistance connected in series with inductor  
 $L_2$

$R_3, R_4$  = known non-inductive resistances.

The bridge balance equation is

$$Z_1 Z_4 = Z_2 Z_3$$

$$Z_1 = Z_2 Z_3 / Z_4 \dots \dots \dots (1)$$

Where  $Z_1 = R_1 + j\omega L_1$

$$Z_2 = R_2 + r_2 + j\omega L_2$$

$$Z_3 = R_3$$

$$Z_4 = R_4$$

Putting all values of in equation (1)

$$\text{We get } R_1 + j\omega L_1 = (R_2 + r_2 + j\omega L_2)(R_3) / R_4$$

$$R_1 R_4 + j\omega L_1 R_4 = R_2 R_3 + r_2 R_3 + j\omega L_2 R_3$$

By comparing real and imaginary parts we get:

$$R_1 R_4 = R_2 R_3 + r_2 R_3 \dots \dots \dots \text{Equation (2)}$$

$$L_1 R_4 = L_2 R_3 \dots \dots \dots \text{Equation (3)}$$

From equation (3) we can easily get the value of unknown inductor  $L_1$  since values of  $L_2, R_4, R_3$  is known to us.

## Advantages of Maxwell's Bridge

- (1) The frequency does not appear in the final expression of both equations hence it is independent of frequency.
- (2) Maxwell's inductor capacitance bridge is very useful for the wide range of measurement of **inductor** at audio frequencies.

## Disadvantages of Maxwell's Bridge

- (1) The variable standard capacitor is very expensive.
- (2) The bridge is limited to measurement of low quality coils ( $1 < Q < 10$ ) and it is also unsuitable for low value of  $Q$  (i.e.  $Q < 1$ ) from this we conclude that a Maxwell bridge is used suitable only for medium  $Q$  coils.

The above all limitations are overcome by the modified bridge which is known as Hay's bridge which does not use an electrical resistance in parallel with the capacitor.

### 5.3 MEASUREMENT OF SELF-INDUCTANCE BY HAY'S BRIDGE

A Hay's bridge is modified Maxwell bridge, now question arises here in our mind that where we need to do modification. In order to understand this, let us consider the connection diagram given below:

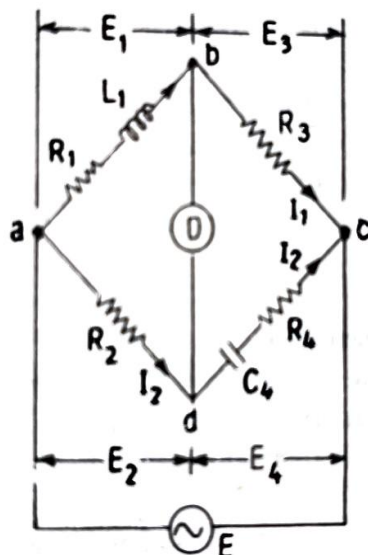

Let  $L_1$  = unknown inductance of resistance  $R_1$ .

$R_2, R_3, R_4$  = Known non-inductive resistance.



$C_4$  = Standard capacitor.

At Balance condition  $Z_1Z_4 = Z_2Z_3$  ..... Equation (1)

Where  $Z_1 = R_1 + j\omega L_1$

$$Z_2 = R_2$$

$$Z_3 = R_3$$

$$Z_4 = R_4 - j/\omega C_4$$

By putting all the values of  $Z_1, Z_2, Z_3, Z_4$  in equation (1) we get

$$(R_1 + j\omega L_1) (R_4 - j/\omega C_4) = R_2R_3$$

Or  $R_1R_4 + L_1/C_4 + j\omega L_1R_4 - jR_1/\omega C_4 = R_2R_3$

Separating the real and imaginary parts we get:

$$R_1R_4 + L_1/C_4 = R_2R_3 \text{ ..... Equation (2)}$$

$$\text{and } L_1R_4 = R_1/\omega^2 C_4 R_4 \text{ ..... Equation (3)}$$

By solving equation (2) and (3) we get

$$L_1 = R_2R_3C_4 / (1 + \omega^2 C_4^2 R_4^2) \text{ ..... Equation (5)}$$

$$R_1 = \omega^2 R_2R_3R_4C_4^2 / (1 + \omega^2 C_4^2 R_4^2) \text{ ..... Equation (6)}$$

From the equation (5) and (6) it is clear that inductance value depends on frequency of the source of supply to the bridge

### Hay's Bridge Applications

- Before we introduce Hay's bridge let us recall the limitations of Maxwell Bridge, in order to understand what is the necessity of Hay's bridge applications.
- Maxwell bridge is only suitable for measuring medium quality factor coils however it is not suitable for measuring high quality factor ( $Q > 10$ ). In order to overcome from this limitation we need to do modification in Maxwell bridge so that it will become

suitable for measuring Q factor over a wide range.

- This modified Maxwell bridge is known as Hay's bridge.

### Advantages of Hay's Bridge

(1) The bridge gives very simple expression for the calculation of unknown inductor of high value. The Hay's bridge requires low value of  $r_4$  while Maxwell bridge requires high value of  $r_4$ . Now let us analyze why should put low value of  $r_4$  in this bridge: Consider the expression of quality factor, As  $r_4$  presents in the denominator hence for high quality factor,  $r_4$  must be small.

### Disadvantages of Hay's Bridge

Hay's bridge is not suitable for

measurement of quality factor ( $Q < 10$ ) for

$Q < 10$  we should use Maxwell bridge.

## 5.4 Measurement of capacitance by Schering's Bridge

Diagram:

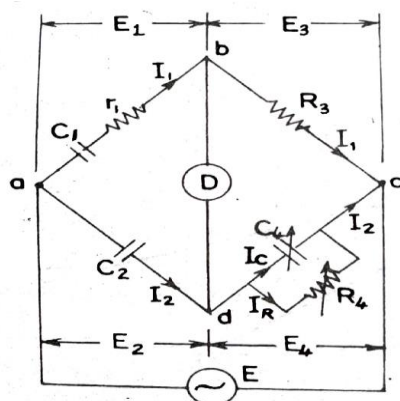

Let  $C_1$  = Unknown capacitor whose capacitance is to be determined.

$R_1$  = A series resistance represents loss in capacitor  $C_1$ .

$C_2$  = A loss free standard capacitor.

$R_3$  = A non-inductive resistor.

$C_4$  = A variable capacitor.

$R_4$  = A variable non-inductive resistor in parallel with capacitor  $C_4$ .

At Balance condition.

$$Z_1 Z_4 = Z_2 Z_3 \dots\dots\dots \text{Equation (1)}$$

$$\text{Where } Z_1 = R_1 + 1/j\omega C_1$$

$$Z_2 = 1/j\omega C_2$$

$$Z_3 = R_3$$

$$Z_4 = R_4/(1 + j\omega C_4 R_4)$$

By putting all the values of  $Z_1, Z_2, Z_3, Z_4$  in equation (1) we get

$$(R_1 + 1/j\omega C_1)(R_4/(1 + j\omega C_4 R_4)) = R_3/j\omega C_2$$

$$\text{Or } (R_1 + 1/j\omega C_1) R_4 = (R_3/j\omega C_2)(1 + j\omega C_4 R_4)$$

$$\text{Or } R_1 R_4 - jR_4/\omega C_2 = jR_3/\omega C_2 + R_3 R_4 C_4$$

Equating the real and imaginary terms we get

$$R_1 = R_3 C_4/C_2 \dots\dots\dots \text{Equation (2)}$$

$$C_1 = C_2 (R_4/R_3) \dots\dots\dots \text{Equation (3)}$$

From equation (3) we can easily find the value of unknown capacitor.

## 5.4-MEASUREMENT OF CAPACITANCE BY DESAUTY'S BRIDGE

Diagram:

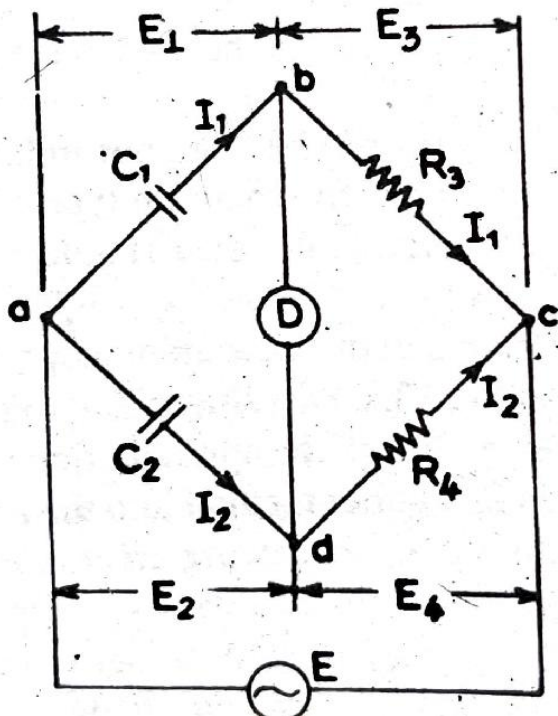

Let  $C_1$  = Unknown capacitor whose capacitance is to be determined.

$C_2$  = A standard capacitor.

$R_3, R_4$  = non-inductive resistors.

At Balance condition

$$Z_1 Z_4 = Z_2 Z_3 \dots\dots\dots \text{Equation (1)}$$

Where  $Z_1 = 1/j\omega C_1$

$$Z_2 = 1/j\omega C_2$$

$$Z_3 = R_3$$

$$Z_4 = R_4$$

By putting all the values of  $Z_1, Z_2, Z_3, Z_4$  in equation (1) we get

$$(1/j\omega C_1) R_4 = (1/j\omega C_2) R_3$$

$$\text{Or } C_1 = C_2 R_4 / R_3 \dots\dots\dots \text{Equation(2)}$$

From equation (2) we can get value of unknown capacitor very easily.

## **5.5 WORKING OF Q METER.**

**Def :-**The instrument which is designed to measure electrical properties of coils and capacitors is called as Q-met.

**Principle :-** The Principle of the Q-meter is based on series resonance, the voltage drop across the coil or cap

### **Construction:**

- It consists of a wide range of oscillator which is used as power supply of the circuit.
- It also consists of a shunt resistor  $R_{sh}$  inductor  $L$ , resonating capacitor  $C_R$ .
- It consists of electronic voltmeter calibrated in Q-value & thermocouple voltmeter.

### **Working:**

- Quality factor is nothing the ratio of reactance to resistance. ( $X_L/R$ ).
- When a fixed voltage is applied to the circuit, voltmeter across the capacitor can be calibrated to read directly.
- Where  $X_L =$  Inductive reactance.

$X_c =$  capacitive reactance

$R =$  Coil resistance.

$I =$  circuit current.

$V_L =$  Inductive voltage

$V_c =$  Capacitor voltage

At resonance  $X_L = X_C$

$$V_L = IX_L$$

$$V_C = IX_C$$

$$V = IR$$

Therefore  $Q = X_L/R = X_C/R = 1/\omega CR = V_C/V \dots \dots (1)$

- In the above equation if  $V$  is kept constant, the voltage across the capacitor can be measured by voltmeter calibrated to read directly in terms of  $Q$ .

## 5.6 LCR METER & ITS MEASUREMENTS

**Def:** It is defined as the electronic measuring instrument which can measure values of inductances (L), Capacitance (c) & Resistance (R) directly.

### CKT Diagram

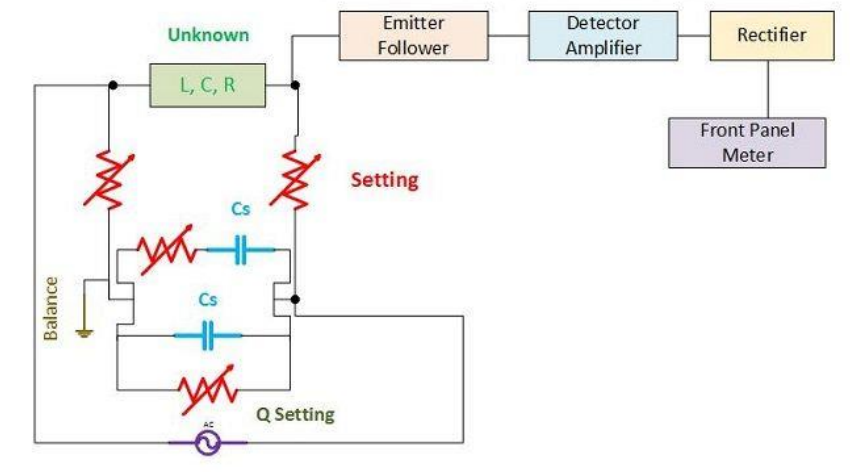

### **Construction**

- It consists of a permanent magnet moving coil instrument.
- The scale of the meter is calibrated in terms of R, L, C.
- It consists of an emitter follower circuits.
- It consists of a detector amplifier.
- It consists of a rectifier.
- It also consists of Wheatstone bridge.

### **WORKING**

- When the test component is set at the test terminal the current passes through it.
- The bridge is adjusted in null position in order to balance it completely.
- The output from the bridge is fed to emitter follower circuit.
- The output from emitter follower circuit is given as an input to detector amplifier.
- The detector amplifier is used in order to prevent the fall of voltage level during measurement process.
- The **rectifier** is used in the circuit to convert the AC signal into DC signal.

- At last the DC signal is converted to digital data which is shown in the display device.

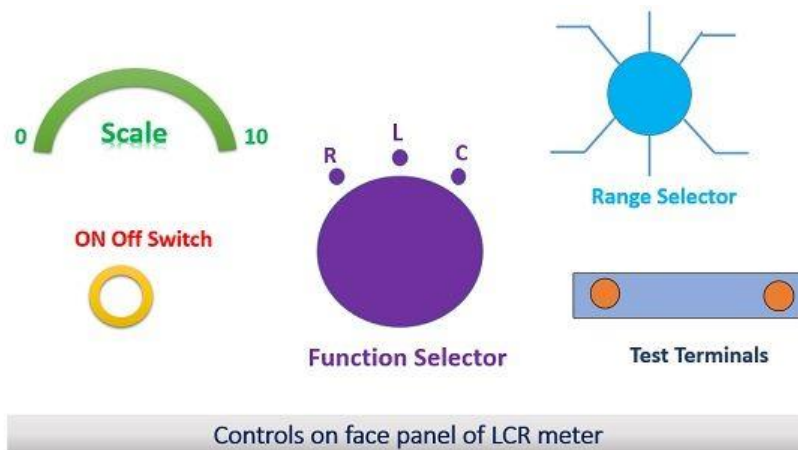

## CHAPTER-6

### TRANSDUCERS AND SENSORS

Definition of transducers: The device which transforms the energy of the process variable to an output of some other type of energy which is able to operate some control device is called as transducer.

Definition of Sensor: the device which sense the condition, state or value of the process variable and produce an output which reflects this condition, state or variable.

Method of Selecting transducers:

- There are many ways for measurement of a physical quantity. While *selection of transducers*.
- How to select a transducer for a particular application, following points should be kept in the mind.
- Unfortunately most transducers are not sensitive to just one quantity. If measurements are to be made under conditions where there is likelihood of two or more input quantities influencing the transducer.
- it is desirable to select a transducer which is sensitive to the desirable quantity and insensitive to the unwanted quantity.
- If this is not possible, ways and means should be found to eliminate or compensate for the effects of the unwanted input quantity.
- **Operating Principle.** The transducers are many times selected on the basis of operating principle used by them. The operating principles used may be resistive, inductive, capacitive, optoelectronic, piezoelectric etc.
- **Sensitivity.** The transducer must be sensitive enough to produce detectable output.
- **Operating Range.** The transducer should maintain the range requirements and have a good resolution over its entire range.



The rating of the transducer should be sufficient so that it does not breakdown while working in its specified operating range.

- **Accuracy.** High degree of accuracy is assured if the transducer does not require frequent calibration and has a small value for repeatability. It may be emphasized that in most industrial applications, repeatability is of considerably more importance than absolute accuracy.
- **Cross sensitivity.** Cross sensitivity is a further factor to be taken into account when measuring mechanical quantities. There are situations where the actual quantity is being measured is in one plane and the transducer is subjected to variations in another plane. More than one promising transducer design has had to be abandoned because the sensitivity to variations of the measured quantity in a plane perpendicular to the required plane has been such as to give completely erroneous results when the transducer has been used in practice.

#### **Advantages of transducers:**

- Attenuation can be done easily.
- Mass inactivity effects can be reduced.
- Friction effects can be reduced.
- The output can be specified & recorded remotely at a distance from the sensing medium.
- The signal can be mixed to get any permutation with outputs of related transducers otherwise control signals.

Working principle of Strain Gauges, define Strain Gauge.

- A strain gauge is a type of electrical sensor.
- A strain gauge is a sensor whose measured electrical resistance varies with changes in strain.
- Strain is the deformation or displacement of material that results from an applied stress.
- Stress is the force applied to a material, divided by the material's cross-sectional area.

- Strain gauges convert the applied force, pressure, torque, etc. into an electrical signal which can be measured.
- Force causes strain, which is then measured with the strain gauge by way of a change in electrical resistance.
- Then the voltage measurement is done by electrical instruments.

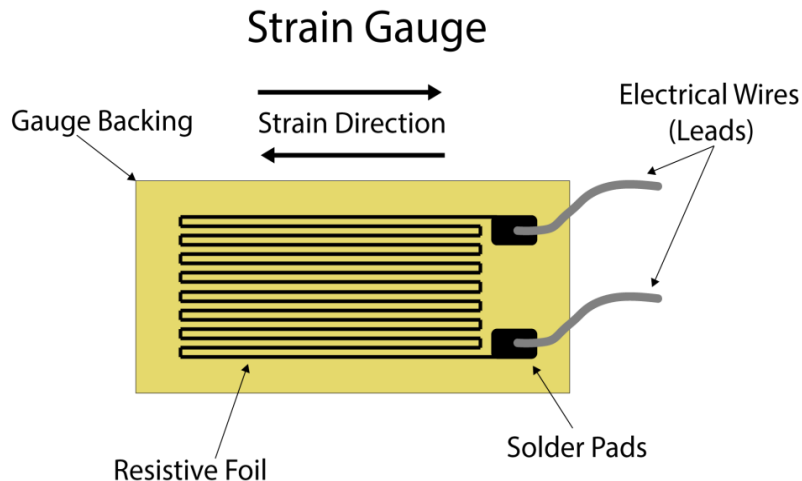

## LINEAR VARIABLE DIFFERENTIAL TRANSFORMER (LVDT)

### Working principle of LVDT

#### Principle:

- The working of LVDT is based on the principle of Faraday's law of electromagnetic induction that states that "the net induced emf in the circuit is directly proportional to the rate of change of magnetic flux across the circuit, and the magnetic flux of the coil wound with wires can be changed by moving a bar magnet through the coil.
- LVDT stands for Linear Variable Differential Transformer.

#### DIAGRAM:

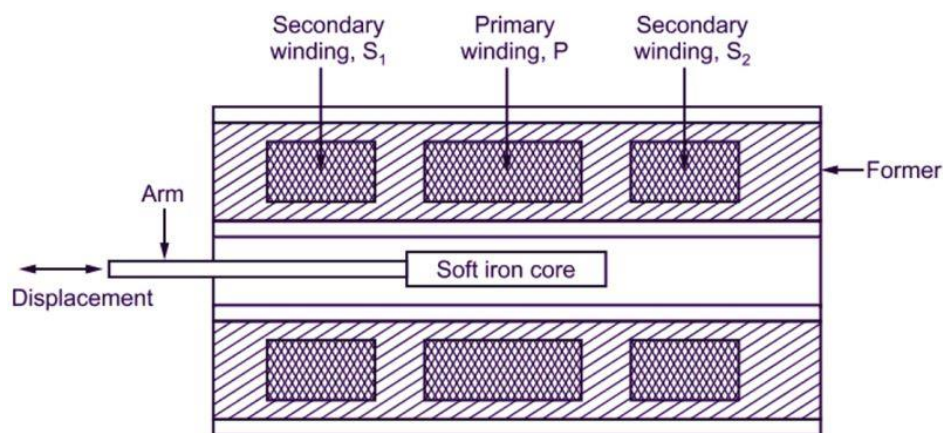
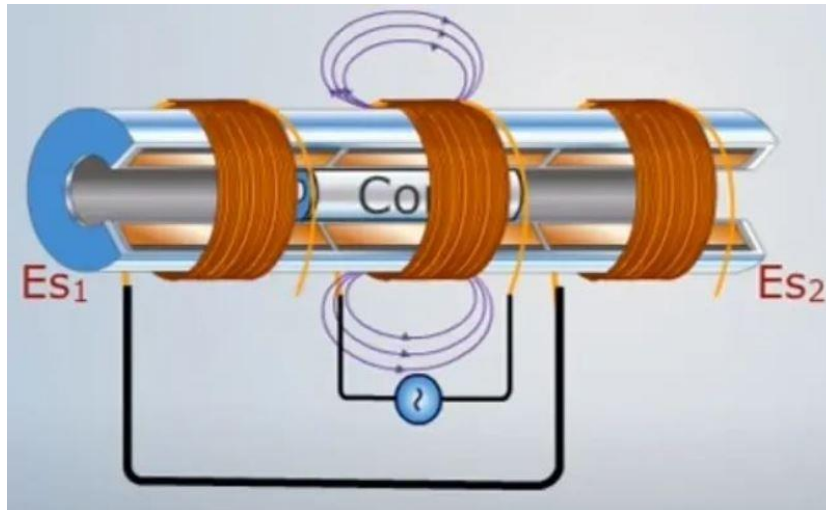

### CONSTRUCTION:

- The structure of LVDT is similar to the transformer.
- It consists of one primary winding, i.e., P and two secondary windings, i.e., S1 and S2.
- The primary and secondary windings are wound on a hollow cylindrical shaped structure, called former.
- The former is usually made of glass-reinforced polymer wrapped in a highly permeable material and then covered with cylindrical steel.
- The primary winding is at the center of the cylindrical former and the secondary windings are present on both sides of the primary winding at an equal distance from the center.
- Both the secondary windings consist of an equal number of turns, and they are linked with each other in series opposition.
- The movable part of LVDT is a separate arm that is made up of a magnetic material.

- It is usually a soft iron core, which is laminated to reduce the losses due to eddy current.
- The core can freely move within the hollow coil (former), and the object whose displacement is to be measured is attached to the core through a non-magnetic rod.

### Working of LVDT:

- When current flows through the primary winding it induces voltage across the secondary coils.
- Let the induced voltage be  $E_1$  and  $E_2$  across the secondary coils  $S_1$  &  $S_2$  respectively.
- Since the secondary windings are connected in series and opposite phases their net induced voltage will be  $E = E_1 - E_2$ .
- The net emf induced in the circuit depends upon the position of the movable core; let us discuss the three different cases according to the position of the core.

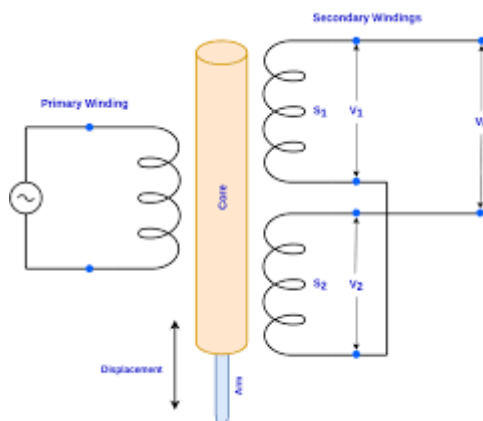

- *CASE 1: Core at the Null Position*
- when the core is placed at the center, the induced emf's  $E_1$  and  $E_2$  in the secondary windings  $S_1$  and  $S_2$  respectively will be the same, i.e.,  $E_1 = E_2$ .
- Hence, the net induced emf ( $E_0$ ) in the circuit at the normal position of the core is zero ( $E_1 - E_2 = 0$ ).
- The normal position of the soft iron core at which the net induced emf is zero is called the 'Null Position' of the LVDT. As shown in the figure.

- *CASE 2: Core at the Left of Null Position*
- If the core is moved towards the left from the null position, the induced emf in coil  $S_1$  will be larger than the induced emf in coil  $S_2$ .
- Hence, the tool output voltage ( $E_{\text{output}}$ ) of LVDT is given by,  $E_{\text{output}} = E_1 - E_2 = \text{Positive}$  ( $E_1 > E_2$ )

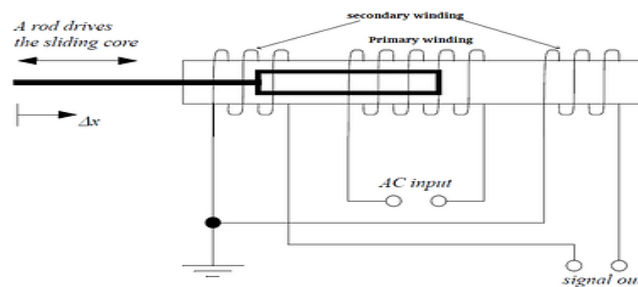

- *CASE 3: Core at the Right of Null Position*
- If the core is displaced from the null position and moved towards the right, the induced emf in winding  $S_2$  will become more than the emf induced in winding  $S_1$ .
- Hence, the tool output voltage ( $E_{\text{output}}$ ) of LVDT is given by,  $E_{\text{output}} = E_1 - E_2 = \text{Negative}$  ( $E_2 > E_1$ ).
- From all the three cases discussed above, it can be concluded that the displacement of the body is directly proportional to the output voltage.
- Hence, the direction of the movement of the body attached to the core of the LVDT can be found out with the help of net output voltage obtained across the output terminal of the LVDT.

## CAPACITIVE TRANSDUCERS (PRESSURE)

## Working principle of capacitive transducers (pressure)

- A linear change in capacitance with changes in the physical position of the moving element is used to provide an electrical indication of the element's position.
- The capacitance is given by

$$C = k \frac{A}{D}$$

where

- K = the dielectric constant
- A = the total area of the capacitor surfaces
- D = distance between two capacitive surfaces
- C = the resultant capacitance.
- From the above equation, it is seen that capacitance increases (i) if the effective area of the plate is increased, and (ii) if the material has a high dielectric constant.
- The capacitance is reduced if the spacing between the plates is increased.
- Transducers which make use of these three methods of varying capacitance have been developed.
- With proper calibration, each type yields a high degree of accuracy in measurement.

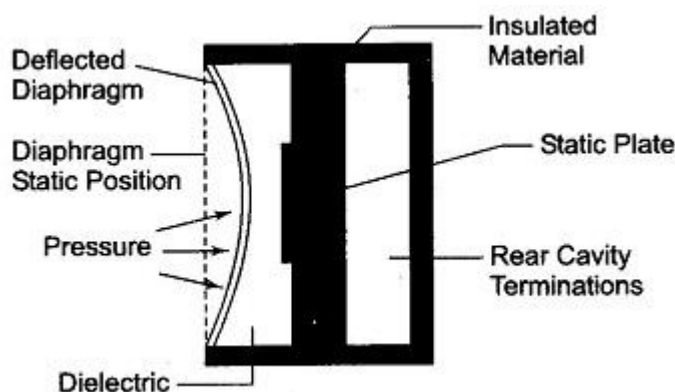

## LOAD CELL (PRESSURE CELL)

- Load cell is a sensor or a transducer that converts a load or force acting on it into an electrical signal.
- This electrical signal can be a voltage change, current change or frequency change depending on the type of load cell and circuitry used.

### Working principle of Load Cell (Pressure Cell)

- **Resistive load cells** work on the principle of piezo-resistivity. When a load/force/stress is applied to the sensor, it changes its resistance. This change in resistance leads to a change in output voltage when an input voltage is applied.
- **Capacitive load cells** work on the principle of change of capacitance which is the ability of a system to hold a certain amount of charge when a voltage is applied to it. For common parallel plate capacitors, the capacitance is directly proportional to the amount of overlap of the plates and the dielectric between the plates and inversely proportional to the gap between the plates.
- A load cell consists of an elastic member as the primary transducer and strain gauges as secondary transducer.
- When combination of the strain gauge and elastic member is used for weighing, it is called as load cell.

### Load cells one various types

- (i) Hydraulic load cells.
- (ii) Pneumatic load cell.
- (iii) Strain-gauge load cell.

### WORKING PRINCIPLE OF TEMPERATURE TRANSDUCER

(RTD, OPTICAL PYROMETER, THERMOCOUPLE, THERMISTOR)

- A Temperature Transducer is a device that converts the thermal quantity into any physical quantity such as mechanical energy, pressure and electrical signals etc.
- Temperature transducers consist of sensing element, metal enclosure, and external output terminal.
- Sensing elements are categorized into two types.

(i) Contact sensor device.

Direct contact with the substances and the heat transfer occurs to the sensing element in the form of conduction. These type of preferable for high temperature measurement, typically 50 to 2500 + deg.

Example: Thermocouple

(ii) Noncontact sensor device.

It does not have direct contact with the substances. There is a metal enclosure is used to protect the sensing element.

Example: Thermister.

### **RTD (Resistance Temperature Detector) :-**

- RTD is also called as Resistance Thermometer.
- RTD works on the principle of change in temperature of a conductor changes the resistance of that conductor.
- The variation of resistance  $R$  with temperature  $T$  ( $^{\circ}\text{k}$ ) can be represented by the following relationship.
- $R=R_0(1+\alpha_1T+\alpha_2T^2+\alpha_3T^3+\dots+)$ .

Where  $R_0$  = Resistance of the conductor at temperature  $T=0^{\circ}\text{K}$ .

$\alpha$  = Temperature coefficient.

- Generally platinum wire is used for RTD.

### **THERMISTORS:-**

- Thermistor is a contraction of a thermal resistors.
- Thermistors are generally composed of mixture of metallic oxides.
- Thermistors works on the principle of change in resistance of conductor with the change in temperature of that conductor.
- Generally most of the thermistors have -ve temperature coefficient.
- They are usually called the ideal temperature transducer.



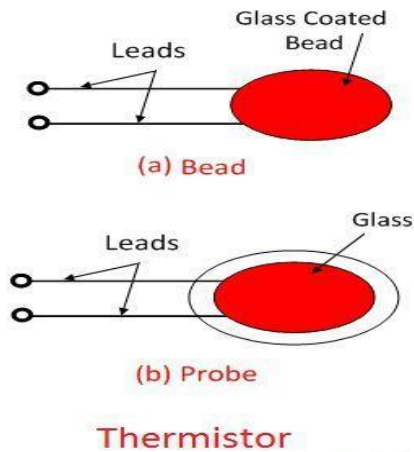

## Properties of Thermistors

- They have Negative Thermal Coefficient i.e. resistance of the thermistor decreases with increase in temperature.
- They are made up of the semiconductor materials.
- They are more sensitive than RTD (Resistance Thermometers) and Thermocouples.
- Their resistance lies between  $0.5\Omega$  to  $0.75\text{ M}\Omega$ .
- They are generally used in applications where measurement range of temperature  $-60^\circ\text{C}$  to  $15^\circ\text{C}$ .

## Thermocouples

- Thermocouple works on the seeback effect, which states that when two metals having different work functions are placed together a voltage difference is generate at Junction which is nearly proportional to the temperature difference between these two junction.
- Thermocouples are temperature transducers that are basically consists of two junctions of dissimilar metals, such as copper and constantan that are welded.
- One junction is kept at a constant temperature called the reference (Cold) junction, while the other the measuring (Hot) junction.
- When the two junctions are at different temperatures, a voltage is developed across the junction which is used to measure the temperature.

## Principle of Thermocouple

- When the junctions of two metals such as copper and constantan are connected together the potential difference is produced is between them.
- The phenomenon is called as the seebeck effect as a temperature gradient is generated along the conducting wires producing an emf.
- Then the output voltage from a thermocouple is a function of the temperature changes.

## Main Features of Thermocouples

- Thermocouples have good sensitivity.
- Extreme temperatures of range between  $-200^{\circ}\text{C}$  to over  $+2000^{\circ}\text{C}$  can be measured with thermocouples which is an advantage over both RTD and Thermistor.
- They are the Active Transducers so they don't require any external source for measuring of temperature as like RTD's and Thermistors.
- They are the cheaper than both RTD's and Thermistors.
- These have small accuracy as compared to RTD's and Thermistors so generally they are not used for high precision work.
- It is suitable for very high frequency measurement.
- Its accuracy is very high.

## OPTICAL PYROMETER

- The noncontact type temperature measurement in which operation of the device happen on the visible radiation from the measurand and is called optical pyrometer.
- Optical pyrometer makes use of the variations in color of a hot body and interprets this phenomena in terms of temperature.
- When a body is heated, it initially becomes dark red turns to orange, and finally becomes white.
- The actual measurement of temperature is based upon the determination of the changes in color of the hot body, and

comparing it with known values produced with a heated filament.

### Working principle of Current transducer

- A current transducer is a device that converts alternating or direct electrical signals into a proportional industrial standard electrical signal.

### Construction

- Current transducer consists of sensitive component.
- It also consists of a conversion component.
- It consists of a conversion circuit.
- It consists of a power circuit.

### Diagram

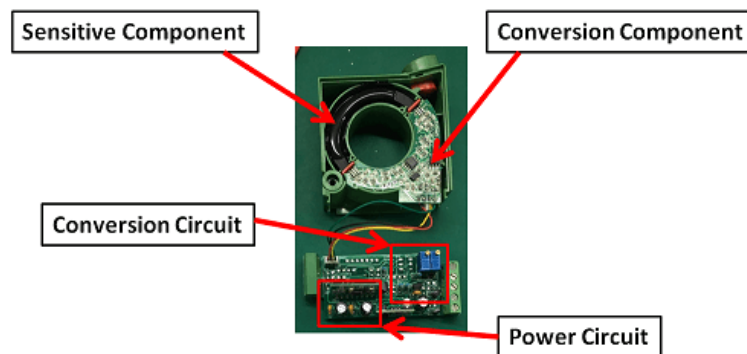

### WORKING

- First of all the sensitive component will detect the incoming electrical signal and give a signal.

- After that the signal will be passed to conversion component, which can convert the signal to a small current signal.
- Then it will be passed to conversion circuit, which process the small current signal and provide an industrial standard electrical signal, usually is 0-5V, 4-20mA, RS485.
- At the end the output signal goes to terminal equipment, such as display, PLC, alarm unit, automation control, etc.
- Current transducer usually has a power circuit, which provide the power to conversion component and conversion circuit.

#### KW Transducer.

- A watt or power transducer measures true electrical power delivered to a load and converts that measurement to a DC voltage or current signal proportional to the power measured.
- To measure power, the watt transducer must monitor both the voltage and current in a circuit.
- Further, it must be able to accurately determine the phase relationship between the voltage and current.
- This is the angle by which the current leads or lags the voltage.
- This measurement is very important to accurately determine true power.
- The watt transducer must also measure the power in each of the branches of the circuit.
- Your house, apartment, or small office is wired in what is often referred to as the Edison System.
- This is a three-wire, single phase system with two power lines in a neutral. The watt transducer must measure the power in each of the power lines or mains.
- This circuit requires a two-element watt transducer.
- A two-element watt transducer has two-watt transducers in the same case.
- The outputs of the two transducers or multipliers are summed so that the output signal of the entire watt transducer represents total power.

## CHAPTER- 7

### SIGNAL GENERATOR, WAVE ANALYZER & DAS

General aspect & classification of Signal generators

**Defination of Signal generator:** A Signal generator is an instrument that provides a controlled output waveform or signal for use in testing or aligning, or in measurements on other circuits or equipments.

#### **Classification of Signal Generator:**

The Signal generator can be classified into the following categories:

1. Audio generators
2. Functions
3. Pulse
4. RF
5. Frequency synthesizer.

**Working principle of AF sine & square wave generator.**

BLOCK DIAGRAM:

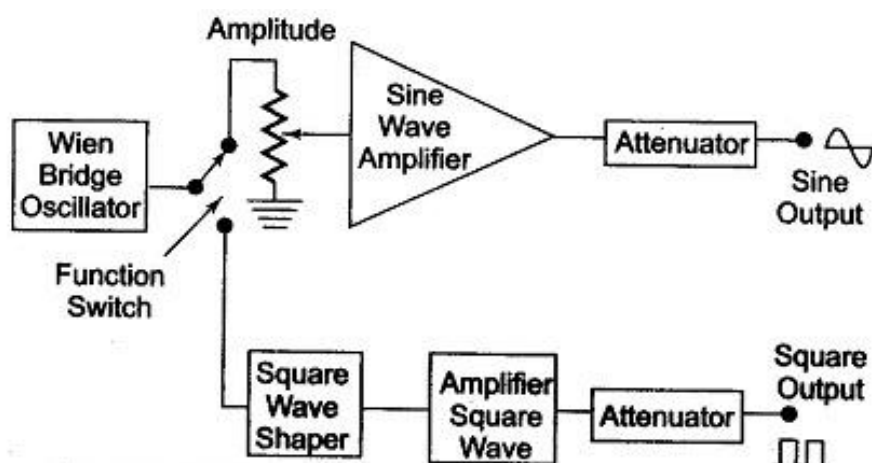

## **Construction**

- It consists a wein bridge oscillator which provide signals of audio frequency range.
- It consists of function switch, amplitude control resistors.
- It consists of sine wave amplifier, square wave amplifier.
- It also consists of attenuator and square wave shaper circuit.

## **Working**

- First of all, function switch is placed as per our requirement of sine wave or square wave amplifier.
- When sine wave section is activated by function switch, the signal from oscillator reaches at sine wave amplifier through amplitude control resistor.
- The sine wave amplifier increases the strength of the signal and gives it to attenuator.
- The attenuator decreases the strength of the spikes present in the amplified signal and its output sine wave output.
- When sequence wave section in activated by function switch the signal form oscillator reaches at sequence wave shaper circuit
- The output of square wave shaper circuit is given to the sequence would amplifier in order to amplify the strength of the signal.
- Then the amplified signal is given is given to the attenuator for cutting of the spikes present in the amplified signal and the final square wave signal is found.
- Then the amplified signal is given to the attenuator the cutting of the spikes presents in the amplified signed and the final sequence wave signal is found.

## Function Generator

### Principle:

- It is defined as the instrument that has the capability of producing different types of wave from as its output signal.
- Function Generator is basically a signal generator that produces different types of waveforms at the output.
- Function Generator is a versatile instrument as an extensive variety of frequencies and waveforms are produced by it.

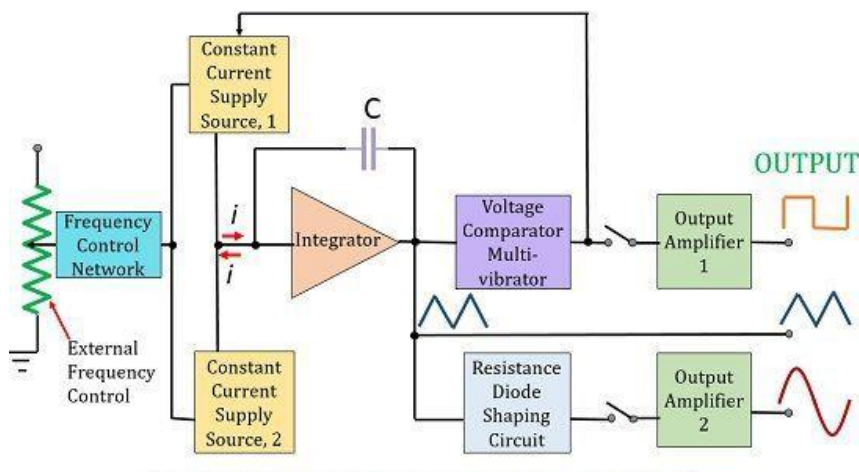

### Construction:

- The function generator consists of an integrator and a frequency control switch.
- It consists of a frequency range selection switch and a submit trigger.
- It consists of a sine wave converter and a function switch.
- It also consists of an attenuator for giving a smooth signal.

### Working:

- First of all the frequency range selection and frequency control switch is adjusted as per the requirement.

- Then the integrator gives its output which is a triangular wave as per the frequency control switch to the sine wave generator and Schmitt trigger.
- If the function switch is connected directly to the integrator than the output of the function generator is a triangular wave from.
- If the function switch is connected to the submit trigger than the output of the generator is a square wave.
- If the function switch is connected to the sine wave converter then the output of the generator is sine wave.
- In this way the function generator works.

### **Basic concept of Data acquisition system (DAS)**

- It is defined as a system used for data processing, data conversion data transmission & data various types
- Data acquisition system one of various types
  - i) Analog data acquisition system.
  - ii) Digital data acquisition system.
- An analog data acquisition system consists of following elements
  - i) Transducers
  - ii) Signal conditioners.
  - iii) Calibrating equipments
  - iv) Integrating equipment
  - v) Visual devices.
  - vi) Graphic recording instrument.
  - vii) Magnetic tape instrumentation.
  - viii) Analog computers.
  - ix) High speed camera & TV equipments.

A digital data acquisition system consists of following elements.

- i) Transfer
- ii) Signal conditioner
- iii) Scanner or multiplexer
- iv) Signal convertor
- v) ADC
- vi) System Programmer
- vii) Digital recorder
- viii) Digital Printer



## Function of basic wave analysis & spectrum Analyse

### Wave analyser

- It is an instrument which measures relative amplitude of single frequency components in a complex waveform.
- Wave analyser are of two types basing upon frequency range.

(i) Basic wave analysis

a) Frequency selective wave analyzer (20-20KHZ)

b) Heterodyne wave analyzer (10KHZ to 18 MHZ)

### Basic wave analyser :-

It is the simplest form of wave analyzer which measures relative amplitudes of single frequency components in a complex or distorted wave from.

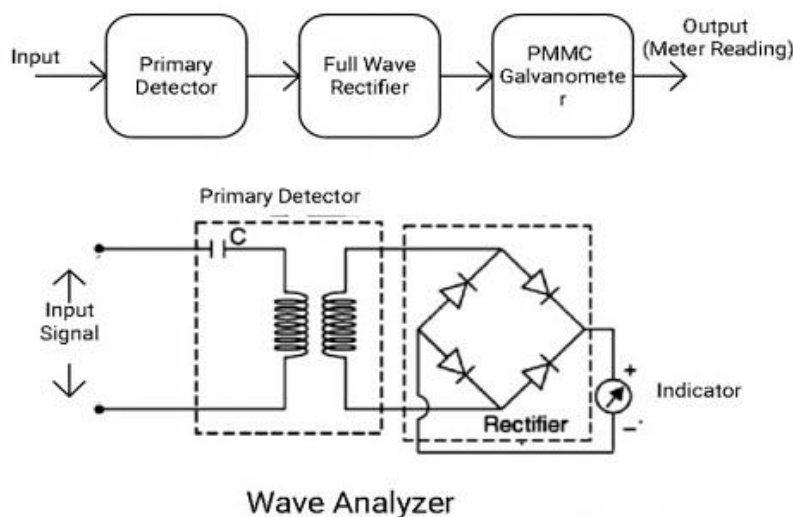

### Construction :-

- It consists of a primary detector.
- It consists of a full wave rectifier.
- It consists of an indicating instrument.

### Working:

- The primary detector the single frequency component and rejects all the frequencies.

- The detected signals average value is provided by the full wave rectifier.
- The indicating device shows the value of single frequency component wave/signal.

### **Wave analyzer based upon frequency range**

Wave analyzer based upon frequency range is of two types

- (i) Frequency selective wave analysis (20HZ-20KHZ).
- (ii) Heterodyne wave analysis (10KHZ-18MHZ).