



KIIT POLYTECHNIC

BHUBANESWAR

CIRCUIT THEORY

3rd Sem Electronics and Telecom. ENGG.

CONTENTS

Chapter 1	Network Elements
Chapter 2	Network Theorem
Chapter 3	AC Fundamentals
Chapter 4	Resonance
Chapter 5	Transient Response of Simple DC Circuit
Chapter 6	Laplace Transform
Chapter 7	Network Function & Parameter
Chapter 8	Filter

CHAPTER -1

NETWORK ELEMENTS

INTRODUCTION:

An electric circuit is an interconnection of electrical elements such as resistors, capacitors, inductors, voltage source etc. In electrical engineering, transfer of energy takes place from one point to another, which requires interconnection of electrical devices. Such interconnection is known as electric circuit and each component of the circuit is known as an element.

EXAMPLE # Consider an electrical circuit as shown in the figure. This electric circuit consists of four elements a battery, a lamp, switch & connecting wires. Circuit and network theorem is the study of the behaviour of the circuit: Its behaviour tells us how does it respond to a given input how do the interconnected elements and devices in the circuit interact?

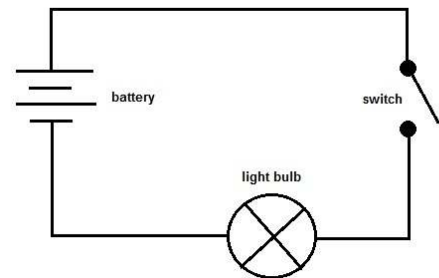

ELECTRIC CURRENT:

Electric current may be defined as the time rate of net motion of an electric charge across a cross sectional boundary as shown in the figure given below. A random motion of electrons in a metal does not constitute a current unless there is a net transfer of charge with time i.e. electric current.

$$\begin{aligned} i &= \text{Rate of transfer of electric charge} \\ &= \text{Quantity of electric charge transferred during a given time} \\ &\quad \text{duration/ Time duration} \\ &= \frac{dQ}{dt} \end{aligned}$$

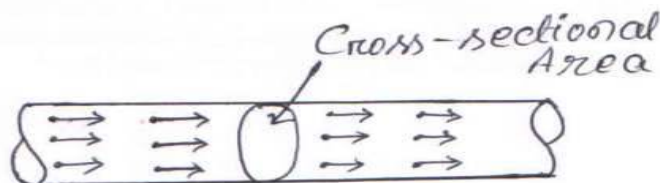

Coulomb is the practical as well as SI unit for measurement of electric charge. Since current is the rate of flow of electric charge through conductor and coulomb is the unit of electric charge, the current may be specified in coulombs per second. In practice the ampere is used as the unit of current. Coulomb is the practical as well as SI unit for measurement of electric charge. Since current is the rate of flow of electric charge through conductor and coulomb is the unit of electric charge, the current may be specified in coulombs per second. In practice the ampere is used as the unit of current.

VOLTAGE:

The voltage is the potential difference between two points of a conductor carrying a current of one ampere when the power dissipated between these two points is equal to one watt. The practical unit of voltage is volt.

POWER:

Power is defined as the rate of doing work or rate at which it can perform work. So Power = work done/ Time in seconds

$$P = \frac{dw}{dt} = \frac{dw}{dq} \frac{dq}{dt} = v i$$

Absolute unit of power is watt. One watt is that power which is required to perform one joule of work in one second. The practical unit of power is horse power (HP). This value in metric system is 75kg meters per second and in British system is 550 Foot Pounds/second. Therefore

$$\begin{aligned} 1 \text{ HP (Metric)} &= 75 \text{ Kg meters per second} = 735.5 \text{ watt} \\ 1 \text{ HP (British)} &= 550 \text{ Foot Pound/ second} = 746 \text{ watt} \end{aligned}$$

ENERGY:

Energy of a body is its capacity of doing work.

$$E = \int_0^t P dt$$

The unit of energy in MKS system is joule and in SI system is KWH. A system can have this energy in various forms, such as electrical, mechanical, heat, chemical, atomic energy etc. Energy of one form can be transformed to other form, but cannot be created nor be destroyed. If one form of energy disappeared, it reappears in another form. This principle is known as law of conservation of energy.

CIRCUIT ELEMENTS/PARAMETERS:

1. RESISTANCE:

Resistance restricts the flow of electric current through the material. Unit of Resistance(R) is Ohm. From Ohm's law

$$R = V/I$$

When an electric current flows through any conductor, heat is generated due to collision of free electrons with atoms. If I amp is the strength of current for potential difference V volts across a conductor, the power observed by resistor is :

$$P = VI = (IR).I = I^2 R \text{ watts}$$

Energy lost in the resistor in form of heat is then

$$E = \int_0^t p. dt = \int_0^t I^2 R dt = I^2 R t = \frac{V^2}{R} \times t$$

2. INDUCTANCE:

It opposes any change of magnitude or direction of electric current passing through the conductor. Unit is Henry (H).When a current will flow through the coils/Inductor an electromagnetic field is created. However in the event of any change

of flow on direction of current, the electromagnetic field also changes. This change of field induces a voltage (V) across the coil & is given by

$$V = L \cdot \frac{di}{dt} \quad \text{----- (1)}$$

Where 'i' is current through the inductor.

Voltage across an inductor is zero when current is constant.

Hence an inductor acts like short circuit to dc.

Power absorbed by inductor

$$P = V \times i = Li \frac{di}{dt} \text{ watts.} \quad \text{----- (2)}$$

Energy absorbed.

$$E = \int_0^t p \cdot dt = \frac{1}{2} Li^2 \quad \text{----- (3)}$$

From equation (2) & (3): The inductor can store finite amount of energy, even the voltage across it may be nil. A pure inductor does not dissipate energy but can only store it.

3. CAPACITANCE:

It is the property of capacitor, which have the capability to store electric charge in its electric field established by the two polarities of charges on the two electrodes of a capacitor.

The amount of charge store by capacitor is

$$q = cv$$

$$i = \frac{dq}{dt} \Rightarrow i = c \frac{dv}{dt}$$

Therefore if voltage across capacitor is constant, current through it is zero. Hence capacitor acts like a open circuit to dc.

$$\text{Power absorbed} \quad P = V \cdot I = VC \frac{dv}{dt}$$

$$\text{Energy stored} \quad E = \int_0^t p \cdot dt = \frac{1}{2} CV^2$$

A capacitor can store finite amount of energy. Even if the current through it is zero. It never dissipates energy.

TYPES OF ELEMENTS:

ACTIVE AND PASSIVE ELEMENT:

An active element has capability to generating energy while passive elements have not.

Ex: Active Element: Generators, Batteries, And Amplifiers.

Passive Element: Resistor, Inductor, capacitor.

BILATERAL AND UNILATERAL ELEMENT:

If the magnitude of current passing through the element is affected due to change in the polarity of the applied voltage, the element is called unilateral element. And if the current magnitude remains same, it is called as bilateral element.

Ex: Unilateral Element: - Diodes, Transistors.

Bilateral Element: - Resistor, Inductor, Capacitor

LINEAR AND NON-LINEAR ELEMENTS:

A linear element shows linear characteristics of voltage Vs current. Resistors, Inductor, Capacitor are linear elements and their property does not change in applied voltage on circuit current.

For non-linear elements the current passing through it does not change linearly with the time as change in applied voltage at a particular frequency.

Ex: Semiconductor devices.

ENERGY SOURCES:

Independent Energy sources: The voltage & current sources whose values or strength of voltage and current does not change by any variation in the connected network are called independent sources.

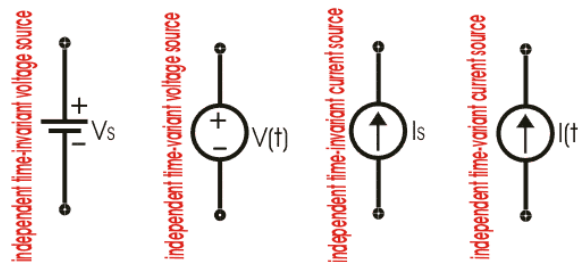

Series connected independent sources: Consider the series connection of two voltage sources as shown in the figure. By KVL the total voltage between the terminals is equal to algebraic sum of individual sources i.e. the voltage sources connected in series may be replaced by a single voltage source whose voltage is equal to the algebraic sum of the individual sources.

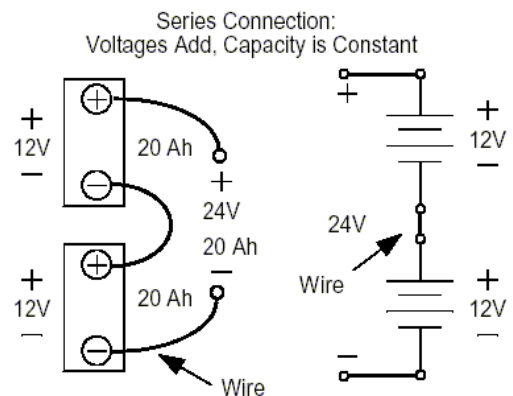

Dependent Energy sources: When the strength of voltage and current changes in the sources for any change in the connected network, they are called dependent sources. There four different types of dependent sources

- a) Voltage controlled voltage source (VCVS)
- b) Voltage controlled current source (VCCS)
- c) Current controlled voltage source (CCVS)
- d) Current controlled current source (CCCS)

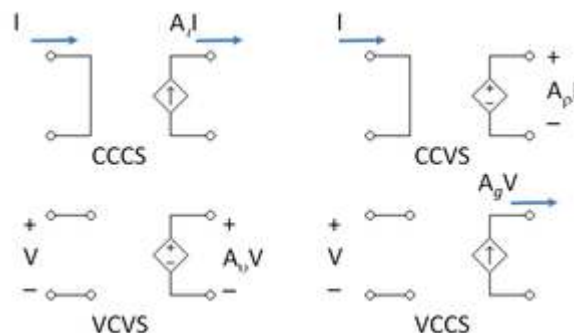

SOURCE TRANSFORMATION:

The voltage and current sources are mutually transferable as shown in the figure below.

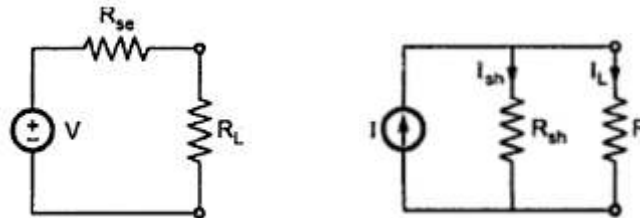

KIRCHHOFF'S LAW:

These laws are more comprehensive than Ohm's law and are used for solving electrical networks which may not be readily solved by latter. Kirchhoff's law is of two types, Kirchhoff's current law and Kirchhoff's voltage law. Kirchhoff's current law is used when voltage is chosen as variable while Kirchhoff' voltage law is used when current is chosen as variable.

KCL: According to Kirchhoff's current law the algebraic sum of currents at any node of a circuit is zero. From the figure given below:

$$-I_1 - I_2 + I_3 - I_4 + I_5 = 0$$

$$\Rightarrow I_1 + I_2 + I_4 = I_3 + I_5$$

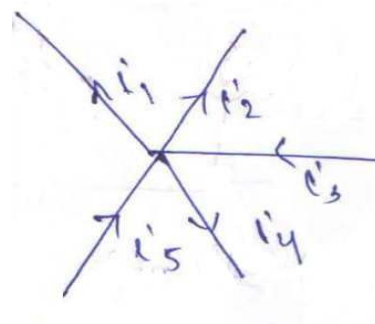

Hence:

Algebraic sum of currents entering a node =
Algebraic sum of current leaving a node.

Example1: Find the magnitude and direction of the unknown current as shown in figure given $I_1 = 10\text{ A}$, $I_2 = 6\text{ A}$, $I_5 = 4\text{ A}$

Solution: Assume direction of current in the network

- (i) $I_1 = I_7 = 10\text{ A}$
- (ii) $I_1 = I_2 + I_4 \Rightarrow I_4 = I_1 - I_2 = 10 - 6 = 4\text{ A}$
- (iii) At node b: $I_2 - I_3 - I_5 = 0$
 $\Rightarrow 6 - I_3 - 4 = 0 \Rightarrow I_3 = 2\text{ A}$
- (iv) At node d: $I_4 + I_3 - I_6 = 0$
 $\Rightarrow 4 + 2 - I_6 = 0$
 $\Rightarrow I_6 = 6\text{ A}$

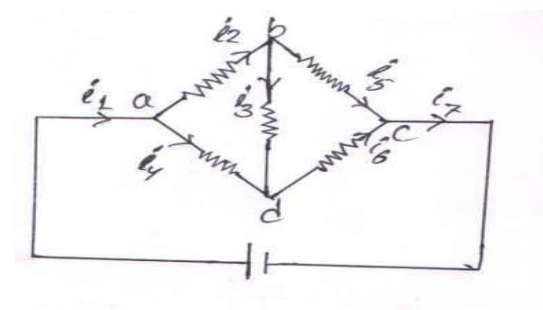

Assume direction of all current are correct because of their positive magnitude. Assume directions of unknown current are arbitrary and any direction can be taken.

Example2: Find v and the magnitude and direction of the unknown currents in the branch xn , yn and zn as shown in figure.

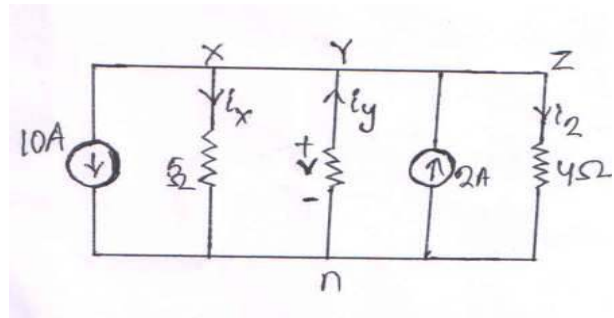

Solution:

$$\text{At node y: } 10 + i_x + i_z = i_y + 2$$

$$i_x - i_y + i_z = -8$$

$$\frac{V}{5} + \frac{V}{2} + \frac{V}{4} = -8 \quad [\text{since } i_x = \frac{V}{5}, i_y = -\frac{V}{2}, i_z = \frac{V}{4}]$$

$$V = -8.42 \text{ volt}$$

Negative magnitude shows that v to be positive.

Therefore $i_x = \frac{-8.42}{5} = -1.684 \text{ A}$ (i.e. from flowing current n to x)

$$i_y = -\frac{(-8.42)}{2} = 4.21 \text{ A}$$
 (ie Current flowing from n to y)

$$i_z = \frac{-8.42}{4} = -2.1 \text{ A}$$
 (ie current flowing from n to z)

The circuit can be redrawn as given below

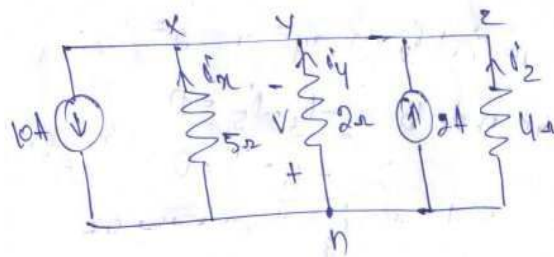

Example3: Find i_1 and i_2 as shown in figure

Solution: The circuit is redrawn in figure

According to KCL: $i_1 + i_2 = 5 + 4 i_2$ ----- (1)

$$i_1 - 3 i_2 = 5$$
 ----- (2)

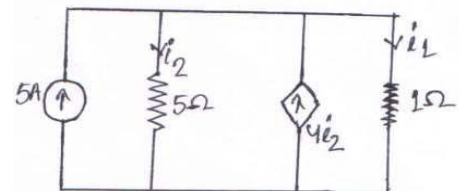

Here $i_1 = \frac{V}{1}$; $i_2 = \frac{V}{5}$

Therefore equation 2: $V - 3\frac{V}{5} = 5$

$$\Rightarrow V = 12.5 \text{ volt}$$

Therefore $i_1 = 12.5 \text{ A}$ and $i_2 = 2.5 \text{ A}$

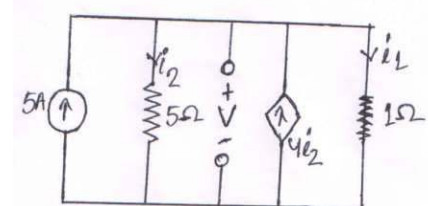

KIRCHHOFFS VOLTAGE LAW:

This law can be stated as

“The algebraic sum of voltage in any closed path of a network that is traversed in single direction is zero.”

Explanation: According to KVL

$$V_1 - IR_1 - V_2 - IR_2 - IR_3 = 0$$

$$IR_1 + IR_2 + IR_3 = V_1 - V_2$$

$$I = \frac{V_1 - V_2}{R_1 + R_2 + R_3}$$

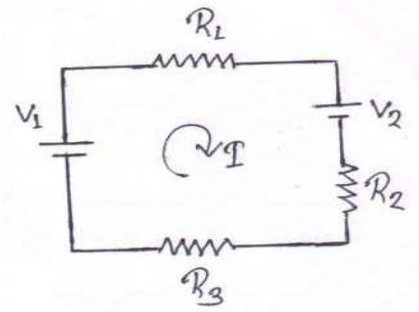

CURRENT DIVISION RULE:

Two resistors are joined in parallel across a voltage V . The current in each branch, as given in ohm's law is

$$I_1 = V/R_1 \text{ and } I_2 = V/R_2$$

Therefore $I_1/I_2 = R_2/R_1 = G_1/G_2$

Hence the division of current in the branch of parallel circuit is directly proportional to the conductance of the branches or inversely proportional to their resistances. We may also express the branch currents in terms of the total circuit current thus:

Now $I_1 + I_2 = I$

$$\Rightarrow I_2 = I - I_1$$

Therefore $\frac{I_1}{I - I_1} = \frac{R_2}{R_1}$ or $I_1 R_1 = R_2(I - I_1)$

Therefore $I_1 = I \frac{R_2}{R_1 + R_2}$ and $I_2 = I \frac{R_1}{R_1 + R_2}$

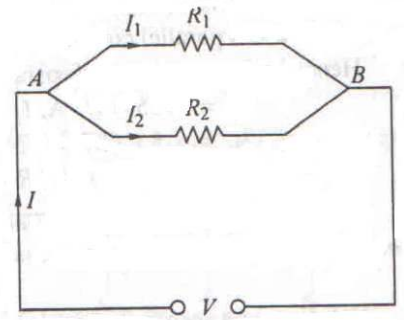

Thus current division rule is stated as

“The current in any of the parallel branches is equal to the ratio of the opposite branch resistance to the total resistance, multiplied by the total current.”

Example4: A resistance of 10 ohm is connected in series with two resistances each of 15 ohm arranged in parallel. What resistance must be shunted across this parallel combination so that the total current taken shall be 1.5 A with 20 volt applied?

Solution: The circuit connected in figure

Drop across 10 ohm resistor = $1.5 * 10 = 15V$

Drop across parallel combination, $V_{AB} = 20 - 15 = 5V$

Hence voltage across each parallel resistance is 5V.

$$I_1 = 5/15 = 1/3 \text{ A}$$

$$I_2 = 5/15 = 1/3 \text{ A}$$

$$I_3 = 1.5 - (1/3 + 1/3) = 5/6 \text{ A}$$

Therefore $I_3 R = 5$ or $(5/6) R = 5$ or $R = 6 \text{ ohm}$

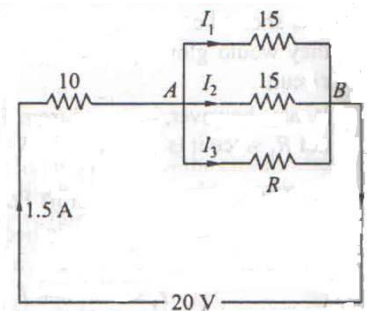

Example5: Calculate the value of different current for the circuit shown in given figure.

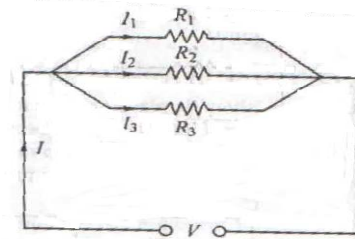

Solution: Total current $I = I_1 + I_2 + I_3$
 Let the equivalent resistance be R .
 Then $V = I R$
 Also $V = I_1 R_1$
 Therefore $I R = I_1 R_1$
 Or $I_1 = I R / R_1$ ----- (1)
 Now $(1/R) = (1/R_1) + (1/R_2) + (1/R_3)$

$$R = \frac{R_1 R_2 R_3}{R_1 R_2 + R_2 R_3 + R_3 R_1}$$

From equation 1: $I_1 = \frac{R_2 R_3}{R_1 R_2 + R_2 R_3 + R_3 R_1}$

Similarly $I_2 = \frac{R_1 R_3}{R_1 R_2 + R_2 R_3 + R_3 R_1}$

$$I_3 = \frac{R_1 R_2}{R_1 R_2 + R_2 R_3 + R_3 R_1}$$

VOLTAGE DIVISION RULE:

A voltage divider circuit is a series network which is used to feed other networks with a number of different voltages and is derived from a single input voltage source. Figure shows a simple voltage divider circuit which provide two output voltages V_1 and V_2 . Since no load is connected across the output terminals, it is called an unloaded voltage divider. We may also express the branch voltages in terms of the total circuit voltage thus:

$$\text{Now } V_1 + V_2 = V$$

$$\Rightarrow V_2 = V - V_1$$

Therefore $\frac{V_1}{V - V_1} = \frac{R_1}{R_2}$ or $V_1 R_2 = R_1 (V - V_1)$

Therefore $V_1 = V \frac{R_1}{R_1 + R_2}$ and $V_2 = V \frac{R_2}{R_1 + R_2}$

Thus Voltage division rule is stated as

“The voltage across a resistor in series circuit is equal to the value of that resistor times the total impressed voltage across the series elements divided by the total resistance of the series elements.”

Example9: Find the value of different voltages that can be obtained from a 12 V battery with the help of voltage divider circuit of figure.

Solution:
 $R = R_1 + R_2 + R_3 = 4 + 3 + 1 = 8 \text{ ohm}$
 Drop across $R_1 = V_{R1} = 12 \times (4/8) = 6 \text{ volt}$
 Drop across $R_2 = V_{R2} = 12 \times (3/8) = 4.5 \text{ volt}$
 Drop across $R_3 = V_{R3} = 12 \times (1/8) = 1.5 \text{ volt}$

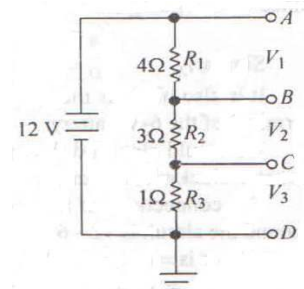

Example10: What are the output voltages of the unloaded voltage divider shown in figure what is the direction of current Through AB?

Solution:

It may be remember that both V1 and V2 are with respect to ground.

$$R = 6 + 4 + 2 = 12 \text{ ohm}$$

Therefore

$$V_1 = \text{Drop across } R_2 = 24 \times (4/12) = 8 \text{ volt}$$

$$V_2 = \text{Drop across } R_3 = -24 \times (2/12) = -4 \text{ volt}$$

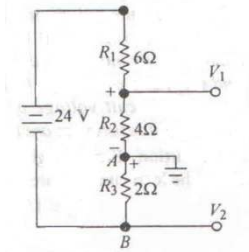

It should be noted that point B is negative potential with respect to the ground. Current flows from A to b i.e. from a point at a higher potential to a point at a lower potential.

Problem 1

Find the values of V , V_{ab} and the power delivered by the 5V source. All values of resistances are in ohm.

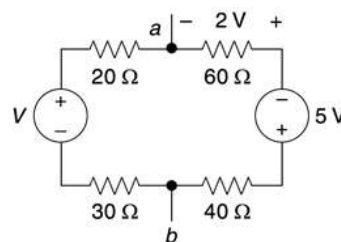

Solution

$$\text{Current, } i = \frac{2}{60} = \frac{1}{30} \text{ A}$$

By KVL,

$$20i + 2 + 5 + v + 70i = 0$$

$$v = -7 - 90i = -7 - 90 \times \frac{1}{30} = -10 \text{ V}$$

$$\therefore v_{ab} = 20i + v + 30i = 50i - 10$$

$$= 50 \times \frac{1}{30} - 10 = -8.33 \text{ V}$$

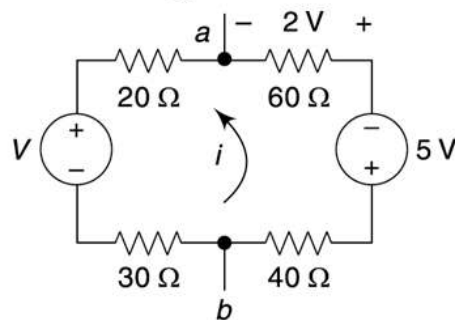

$$\text{Power drawn by the 5V source} = -(\text{Power taken source}) = -5 \times \frac{1}{30} = -0.166 \text{ W}$$

Problem 2

Find the equivalent resistance between the terminals A and B of the circuit shown below.

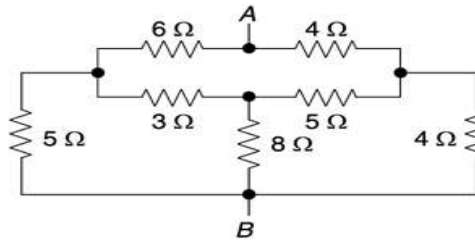

Solution

Converting star into delta,

$$r_{12} = \left(r_1 + r_2 + \frac{r_1 r_2}{r_3} \right) = 8 + \frac{15}{8} = 9.875 \Omega$$

$$r_{23} = \left(r_2 + r_3 + \frac{r_2 r_3}{r_1} \right) = 13 + \frac{40}{3} = 26.33 \Omega$$

$$r_{31} = \left(r_3 + r_1 + \frac{r_3 r_1}{r_2} \right) = 11 + \frac{24}{5} = 15.8 \Omega$$

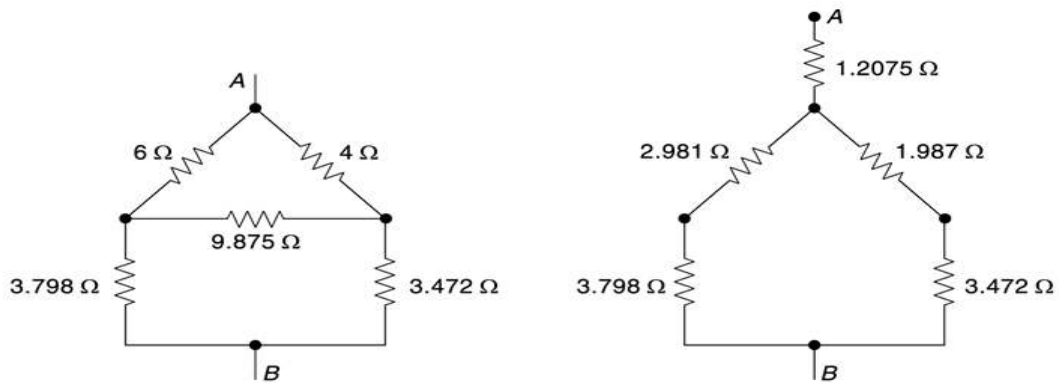
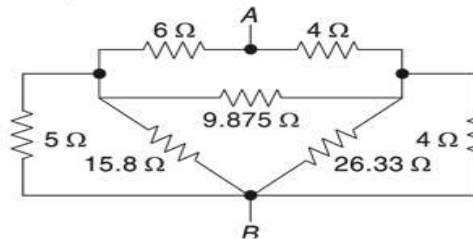

Combining the parallel connections of 5Ω and 15.8Ω and 4Ω and 26.33Ω , we have the reduced circuit.

Again, converting the delta made of 6Ω , 4Ω and 9.875Ω into equivalent star,

$$\begin{aligned} r_1 &= \frac{r_{12} r_{31}}{r_1 + r_2 + r_3} \\ &= \frac{6 \times 4}{19.875} = 1.2075 \Omega \\ r_2 &= \frac{4 \times 9.875}{19.875} = 1.987 \Omega \\ r_3 &= \frac{6 \times 9.875}{19.875} = 2.981 \Omega \end{aligned}$$

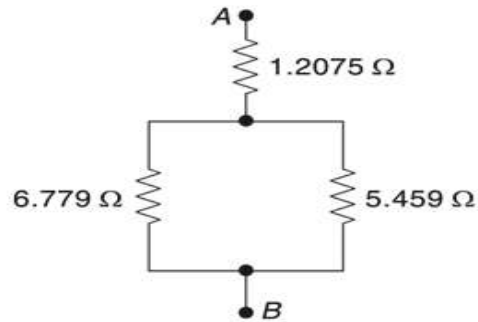

So, the given circuit becomes as shown in figure.

$$\therefore R_{AB} = 1.2075 + \frac{6.779 \times 5.459}{6.779 + 5.459} = 4.23 \Omega \text{ Ans.}$$

Problem 3

Find the current through the galvanometer using delta-star conversion.

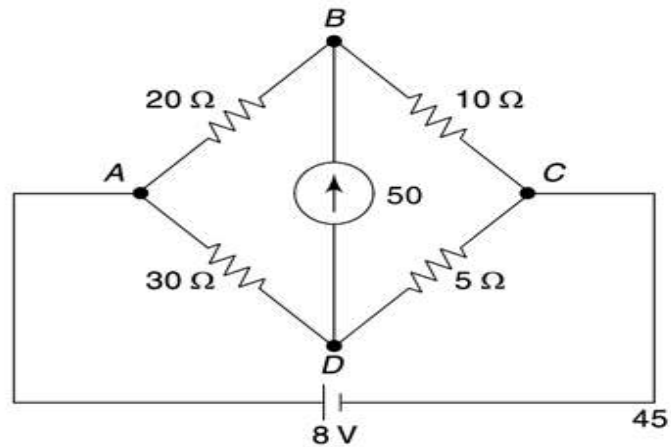

Solution

Converting the delta consisting of 20 Ω, 30 Ω and 50 Ω, we get,

$$r_1 = \frac{20 \times 30}{20 + 30 + 50} = 6 \Omega$$

$$r_2 = \frac{20 \times 50}{20 + 30 + 50} = 10 \Omega$$

$$r_3 = \frac{30 \times 50}{20 + 30 + 50} = 15 \Omega$$

$$\therefore R_{AC} = 16 \Omega$$

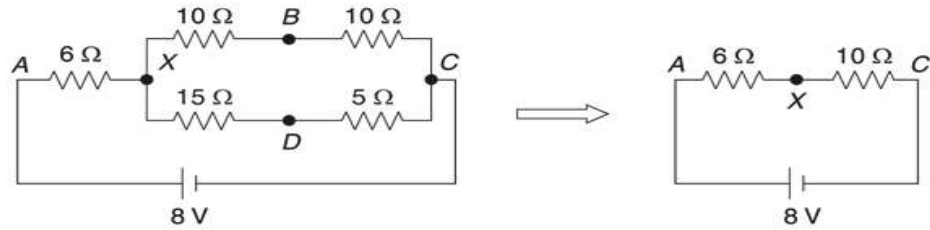
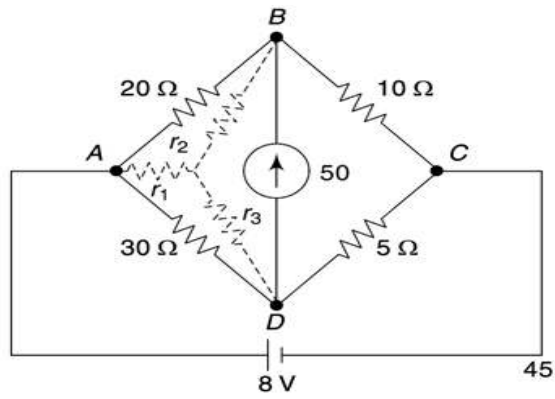

Main current $i = \frac{8}{16} = 0.5 \text{ A}$

Now, to calculate potential difference between the points B and D ;

$$V_{XC} = 10 \times 0.5 = 5 \text{ V}$$

$$\therefore V_{BD} = (10 \times 0.25 - 5 \times 0.25) = 1.25 \text{ V}$$

\therefore Current through the galvanometer, (50Ω)

$$i_G = \frac{1.25}{50} = 0.025 \text{ A}$$



CHAPTER -2

NETWORK THEOREMS

INTRODUCTION

Electric circuits on network consist of a number of interconnected single circuit elements. This circuit will generally contain at least one voltage or current source. The arrangement of elements results in a new set of constraints between currents and voltages. These new constraints and their corresponding equations added to the current-voltage relationships of the individual elements provide the solution of the network. There are different approaches for this but the solution is always unique.

STAR DELTA TRANSFORMATIONS

Figure shows a Y (star or wye) connected resistance circuit. Let the resistor value of Y network are R_a , R_b and R_c . Figure shows a (delta) connected resistances and Let the resistor values are R_{ab} , R_{bc} and R_{ca} .

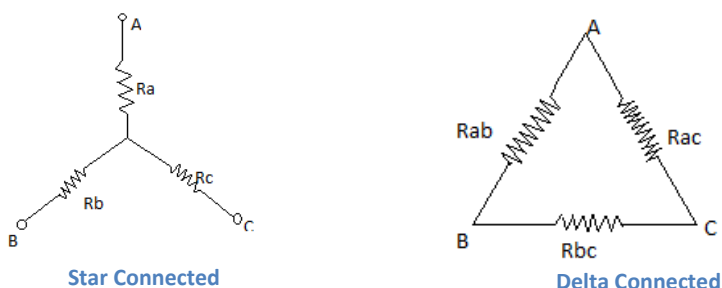

It is possible to substitute a star connected system of resistance for a delta system and vice-versa if proper values are given to the substituted resistances.

DELTA TO STAR CONVERSION

The two systems will be exactly equivalent if the resistance between any pair of terminals A, B and C in figure for the star is the same as that between the corresponding pair for the delta connection when the third terminal is isolated.

For the Y-network resistance between the terminal

A and B is $R_{ab} = R_a + R_b$ -----eq. (i)

For the Δ network resistance between the terminals AB is

$$R_{ab} = R_{ab} \parallel (R_{ac} + R_{bc})$$

$$= \frac{R_{ab} (R_{ac} + R_{bc})}{R_{ab} + R_{ac} + R_{bc}}$$

-----eq. (ii)

Hence $R_a + R_b = \frac{R_{ab} (R_{ac} + R_{bc})}{R_{ab} + R_{ac} + R_{bc}}$ -----eq. (iii)

Similarly for Y-network resistance between terminal B and C is

$$R_{bc} = R_b + R_c$$

For the Δ network resistance between terminal B and C is

$$R_{bc} = R_{bc} \parallel (R_{ab} + R_{ac})$$

$$R_b + R_c = \frac{R_{bc}(R_{ab} + R_{ac})}{R_{bc} + R_{ab} + R_{ac}} \quad \text{eq. (iv)}$$

Similarly we can find R_{ac} between terminal A and C is

$$R_a + R_c = \frac{R_{ac}(R_{ab} + R_{bc})}{R_{ac} + R_{ab} + R_{bc}} \quad \text{eq. (v)}$$

Subtracting eq.(v) from the sum of eq.(iii) and eq.(iv) yields

$$2 R_b = \frac{2 R_{ab} \cdot R_{bc}}{R_{ab} + R_{bc} + R_{ca}}$$

$$R_b = \frac{R_{ab} \cdot R_{bc}}{R_{ab} + R_{bc} + R_{ca}}$$

Subtracting eq.(iv) from the sum of eq.(iii) & eq.(v) yields

$$2 R_a = \frac{2 R_{ab} \cdot R_{ac}}{R_{ab} + R_{bc} + R_{ac}}$$

$$R_a = \frac{R_{ab} \cdot R_{ac}}{R_{ab} + R_{bc} + R_{ac}}$$

Similarly subtracting eq.(iii) from the sum of eq.(iv) and eq.(v) yields

$$2 R_c = \frac{2 \cdot R_{bc} \cdot R_{ca}}{R_{ab} + R_{bc} + R_{ca}}$$

$$R_c = \frac{R_{bc} \cdot R_{ca}}{R_{ab} + R_{bc} + R_{ca}}$$

Therefore, the equivalent impedance of each arm of the star is given by the product of the impedance of the two delta sides that meet at its ends divided by the sum of there delta impedance

STAR TO DELTA CONVERSION

Similarly we can find conversion formula for Y to Δ as

$$R_{ab} = \frac{R_a \cdot R_b + R_b \cdot R_c + R_c \cdot R_a}{R_c}$$

$$R_{bc} = \frac{R_a \cdot R_b + R_b \cdot R_c + R_c \cdot R_a}{R_a}$$

$$R_{ca} = \frac{R_a \cdot R_b + R_b \cdot R_c + R_c \cdot R_a}{R_b}$$

SOURCE TRANSFORMATIONS

In the circuit analysis, a circuit with either voltage source or current sources is preferred. Sometimes a circuit may have both i.e. voltage source & current source. In that case it is convenient to transform voltage source to equivalent current source and current source to equivalent voltage source .

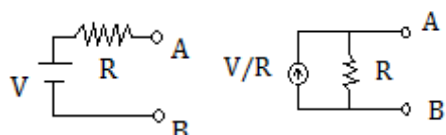

(Transformation of Voltage source to an equivalent current source)

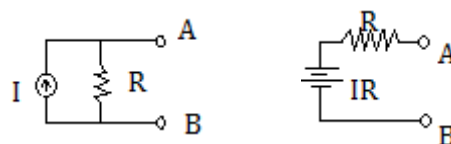

(current source to an equivalent voltage source)

NODE ANALYSIS & MESH ANALYSIS

Two methods one Node analysis and the other mesh analysis are used to analyse a circuit depending on the arrangement and types of elements in the circuit. Nodal analysis is based on Kirchhoff's Current Law (KCL) and Mesh analysis is based on Kirchhoff's Voltage Law (KVL).

NODAL ANALYSIS

Let us consider a circuit shown in fig 2.2 with four nodes. A convenient way of defining voltages for any network is the set of node voltages.

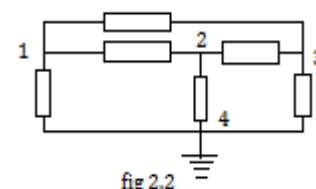

One node i.e. 4 (generally the node at the bottom) is marked as reference node with ground and other nodes are associated with a voltage. The reference node also can be called as Ground Node. In fig 2.2, the voltages V_1, V_2, V_3 are called Node Voltages because they represent the potential differences between the nodes 1, 2 & 3 and reference node respectively. That is the voltage of each of the non-reference nodes with respect to the reference node is defined as a node voltage.

Consider the circuit in figure

$$i_1 = \frac{V_1 - V_2}{R_1} \quad , \quad i_5 = \frac{V_1 - V_3}{R_5}$$

Now applying KCL at node 1, the sum of currents leaving is zero.

Therefore $i_1 + i_5 - i = 0$

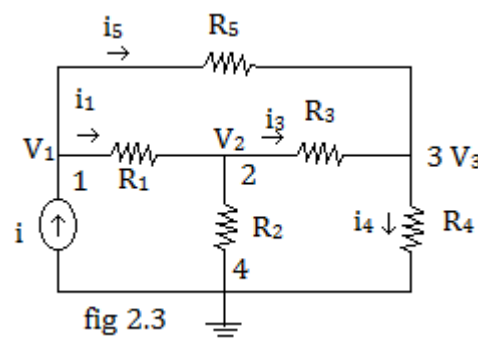

$$i = \frac{V_1 - V_2}{R_1} + \frac{V_1 - V_3}{R_5} \quad \text{eq. (1)}$$

Similarly at node 2 $-i_1 = \frac{V_2 - V_1}{R_1}$, $i_2 = \frac{V_2}{R_2}$, $i_3 = \frac{V_2 - V_3}{R_3}$

$$\frac{V_2 - V_1}{R_1} + \frac{V_2 - V_3}{R_3} + \frac{V_2}{R_2} = 0 \quad \text{eq. (2)}$$

At Node 3 Sum of currents leaving are

$$-i_3 = \frac{V_3 - V_2}{R_3}, \quad i_4 = \frac{V_3}{R_4}, \quad -i_5 = \frac{V_3 - V_1}{R_5}$$

$$\frac{V_3 - V_2}{R_3} + \frac{V_3}{R_4} + \frac{V_3 - V_1}{R_5} \quad \text{eq. (3)}$$

All the above these equation can be solved to determine the individual node voltages V_1, V_2 & V_3 .

Example 1

Find the node voltages V_1 and V_2 for the circuit at figure.

Solution At node 1 apply KCL sum of all the current leaving the node (1) is zero current leaving node 1 are $\frac{V_1}{10}$, $\frac{V_1 - V_2}{15}$ and $-2A$ ($2A$ is entering)

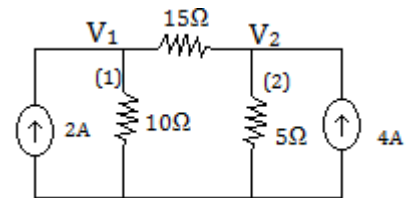

$$\frac{V_1}{10} + \frac{V_1 - V_2}{15} - 2 = 0$$

$$\frac{V_1}{10} + \frac{V_1 - V_2}{15} - 2 = 0$$

$$V_1 \left(\frac{1}{10} + \frac{1}{15} \right) - \frac{V_2}{15} = 2$$

$$5V_1 - 2V_2 = 60 \quad \text{eq. (1)}$$

Similarly At node 2 current leaving are $\frac{V_2}{5}$, $\frac{V_2 - V_1}{15}$ and $-4A$

$$\frac{V_2}{5} + \frac{V_2 - V_1}{15} - 4 = 0$$

$$4V_2 - V_1 = 60 \quad \text{eq. (2)}$$

Solving the above two equations (1) & (2)

We get $V_1 = 20V$, $V_2 = 20V$

Example 2

Find V_1, V_2 and V_3 for the circuit in figure.

Solution

At node 1

$$V_1 - V_2 + \frac{V_1 - V_3}{2} + 3 = 0$$

$$3V_1 - 2V_2 - V_3 = -6 \quad \text{eq. (1)}$$

At node 2

$$V_2 - V_1 + \frac{V_2}{3} + \frac{V_2 - V_3}{4} = 0$$

$$-12V_1 + 19V_2 - 3V_3 = 0 \quad \text{eq. (2)}$$

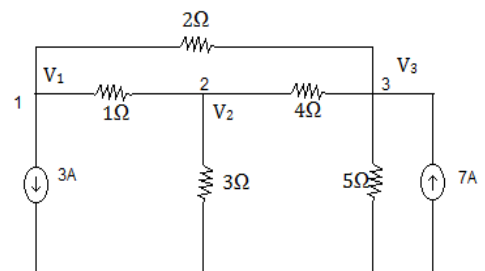

At node 3

$$\frac{V_3 - V_1}{2} + \frac{V_3}{5} + \frac{V_3 - V_2}{4} = 7$$

$$-10V_1 - 5V_2 + 19V_3 = 140 \quad \text{_____ eq. (3)}$$

By solving we get $V_1 = 5.238V$, $V_2 = 5.12V$ & $V_3 = 11.47V$

Example 3

Find the node voltage V_1 & V_2

Solution

To write node equation treat node 1 and 2 and the voltage source together as a Sort of Super node and apply KCL to both nodes at the same time. The super node is individual by dotted line.

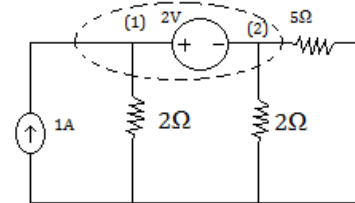

Applying KCL, we get

$$-1 + \frac{V_1}{2} + \frac{V_2}{2} + \frac{V_2}{5} = 0 \quad \text{_____ eq. (1)}$$

And from voltage source $V_1 - 2 = V_2 \quad \text{_____ eq. (2)}$

Now we can solve for V_1 and V_2 using both equations.

MESH ANALYSIS

Mesh analysis is restricted to the category called Planar Circuit whereas nodal analysis can be applied to any electrical circuits. A planar circuit is a circuit if the diagram of the circuit can be drawn on a plane surface without crossover. Example of planar and non-planar circuit are shown in fig (2.7).

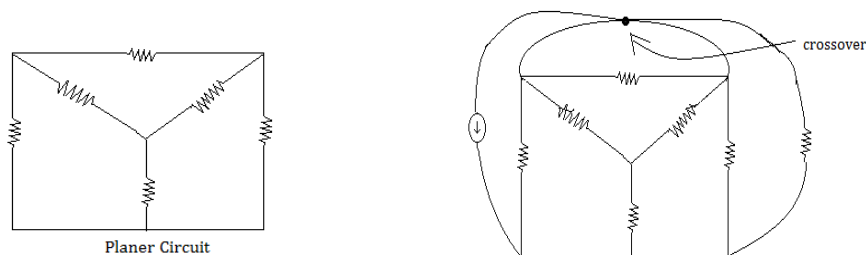
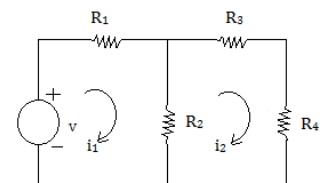

Figure depicts a circuit comprising two meshes.

They are

Mesh 1: $V_5 \rightarrow R_1 \rightarrow R_2 \rightarrow V_3$

Mesh 2: $R_3 \rightarrow R_4 \rightarrow R_2 \rightarrow R_3$



The two mesh currents are labeled as i_1 and i_2 flowing in clockwise direction. Now we will apply KVL around each mesh.

For mesh 1

$$i_1 R_1 + (i_1 - i_2) R_2 = V_5 \quad \text{_____ eq. 1}$$

For mesh 2

$$i_2 R_3 + i_2 R_4 + R_2 (i_2 - i_1) = 0 \quad \text{_____ eq. 2}$$

Eq.(1) & (2) can be rewritten as

$$(R_1 + R_2) i_1 - R_2 i_2 = V_5 \quad \text{_____ eq.3}$$

$$-R_2 i_1 + (R_2 + R_3 + R_4) i_2 = 0$$

Finally the two equations can be put in matrix form

$$\begin{bmatrix} R_1 + R_2 & -R_2 \\ -R_2 & R_2 + R_3 + R_4 \end{bmatrix} \begin{bmatrix} i_1 \\ i_2 \end{bmatrix} = \begin{bmatrix} V_5 \\ 0 \end{bmatrix}$$

Which can be solved for i_1 and i_2 .

Examples 4 find the mesh current i_1 and i_2 for the circuit shown in figure.

For first mesh $2i_1 + 3(i_1 - i_2) = 9$ _____ eq.1

$$4i_2 - 5 + 3(i_2 - i_1) = 0 \quad \text{_____ eq.2}$$

Equation can be rewritten as

$$5i_1 - 3i_2 = 9 \quad \text{_____ eq.3}$$

$$-3i_1 + 7i_2 = 5 \quad \text{_____ eq.4}$$

By solving $i_1 = 3A, i_2 = 2A$

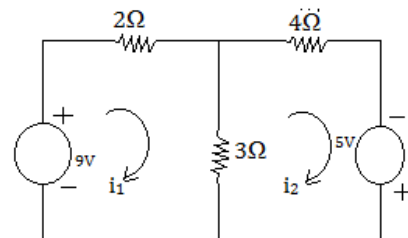

Example 5

Determine the voltage drop across 3Ω resistor using mesh analysis in figure.

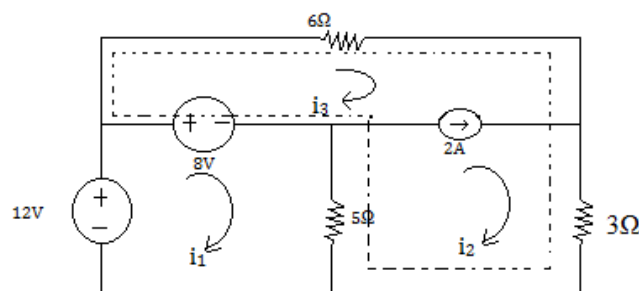

SUPERMESH

When a current source is common to two meshes we use the concept of super mesh to analysis the circuit using mesh current method. A super mesh is a larger mesh created from two meshes that have a current source as common element. A super mesh encloses more than one mesh for each common current source between two meshes, the number of meshes reduce by one, thus reading the number of mesh

Solution to Example 6

The 2A current source is common to mesh 2 & 3. So we create a super mesh as shown in dotted line.

For super mesh

$$\begin{aligned} 6i_3 + 3i_2 + 5(i_2-i_1) - 8 &= 0 \\ \Rightarrow -5i_1 + 8i_2 + 6i_3 &= 8 \end{aligned} \quad \text{_____eq. 1}$$

For mesh 1

$$\begin{aligned} -12 + 8 + 5(i_1 - i_2) &= 0 \\ \Rightarrow 5i_1 - 5i_2 &= 4 \end{aligned} \quad \text{_____eq.2}$$

From current source $i_2 - i_3 = 2$
 By solving we get $i_2 = 2.664$
 Voltage across 3Ω resistor $= 2.66 \times 3 = 8\text{v}$.

Example 7

Use node analysis to find V_1, V_2, V_3 & i_1

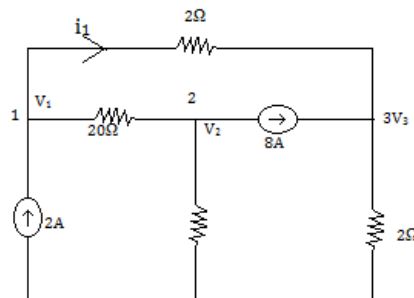

Solution

Applying KCL at node 1

We get

$$\frac{V_1 - V_2}{20} + \frac{V_1 - V_3}{2} = 2 \quad \text{_____eq. 1}$$

Applying KCL at node 2

$$\frac{V_2 - V_1}{20} + \frac{V_2}{4} + 8 = 0 \quad \text{_____eq.2}$$

Applying KCL at node 3

$$\frac{V_3}{2} + \frac{V_3 - V_1}{2} = 8 \quad \text{_____eq.3}$$

By solving all these equations we can get $V_1 = 16\text{v}, V_2 = -24\text{v}, V_3 = 16\text{v}, i_1 = 0\text{A}$

Examples 8

Find the voltage V_2 using mesh analysis.

Solution

Applying KVL for super mesh

$$\begin{aligned} 30i_1 + 20(0.5 + i_1) + 10 &= 0 \\ \Rightarrow 50i_1 &= -20 \\ \Rightarrow i_1 &= -\frac{2}{5} = -0.4\text{A}, V_2 = 20(i_1 + 0.5) \\ &= 20 \times 0.1 = 2\text{v} \end{aligned}$$

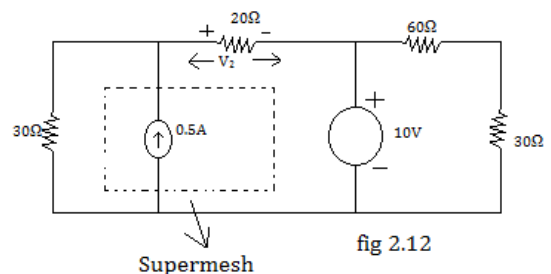

Superposition Theorem

In a linear bilateral network containing two or more independent sources, the voltage across or current in any branch is algebraic sum of individual voltages or currents produced by each independent sources acting separately with all the independent sources set equal to zero.

Procedure to solve the circuit using superposition theorem

1. Select only one source and replace all other sources with their internal resistance. If the source is an ideal current source replace it by open circuit. If the source is an ideal voltage source, replace it by short circuit.
2. Find the current and its direction through the desired branch.
3. Add all the branch currents to obtain the actual branch current.

Examples 9

Find the current through 2Ω register using superposition theorem.

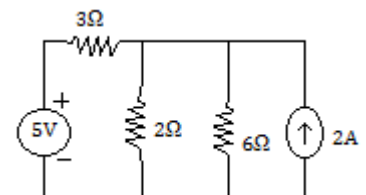

Solution

First we find the contribution to I due to 5V source by replacing 2A current source with open-circuit. Applying KCL for the circuit in figure.

$$\frac{V-5}{3} + \frac{V}{2} + \frac{V}{6} = 0$$

$$V = \frac{5}{3} \text{ v}, I_1 = \frac{5}{6} \text{ Amp}$$

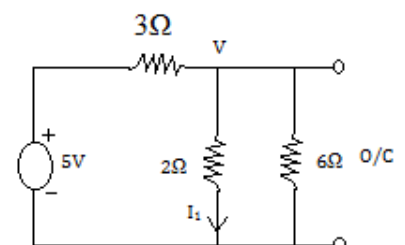

Next we find the contributions I_2 due to 2A current source by replacing the voltage source by short-circuit.

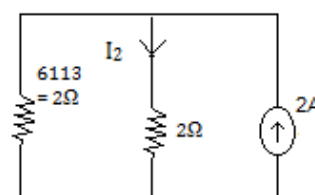
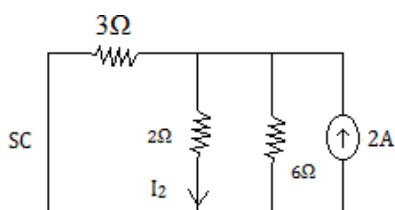

$$I_2 = 2 \times \frac{2}{4} = 1 \text{ Amp}$$

$$\text{Total current flowing through the } 2\Omega \text{ resistor} = I_1 + I_2 = 1 + \frac{5}{6} = \frac{11}{6} \text{ Amp}$$

Limitation of Super-position Theorem

1. Not applicable to the circuits consisting of only dependent sources.
2. Not applicable to the circuits consisting of non-linear elements.
3. Not applicable for calculation of power, since power is potential is proportional to the sequence of current or voltage.
4. Not useful to the circuits consisting of less than two independent sources.

Example 10

Find current I using Superposition theorem for the circuit in the figure.

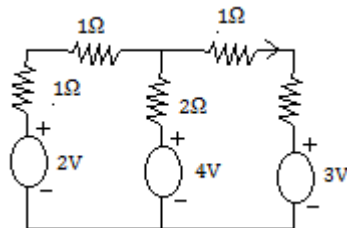

Solution:

The circuit has three voltage sources. First we find the contribution to I_1 due to 2V. Therefore short-circuit the remaining two voltage sources as shown in figure.

$$I^1 = \frac{2}{2 + \frac{6}{5}} = \frac{10}{16} = \frac{5}{8} \text{ A}$$

$$I_1 = \frac{5}{8} \times \frac{2}{5} = \frac{1}{4} \text{ A}$$

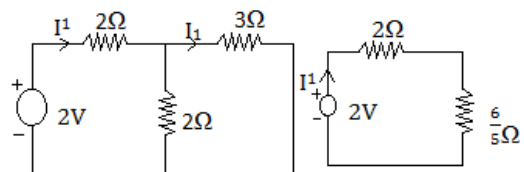

When 4V acting as shown in figure

$$I^1 = \frac{4}{2 + \frac{6}{5}} = \frac{5}{4} \text{ A}$$

$$I_2 = \frac{5}{4} \times \frac{2}{5} = \frac{1}{2} \text{ A}$$

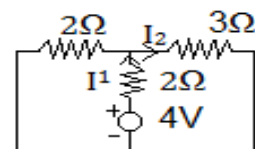

When 3V is acting alone as shown in figure

$$I_3 = -\frac{3}{4} \text{ Amp}$$

When all the sources are acting together total current will be

$$I = I_1 + I_2 + I_3 = \frac{1}{4} + \frac{1}{2} - \frac{3}{4} = \frac{1+2-3}{4} = 0 \text{ Amp}$$

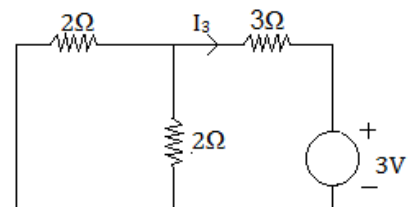

Example 11

Find current I_a

Solution: Let us assume that only 12V is acting done and current through it i_{a1} , open circuit 4A and 1A current source and short-circuit the 6V voltage source as in the figure.

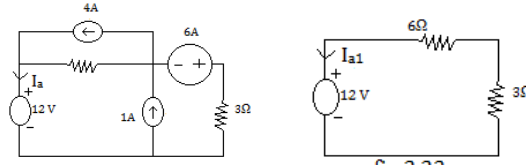

$$I_{a1} = -\frac{12}{9} = -\frac{4}{3} \text{ A}$$

When 4A current source is acting alone as shown in figure.

$$I_{a2} = \frac{4 \times 6}{9} = \frac{24}{9} = \frac{8}{3} \text{ A}$$

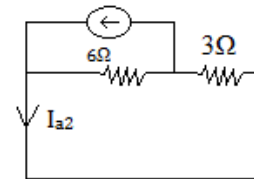

When 1A is acting alone as shown in figure.

$$I_{a3} = 1 \times \frac{3}{9} = \frac{1}{3} \text{ A}$$

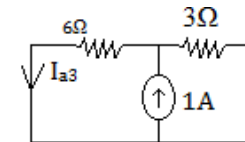

When 6V is acting alone as in figure

$$I_{a4} = \frac{6}{9} = -\frac{2}{3} \text{ A}$$

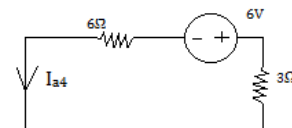

When all the sources are acting total current will be

$$\begin{aligned} I_a &= I_{a1} + I_{a2} + I_{a3} + I_{a4} \\ &= -\frac{4}{3} + \frac{8}{3} + \frac{1}{3} - \frac{2}{3} = \frac{-4+8+1-2}{3} \\ &= \frac{3}{3} \\ &= 1 \text{ amp} \\ I_a &= 1 \text{ A} \end{aligned}$$

APPLICATION OF SUPER-POSITION THEOREM

The super-position theorem is applicable for any linear circuit having time varying or time invariant elements. It is useful in circuit analysis for finding current & voltage when the circuit has a large number of independent sources.

LIMITATION OF SUPER-POSITION THEOREM

1. Not applicable to the circuits consisting of dependent sources.
2. Not applicable to the circuits consisting of non linear elements like diode, transistor etc.
3. Not applicable for calculation of power.

THEVENIN'S THEOREM

Thevenin's theorem states that any linear active two terminal network containing resistance and voltage sources or current sources can be replaced by a single voltage source V_{th} in series with single resistance R_{th} . The Thevenin equivalent voltage V_{th} is the open circuit voltage at the network terminal and the Thevenin resistance R_{th} is the resistance between the network terminals when all the sources are replaced with their internal resistance.

Fig (a) shows a linear network containing resistance, voltage sources or current sources with output terminal AB using Thevenin's theorem the linear network can be replaced by single voltage source V_{th} in series with a single resistor R_{th} as shown in fig(b). Now any resistor can be connected between the terminal AB and current through it can be obtained easily.

Procedure to find the current through a branch using Thevenin's Theorem.

1. Remove the branch through which current is to be found and mark the terminal AB.
2. Calculate the open circuit voltage V_{th} between the terminal AB.
3. Replace the independent sources with their internal resistance. (if the internal resistances are zero, then voltage source should be short-circuited and current source should be open-circuited)
4. Calculate R_{th} between the terminal AB.
5. Connect thevenin's voltage sources in series with Thevenin resistance with output terminal AB.
6. Connect the removed resistance between AB and find the current through it.

Example

Find V_{TH} , R_{TH} and the load current flowing through and load voltage across the load resistor in figure by using Thevenin's Theorem.

Solution

Step 1

Open the $5k\Omega$ load resistor figure.

Step 2

Calculate / measure the Open Circuit Voltage. This is the Thevenin Voltage (V_{TH}) figure. We have already removed the load resistor from figure 1, so the circuit became an open circuit as shown in fig 2. Now we have to calculate the Thevenin's Voltage. Since

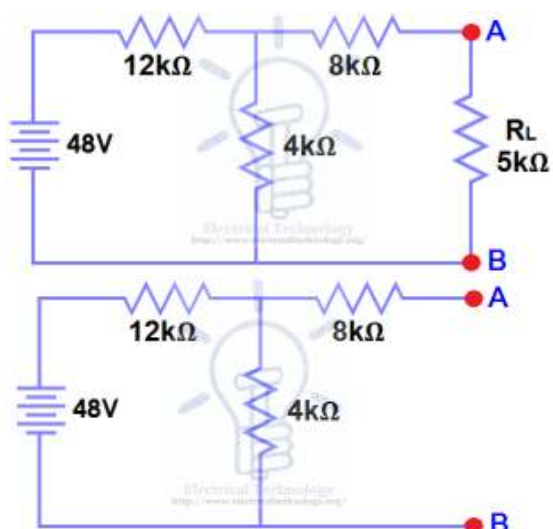

3mA Current flows in both 12kΩ and 4kΩ resistors as this is a series circuit because current will not flow in the 8kΩ resistor as it is open.

So 12V (3mA x 4kΩ) will appear across the 4kΩ resistor. We also know that current is not flowing through the 8kΩ resistor as it is open circuit, but the 8kΩ resistor is in parallel with 4k resistor. So the same voltage (i.e. 12V) will appear across the 8kΩ resistor as 4kΩ resistor. Therefore 12V will appear across the AB terminals. So,

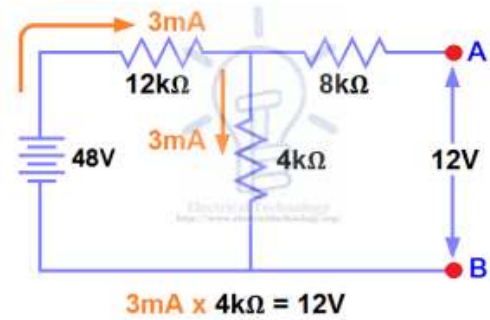

$$V_{TH} = 12V$$

Step 3

Open Current Sources and Short Voltage Sources figure.

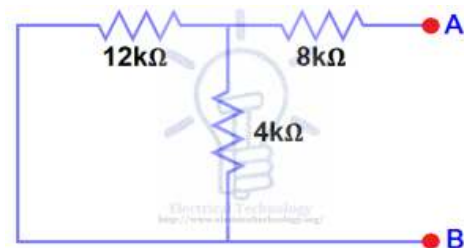

Step 4

Calculate /measure the Open Circuit Resistance. This is the Thevenin Resistance (R_{TH})

We have Reduced the 48V DC source to zero is equivalent to replace it with a short in step (3), as shown in figure () We can see that 8kΩ resistor is in series with a parallel connection of 4kΩ resistor and 12k Ω resistor. i.e.:

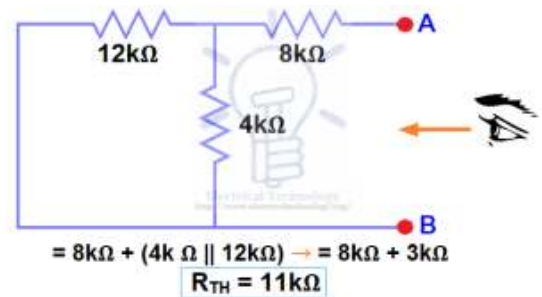

$$8k\Omega + (4k\Omega \parallel 12k\Omega) \dots (|| = \text{in parallel with})$$

$$R_{TH} = 8k\Omega + [(4k\Omega \times 12k\Omega) / (4k\Omega + 12k\Omega)]$$

$$R_{TH} = 8k\Omega + 3k\Omega$$

$$R_{TH} = 11k\Omega$$

Step 5

Connect the R_{TH} in series with Voltage Source V_{TH} and re-connect the load resistor. This is shown in figure i.e. Thevenin circuit with load resistor.

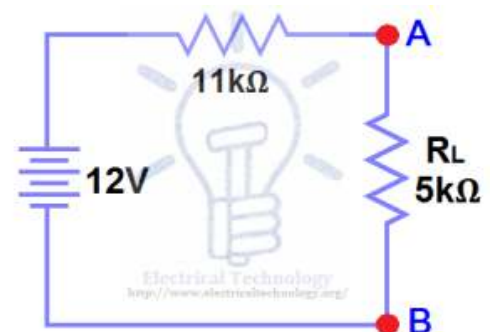

Step 6

Now apply the last step i.e. calculate the total load current & load voltage as shown in figure.

$$\begin{aligned} I_L &= V_{TH} / (R_{TH} + R_L) \\ &= 12V / (11k\Omega + 5k\Omega) \rightarrow \\ &= 12/16k\Omega \end{aligned}$$

$$I_L = 0.75\text{mA}$$

And

$$V_L = I_L \times R_L$$

$$V_L = 0.75\text{mA} \times 5k\Omega$$

$$V_L = 3.75\text{V}$$

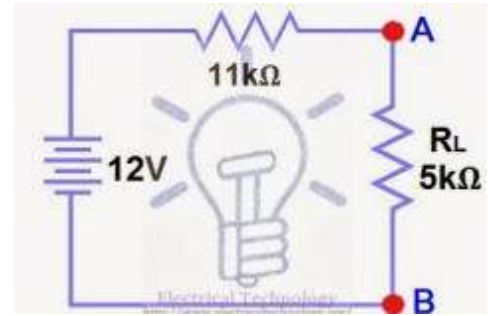

NORTON'S THEOREM

Norton's theorem states that any linear active two terminal network contains resistance and voltage source or current source can be replaced by single current source or current source can be replaced by single current source I_N in parallel with a single resistance R_N . The Norton's equivalent current I_N is the state circuit current through the terminals AB and resistance R_N is the resistance between the network terminals when all the sources are replaced with internal resistances.

Procedure to find the current through a branch using Norton's theorem.

1. Remove the branch through which current is to be found and mark terminal AB.
2. Short-circuit the terminal AB and find current through it and denote it as I_{SC} .
3. Replace the independent sources with their internal resistances (if internal resistances are zero then voltage source should be short circuited and current sources should be open-circuited).
4. Calculate R_N between the terminals AB.
5. Connect the short-circuit current (Norton's) I_n in parallel with R_N with output terminal AB.

Correct the removed branch between terminals AB and find current.

Example

Find the current in RL using Norton's Theorem

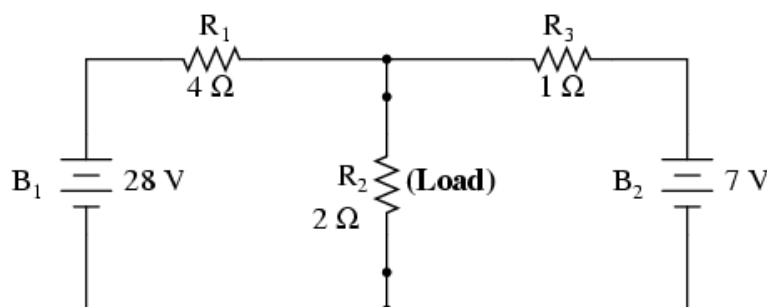

After Norton conversion ...

Remember that a *current source* is a component whose job is to provide a constant amount of current, outputting as much or as little voltage necessary to maintain that constant current.

Norton Equivalent Circuit

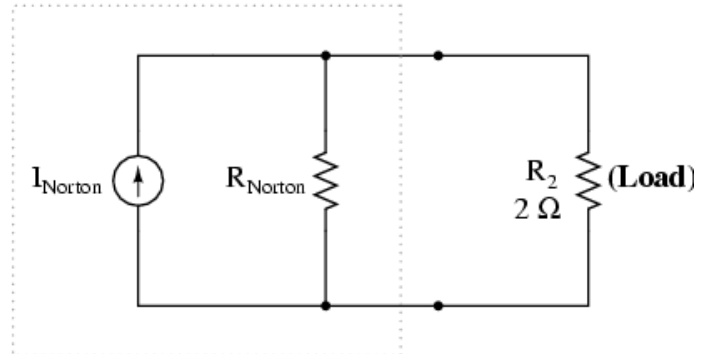

As with Thevenin's Theorem, everything in the original circuit except the load resistance has been reduced to an equivalent circuit that is simpler to analyze. Also similar to Thevenin's Theorem are the steps used in Norton's Theorem to calculate the Norton source current (I_{Norton}) and Norton resistance (R_{Norton}).

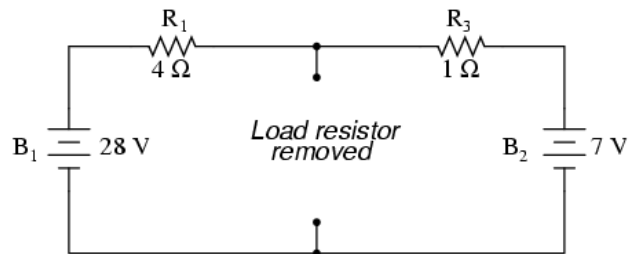

As before, the first step is to identify the load resistance and remove it from the original circuit.

Then, to find the Norton current (for the current source in the Norton equivalent circuit), place a direct wire (short) connection between the load points and determine the resultant current. Note that this step is exactly opposite the respective step in Thevenin's Theorem, where we replaced the load resistor with a break (open circuit).

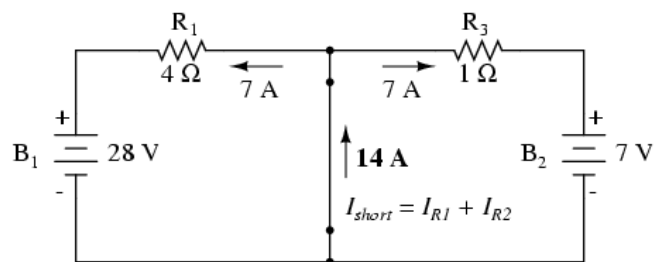

With zero voltage dropped between the load resistor connection points, the current through R_1 is strictly a function of B_1 's voltage and R_1 's resistance: 7 amps ($I=E/R$). Likewise, the current through R_3 is now strictly a function of B_2 's voltage and R_3 's resistance: 7 amps ($I=E/R$).

Norton Equivalent Circuit

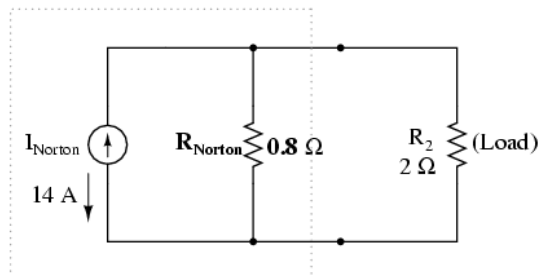

The total current through the short between the load connection points is the sum of these two currents: 7 amps + 7 amps = 14 amps. This figure of 14 amps becomes the Norton source current (I_{Norton}) in our equivalent circuit.

$$\text{Current through load of } 2\Omega \text{ resistor} = 14 \times .8 / 2.8 = 4 \text{ Amp.}$$

Maximum Power Transfer Theorem

In a linear bilateral network containing an independent voltage source in series with resistance R_S delivers maximum power to the load resistance R_L when $R_L=R_S$

Let us consider a circuit shown in fig(a)

$$\text{Current } I = \frac{V_S}{R_S + R_L}$$

$$\text{Power delivered to the load } P_L = I^2 R_L = \left(\frac{V_S}{R_S + R_L} \right)^2 R_L$$

To find the value of R_L for optimum power transfer differentiate P_L with respect to R_L and equal to 2nd

$$\frac{dP_L}{dR_L} = V_S^2 \left[\frac{(R_S + R_L)^2 - 2R_L(R_S + R_L)}{(R_S + R_L)^2} \right] = 0$$

$$\Rightarrow (R_S + R_L)^2 = 2 R_L (R_S + R_L)$$

$$\Rightarrow R_S + R_L = 2 R_L$$

$$\Rightarrow \boxed{R_S = R_L}$$

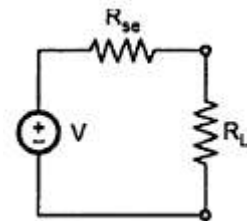

$$\text{Maximum power will be } = (V_S/2R_L)^2 \times R_L = V_S^2/4R_L$$

Example

Find the value of R_L for the given network below that the power is maximum? And also find the Max Power through load-resistance R_L by using maximum power transfer theorem?

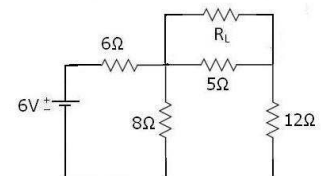

Solution

For the above network, we are going to find-out the value of unknown resistance called " R_L ". In previous post, I already show that when power is maximum through load-resistance is equals to the equivalent resistance between two ends of load-resistance after removing.

So, for finding load-resistance R_L . We have to find-out the equivalent resistance like that for this circuit.

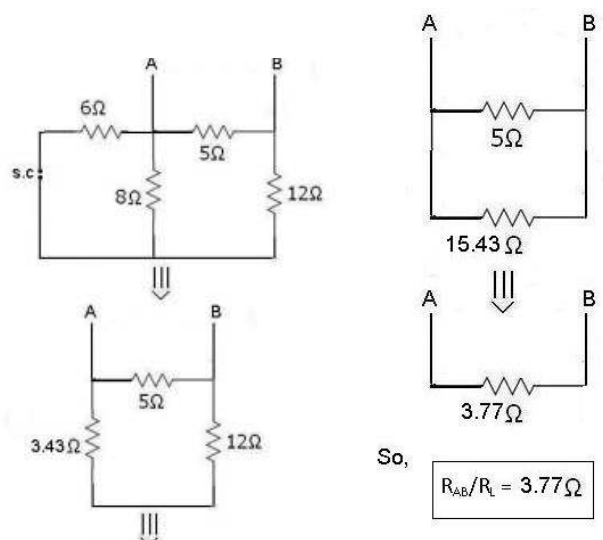

Now, For finding Maximum Power through load-resistance we have to find-out the value of $V_{o.c}$. Here, $V_{o.c}$ is known as voltage between open circuits. So, steps are

For this circuit using Mesh-analysis. We get

Applying Kvl in loop 1st:-

$$6 - 6I_1 - 8I_1 + 8I_2 = 0$$

$$-14I_1 + 8I_2 = -6 \quad \dots\dots\dots (1)$$

Again, Applying Kvl in loop 2nd:-

$$-8I_2 - 5I_2 - 12I_2 + 8I_1 = 0$$

$$8I_1 - 25I_2 = 0 \quad \dots\dots\dots (2)$$

On solving,eqn (1) & eqn (2), We get

$$I_1 = 0.524 \text{ A}$$

$$I_2 = 0.167 \text{ A}$$

Now, From the circuit $V_{o.c}$ is

$$V_A - 5I_2 - V_B = 0$$

$$V_{o.c} / V_{AB} = 5I_2 = 5 \times 0.167 = 0.835 \text{ v}$$

So, the maximum power through the R_L is given by:-

$$P_{\max} = \frac{V_{o.c}^2}{4R_L}$$

$$P_{\max} = \frac{0.835^2}{4 \times 3.77}$$

$$P_{\max} = 0.046 \text{ watt}$$

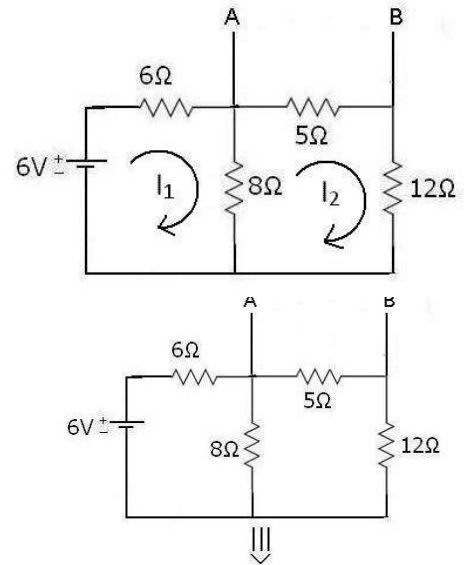

Milliman's Theorem

This theorem states that Any number of current sources in parallel may be replaced by a single current source whose current is the algebraic sum of individual source currents and source resistance is the parallel combination of individual source resistance.

The alternative statement of Milliman's theorem is Any number of voltage source $V_1, V_2, V_3, \dots, V_n$ having source resistance $R_1, R_2, R_3, \dots, R_n$ respectively connected in parallel may be replaced by a single voltage source V_n and resistance R_n where

$$V_n = \frac{1}{G_1 + G_2 + \dots + G_n} \quad \text{where } G_1 = \frac{1}{R_1}, G_2 = \frac{1}{R_2} \text{ etc.}$$

The above two statements are identical because a voltage source can be connected in to current source and vice-versa.

Reciprocity Theorem

The Reciprocity theorem states that if the source voltage and zero resistance ammeters are integrated, the magnitude of the current through the ammeter will be the same. In lead the principle states that in a linear positive network, supply voltage V and current I are mutually transferable. The ratio of V and I is called the transfer resistance.

Problem 1

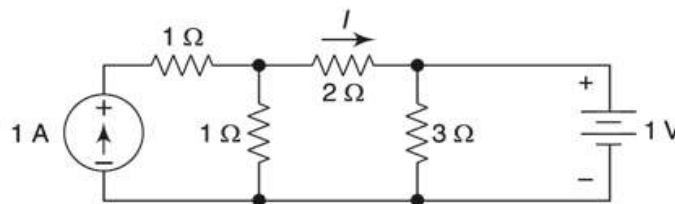

Find the current I in the circuit shown in the figure. using superposition theorem.

Solution

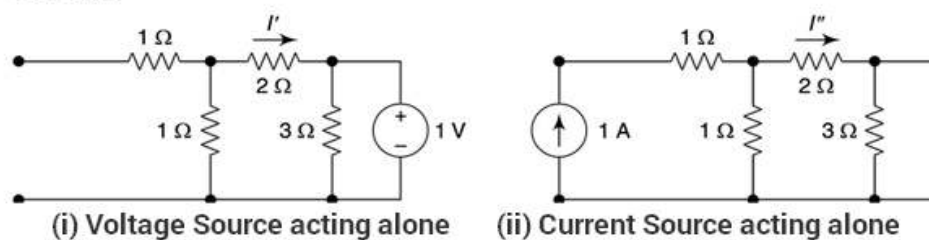

For Figure (i) $I' = -\frac{1}{3} \text{ A}$

For Figure (ii) $I'' = 1 \times \frac{1}{1+2} = \frac{1}{3} \text{ A}$

By superposition, $I = (I' + I'') = -\frac{1}{3} + \frac{1}{3} = 0$

Problem 2

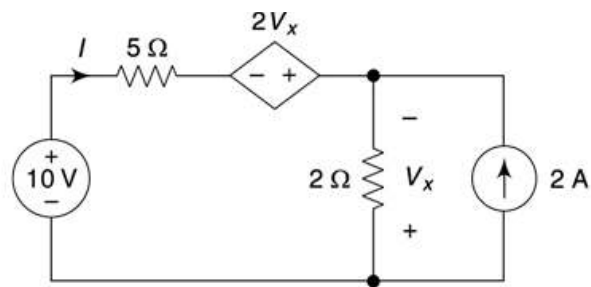

Use superposition theorem on the circuit shown in figure to find I .

Solution

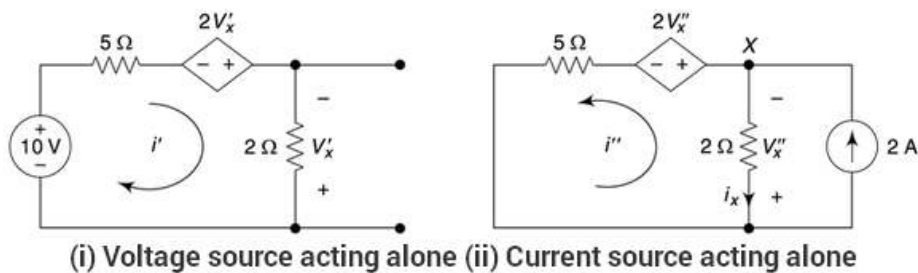

For Fig. (i), by KVL, $5i' - 2v_x' + 2i' = 10$ with $v_x' = -2i'$

$$\Rightarrow 7i' + 4i' = 10$$

$$\Rightarrow i' = 10/11 \text{ A}$$

For Fig (ii), by KCL at node (x)

$$2 = i_x + i'' = -\frac{v_x''}{2} + i'' \quad (i)$$

But loop analysis in the left loop gives,

$$5i'' + 3v_x'' = 0$$

$$\text{or } i'' = -\frac{3}{5}v_x''$$

$$\text{From (i), } 2 = -\frac{v_x''}{2} - \frac{3}{5}v_x''$$

$$\Rightarrow v_x'' = -\frac{20}{11}$$

$$\therefore i'' = -\frac{3}{5} \times \left(-\frac{20}{11}\right) = \frac{12}{11} \text{ A}$$

So, by superposition theorem total current

$$I = (i' - i'') = \left(\frac{10}{11} - \frac{12}{11}\right) = -\frac{2}{11} \text{ A}$$

Problem 3

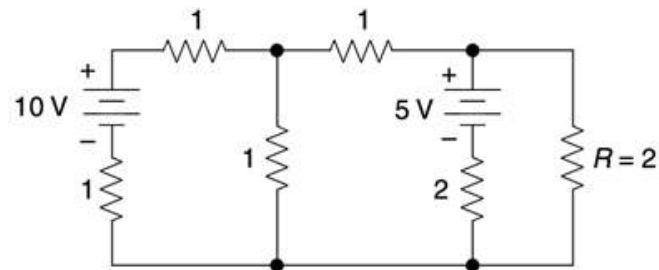

Draw the Thevenin's equivalent of the circuit in figure and find the load current, i . All values are in ohm.

Solution

Open circuiting the terminals,

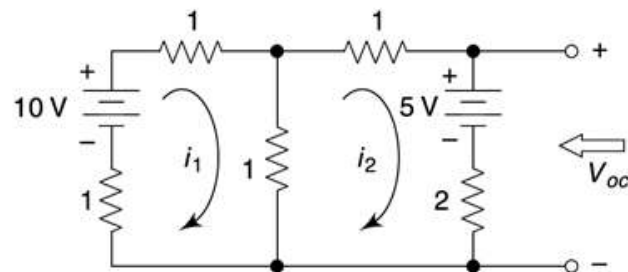

By KVL for two meshes,

$$3i_1 - i_2 = 10$$

$$\text{and } -i_1 + 4i_2 = -5$$

Solving, $i_1 = 5/11$ and $i_2 = -5/11$

$$\therefore V_{oc} = (5 + 2i_2) = \left(5 - \frac{10}{11}\right) = \frac{45}{11} \text{ V}$$

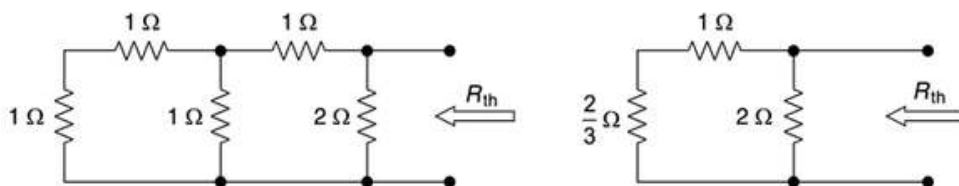

$$\text{Equivalent resistance, } R_{th} = \frac{\frac{5}{3} \times 2}{\frac{5}{3} + 2} = \frac{10}{11} \Omega$$

$$\text{So, the load current is, } i = \frac{V_{oc}}{R_{th} + 2} = \frac{45/11}{10/11 + 2} = \frac{45}{32} = 1.40625 \text{ A}$$

Problem 4

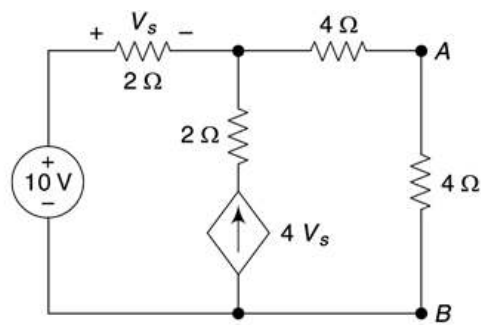

Find Thevenin's equivalent about AB for the circuit shown in figure.

Solution

Open-circuiting The $4\ \Omega$ resistor, by KCL,

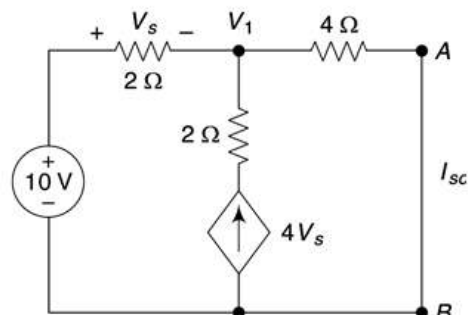
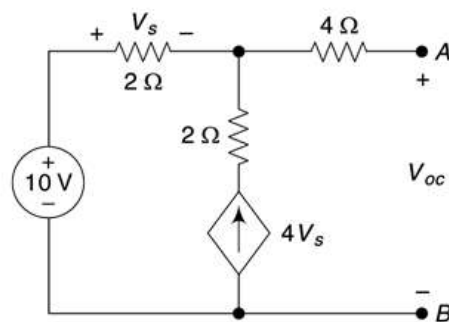

$$\frac{V_{oc} - 10}{2} = 4v_s = 4(10 - V_{oc})$$

$$\Rightarrow V_{oc} = 10\text{ V}$$

Short-circuiting the terminals AB , by KCL,

$$\frac{V_1 - 10}{2} + \frac{V_1}{4} = 4v_s = 4(10 - V_1)$$

$$V_1 = \frac{180}{19} = 9.47\text{ V}$$

$$\therefore I_{sc} = \frac{9.47}{4} = 2.368\text{ A}$$

$$\therefore R_{th} = \frac{V_{th}}{I_{sc}} = 4.22\ \Omega$$

Problem 5

Verify the Reciprocity Theorem for the network shown in the figure using current source and a voltmeter. All the values are in ohm.

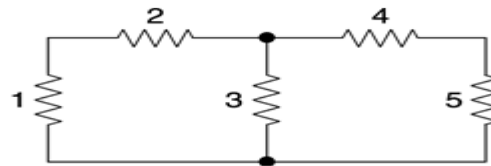

Solution

Using a current source and a voltmeter,

Let, e_1, e_2 be node voltages, v_1 be the voltmeter reading.

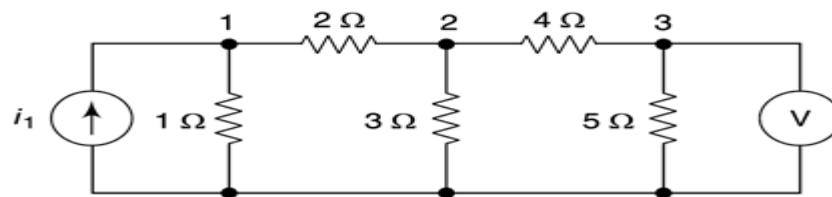

By KCL,

$$\text{At node (1)} \Rightarrow 3e_1 - e_2 - 2i_1 = 0 \quad (\text{i})$$

$$\text{At node (2)} \Rightarrow -6e_1 + 13e_2 - 3v_1 = 0 \quad (\text{ii})$$

$$\text{At node (3)} \quad 9v_1 = 5e_2 \quad (\text{iii})$$

$$\text{From (ii)} \Rightarrow -6e_1 + 13 \times \frac{9}{5} v_1 - 3v_1 = 0$$

$$\Rightarrow -6e_1 + \left(\frac{117}{5} - 3 \right) v_1 = 0$$

$$\Rightarrow 6e_1 + \frac{102}{5} v_1 \Rightarrow e_1 = \frac{17}{5} v_1$$

$$\text{From (i)} \Rightarrow 3 \times \frac{17}{5} v_1 - \frac{9}{5} v_1 = 2i_1$$

$$\Rightarrow \begin{pmatrix} i_1 \\ v_1 \end{pmatrix} = \begin{pmatrix} 21 \\ 5 \end{pmatrix} \text{ (A)}$$

Interchanging the positions of the current source and the voltmeter,

Now, let v_2 be the voltmeter reading

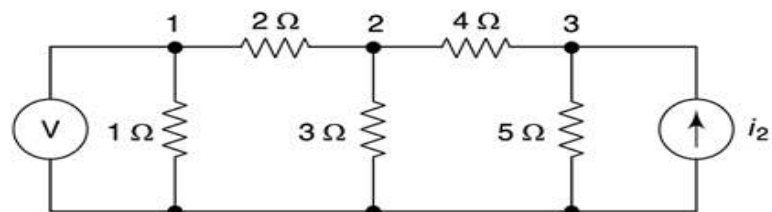

By KCL,

$$\text{At node (1)} \Rightarrow 3v_2 = e_2 \text{ (iv)}$$

$$\text{At node (2)} \Rightarrow -6v_2 + 13e_2 - 3e_3 = 0$$

$$\Rightarrow -6v_2 + 13 \times 3v_2 - 3e_3 = 0$$

$$\Rightarrow e_3 = 11v_2 \text{ (v)}$$

$$\text{At node (3)} \Rightarrow 5e_3 - 5e_2 + 4e_3 - 20i_2 = 0$$

$$\Rightarrow 20i_2 = 9e_3 - 5e_2 = 9 \times 11v_2 - 5 \times 3v_2 = 84v_2$$

$$\Rightarrow \left(\frac{i_2}{v_2} \right) = \left(\frac{21}{5} \right) \text{ (B)}$$

From equations (A) and (B), Reciprocity theorem is proved.

Problem 6

Find the load current using Millman's theorem. All values are in ohm.

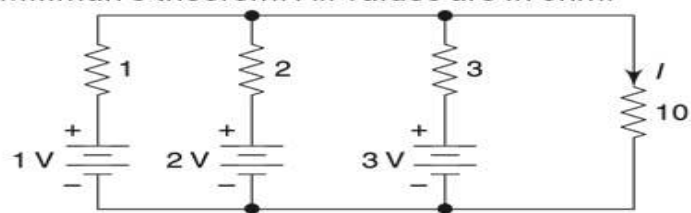

Solution

Here, $E_1 = 1 \text{ V}$, $E_2 = 2 \text{ V}$, $E_3 = 3 \text{ V}$

$$Z_1 = 1 \ \Omega, Z_2 = 2 \ \Omega, Z_3 = 3 \ \Omega$$

$$\therefore Y_1 = 1 \ \text{S}, Y_2 = 0.5 \ \text{S}, Y_3 = \frac{1}{3} \ \text{S}$$

By Millman's theorem, the equivalent circuit is shown.

$$\therefore E = \frac{\sum_{i=1}^3 E_i Y_i}{\sum_{i=1}^3 Y_i} = \frac{1 \times 1 + 2 \times 0.5 + 3 \times \frac{1}{3}}{1 + 0.5 + \frac{1}{3}} = \frac{3}{\frac{6}{3}} = \frac{18}{11} \text{ V}$$

$$\text{and } Z = \frac{1}{\sum_{i=1}^3 Y_i} = \frac{6}{11} \ \Omega$$

$$\therefore I = \frac{E}{Z + 10} = \frac{\frac{18}{11}}{\frac{6}{11} + 10} = \frac{18}{116} = \frac{9}{58} \text{ A}$$



CHAPTER-3

AC FUNDAMENTAL & AC CIRCUIT

WHAT IS ALTERNATING CURRENT (A.C.)

Alternating current is the current which constantly changes in amplitude, and reverses direction at regular intervals. We know that direct current flows only in one direction, and that the amplitude of current is determined by the number of electrons flowing past a point in a circuit in one second. If, for example, a coulomb of electrons moves past a point in a wire in one second and all of the electrons are moving in the same direction, the amplitude of direct current in the wire is one ampere. Similarly, if half a coulomb of electrons moves in one direction past a point in the wire in half a second, then reverses direction and moves past the same point in the opposite direction during the next half-second, a total of one coulomb of electrons passes the point in one second. The amplitude of the alternating current is one ampere.

PROPERTIES OF ALTERNATING CURRENT

An A.C. source of electrical power changes constantly in amplitude and the changes are so regular. Alternating voltage and current have a number of properties associated with any such waveform. These basic properties include the following list:

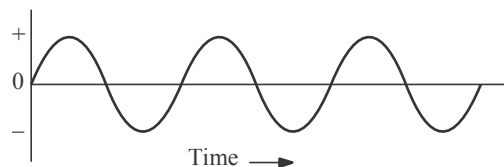

Frequency

One of the most important properties of any regular waveform identifies the number of complete cycles it goes through in a fixed period of time. For standard measurements, the period of time is one second, so the frequency of the wave is commonly measured in cycles per second (cycles/sec) and, in normal usage, is expressed in units of Hertz (Hz). It is represented in mathematical equations by the letter '*f*'.

Period

Sometimes we need to know the amount of time required to complete one cycle of the waveform, rather than the number of cycles per second of time. This is logically the reciprocal of frequency

Wavelength

Because an A.C. wave moves physically as well as changing in time, sometimes we need to know how far it moves in one cycle of the wave, rather than how long that cycle takes to complete. This of course depends on how fast the wave is moving as well. The Greek letter (λ) is used to represent wavelength in mathematical expressions. And, $\lambda = c/f$. As shown in the figure to the above, wavelength can be measured from any part of one cycle to the equivalent point in the next cycle. Wavelength is very similar to period as discussed above, except that wavelength is measured in distance per cycle while period is measured in time per cycle.

Amplitude

Mathematically, the amplitude of a sine wave is the value of that sine wave at its peak. This is the maximum value, positive or negative, that it can attain. However, when we speak of an A.C. power system, it is more useful to refer to the effective voltage or current.

THE SINE WAVE

In discussing alternating current and voltage, you will often find it necessary to express the current and voltage in terms of maximum or peak values, peak-to-peak values, effective values, average values, or instantaneous values. Each of these values has a different meaning and is used to describe a different amount of current or voltage.

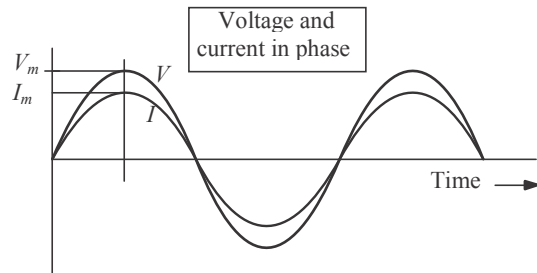

Fig. 1.6

Peak Value [Ip]

Refer to figure, it is the maximum value of voltage [V_p] or Current [I_p]. The peak value applies to both positive and negative values of the cycle.

Peak-Peak value [Ip-p]

During each complete cycle of ac there are always two maximum or peak values, one for the positive half-cycle and the other for the negative half-cycle. The difference between the peak positive value and the peak negative value is called the peak-to-peak value of the sine wave. This value is twice the maximum or peak value of the sine wave and is sometimes used for measurement of ac voltages.

Note the difference between peak and peak-to-peak values in the figure. Usually alternating voltage and current are expressed in effective values rather than in peak-to-peak values.

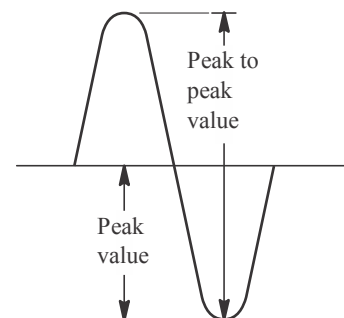

INSTANTANEOUS VALUE

The instantaneous value of an alternating voltage or current is the value of voltage or current at one particular instant. The value may be zero if the particular instant is the time in the cycle at which the polarity of the voltage is changing. It may also be the same as the peak value, if the selected instant is the time in the cycle at which the voltage or current stops increasing and starts decreasing.

There are actually an infinite number of instantaneous values between zero and the peak value.

AVERAGE VALUE

The average value of an alternating current or voltage is the average of all the instantaneous values during one alternation. Since the voltage increases from zero to peak value and decreases back to zero during one alternation, the average value must be some value between those two limits.

The average value of A.C. is the average over one complete cycle and is clearly zero, because there are alternately equal positive and negative half cycles.

$$\text{Average voltage} = \frac{2}{\pi} \times \text{peakvalue}$$

ROOT MEAN SQUARE VALUE

Circuit currents and voltage in A.C. circuits are generally stated as root-mean-square or rms values rather than by quoting the maximum values. The root-mean-square for a current is defined as the value of steady state current which when flowing through a resistor for a given time produces the same amount of heat generated by the alternating current when passed through the same resistor for the same time.

$$I_{rms} = \sqrt{\frac{1}{T} \int_0^T i^2 dt} \qquad I_{rms} = \frac{I_m}{\sqrt{2}}$$

$$\text{Form Factor} = \frac{V_{rms}}{V_{ave}} = 1.11$$

It is the ratio of RMS value to average value of voltage or current.

SINE WAVES IN PHASE

When a sine wave of voltage is applied to a pure resistance, the resulting current is also a sine wave. This follows Ohm's law which states that current is directly proportional to the applied voltage. To be in phase, the two sine waves must go through their maximum and minimum points at the same time and in the same direction as shown in the figure.

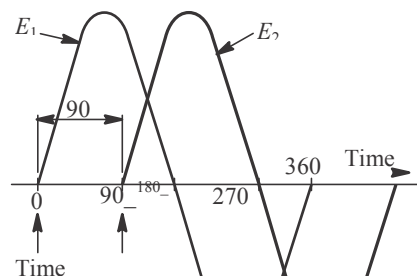
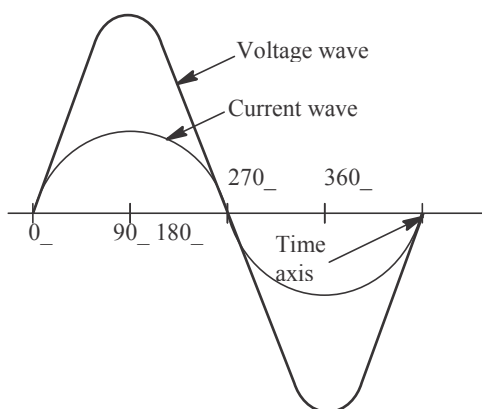

Sine Waves Out of Phase

Figure shows voltage wave E_1 which is considered to start at 0° (time one). As voltage wave E_1 reaches its positive peak, voltage wave E_2 starts its rise (time two). Since these voltage waves do not go through their maximum and minimum points at the same instant of time, a phase difference exists between the two waves. The two waves are said to be out of phase. For the two waves in figure, the phase difference is 90° .

PHASORS

In an a.c. circuit, the e.m.f. or current vary sinusoidally with time and may be mathematically represented as

$$E = E_0 \sin \omega t$$

and

$$I = I_0 \sin (\omega t \pm \theta)$$

Where θ is the phase angle between alternating e.m.f. and current.

Displacement of S.H.M. also varies sinusoidally with time *i.e.*

$$Y = A \sin \omega t$$

And its instantaneous value is equal to the projection of the amplitude A on Y -axis. Therefore, instantaneous values of alternating e.m.f. (E) and current (I) may be considered as the projections of e.m.f. amplitude (E_0) and current amplitude (I_0) respectively. The quantities, such as alternating e.m.f. and alternating current are called phasor. Thus a phasor is a quantity which varies sinusoidally with time and represented as the projection of rotating vector.

PHASOR DIAGRAM

The generator at the power station which produces our A.C. mains rotates through 360 degrees to produce one cycle of the sine wave form which makes up the supply.

In the next diagram there are two sine waves.

They are out of phase because they do not start from zero at the same time.

To be in phase they must start at the same time.

The waveform A starts before B and is LEADING by 90 degrees.

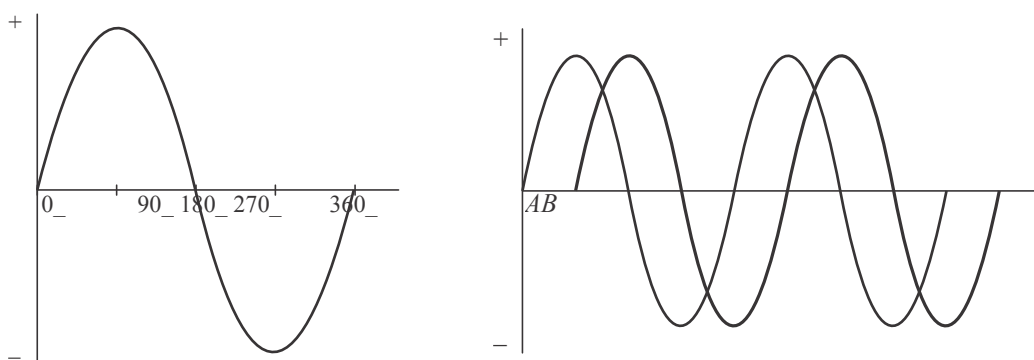

Waveform B is LAGGING A by 90 degrees.

The next left hand diagram, known as a PHASOR DIAGRAM, shows this in another way.

It is sometimes helpful to treat the phase as if it defines a vector in a plane. The usual reference for zero phase is taken to be the positive x-axis and is associated with the resistor since the voltage and current associated with the resistor are in phase. The length of the phasor is proportional to the magnitude of the quantity represented, and its angle represents its phase relative to that of the current through the resistor. The phasor diagram for the RLC series circuit shows the main features.

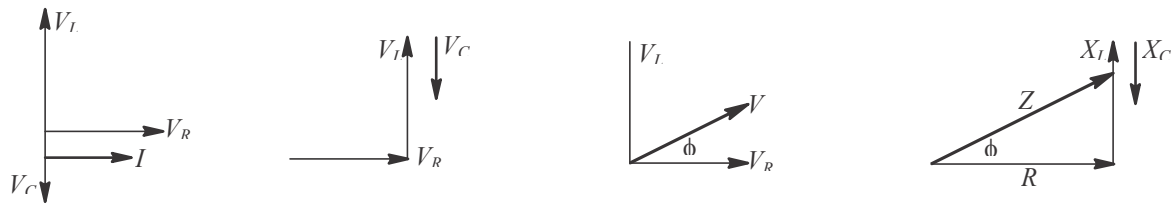

Note that the phase angle, the difference in phase between the voltage and the current in an A.C. circuit, is the phase angle associated with the impedance Z of the circuit.

AC SERIES CIRCUIT

RESISTANCE AC CIRCUIT

A resistance R connected to an ac source is shown. Its voltage can be written as

$$e_t = E_m \sin \omega t$$

$$i = I_m \sin \omega t$$

$$i = \frac{E_m}{R} \sin \omega t = I_m \sin \omega t$$

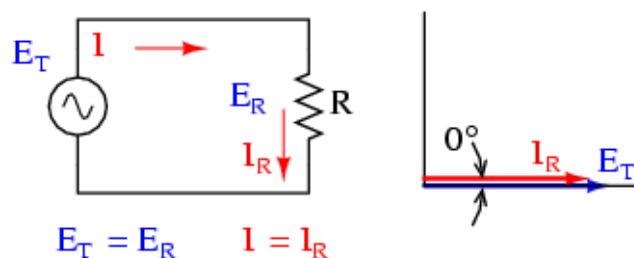

The above two equations depict that voltage and current in resistive network are in phase. Figure shows the voltage and current waveform and phasor diagram.

POWER IN RESISTIVE NETWORK

The instantaneous power curve is plotted in figure it is seen that the power curve is always positive in case of resistive network and equal to

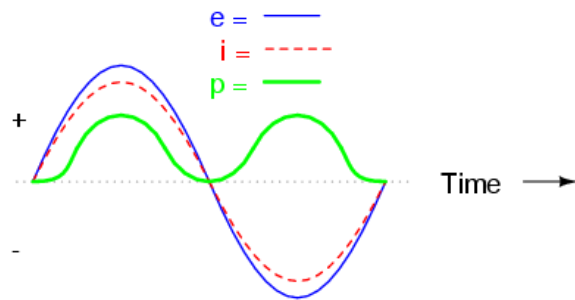

$$p = e_i \times i = E_{im} I_m \sin^2 \omega t = E_{im} I_m \left(\frac{1 - \cos 2\omega t}{2} \right) = \frac{E_{im} I_m}{2} - \frac{E_{im} I_m}{2} \cos 2\omega t$$

The above power equation shows that the power has two components, one is constant i.e. $\frac{E_{im} I_m}{2}$ & an ac component $\frac{E_{im} I_m}{2} \cos 2\omega t$. The average value of ac component

in one cycle is zero. Therefore Average power $p = \frac{E_{im} I_m}{2} = \frac{E_{im}}{\sqrt{2}} \times \frac{I_m}{\sqrt{2}} = E_r I$

Inductance AC Circuit

Figure shows an inductance L connected to an ac supply which voltage is given by $v = E_{Tm} \sin \omega t$, $i =$

$$I_m \sin \left(\omega t - \frac{\pi}{2} \right)$$

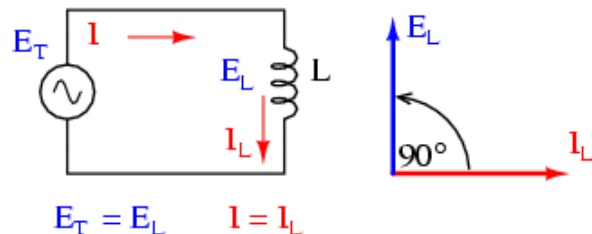

The above equation shows

that current lags the applied voltage by 90° Where $I_m = \frac{E_{Tm}}{\omega L}$, the quantity ωL controls the current inductor and this quantity ωL is known as inductive reactance denoted X_L . Hence $X_L = \omega L$

POWER IN INDUCTIVE NETWORK

The instantaneous power in a purely inductive network is

$$\begin{aligned} p &= e_r \times i = E_{Tm} \sin \omega t \times I_m \sin \left(\omega t - \frac{\pi}{2} \right) \\ &= -E_{Tm} I_m \sin \omega t \cdot \cos \omega t \\ &= \frac{-E_{Tm} I_m \sin 2\omega t}{2} \end{aligned}$$

The average power in a pure inductor during a cycle is zero.

CAPACITANCE IN AC CIRCUIT

Figure shows a capacitor C connected to an ac source equation of voltage & current are given below

$$v = V_m \sin \omega t, \quad I_m \sin \left(\omega t + \frac{\pi}{2} \right)$$

Equation shows that current leads voltage by 90° and $I_m = \frac{V_m}{\frac{1}{\omega C}}$ Where $\frac{1}{\omega C}$ is known as

capacitive reactance denoted as X_C . Its unit is ohm.

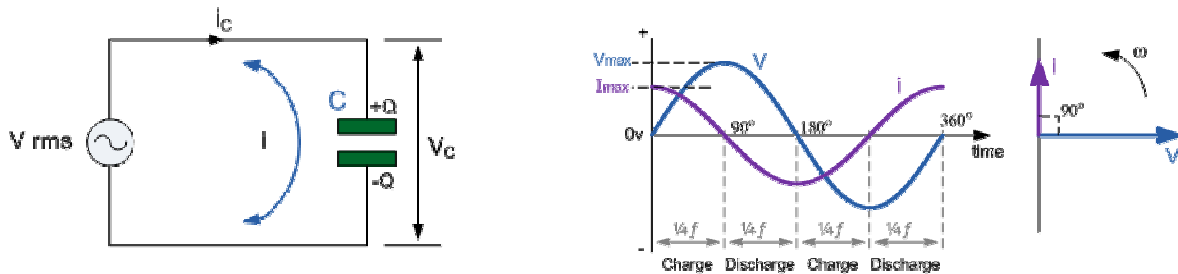

POWER IN CAPACITIVE NETWORK

The instantaneous power in a purely capacitive network is

$$p = v \times i = V_m \sin \omega t \times I_m \sin \left(\omega t + \frac{\pi}{2} \right)$$

$$= \frac{V_m I_m \sin 2\omega t}{2}$$

The average power in a pure capacitive network is zero.

SERIES RL NETWORK

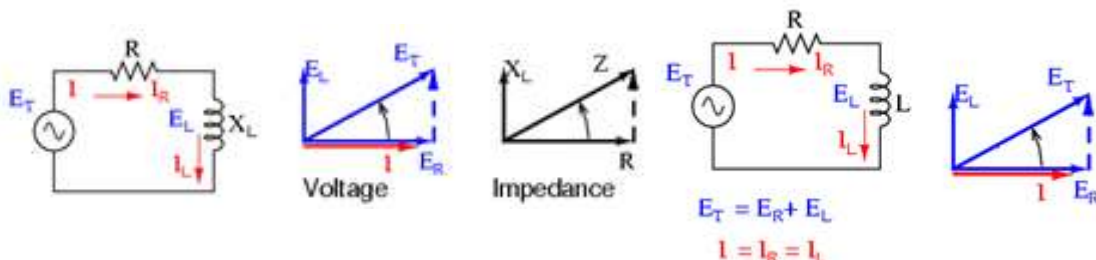
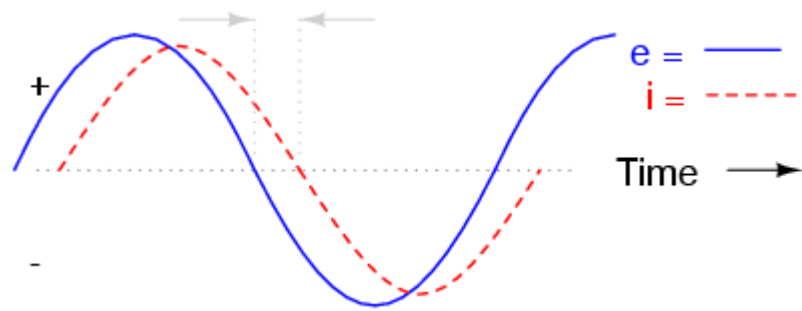

Figure shows a resistor (R) and inductor (L) series network with its phasor diagram and impedance diagram. As discussed earlier E_R is in phase with I and E_L leads I by 90° .



$$E_T = E_L + E_R = I(R + jX_L)$$

Hence $\Rightarrow IZ = I(R + jX_L)$

$$\Rightarrow Z = (R + jX_L) = R + j\omega L$$

Where magnitude of $Z = \sqrt{R^2 + X_L^2}$

The quantities R, X_L, Z are shown in the impedance diagram.

POWER IN SERIES RL NETWORK

The average power in RL series circuit is

$$p = \frac{E_{Tm} I_m}{2} \cos \theta = \frac{E_{Tm}}{\sqrt{2}} \cdot \frac{I_m}{\sqrt{2}} \cos \theta = E_T I \cos \theta$$

$E_T I \cos \theta$ is known as active power. $p = E_T I \cos \theta = E_T I \frac{R}{Z} = \frac{E_T}{Z} \cdot IR = I^2 R \therefore I = \frac{E_T}{Z}$

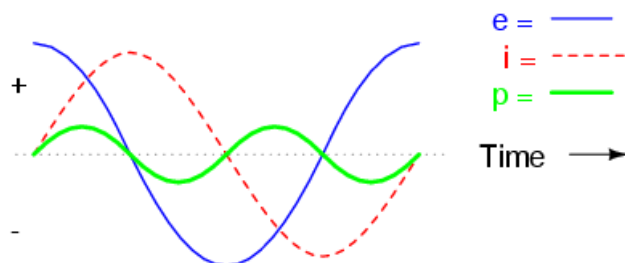

Thus the active power in ac circuit represents the power dissipated across resistance. It is measured in watt. The product of RMS voltage & current i.e. VI is known as apparent power and measured in volt ampere. The ration of active power to apparent power equals to $\cos \theta$ where θ is the phase angle between V & I. The term $\cos \theta$ is called

power factor of the circuit. The power factor is zero in case of pure inductive or capacitive network. The power factor of a circuit may be either leading or lagging. A leading power factor means that the current in the circuit leads the voltage and lagging power factor means the current lags the voltage. The power factor of a circuit is the ratio of resistance to impedance .

The instantaneous power across inductor or capacitor is known as reactive power. That is $Q = I^2 X_L = I^2 \omega L = I^2 Z \sin \theta = E_T I \sin \theta$

The reactive power does not contribute anything to the net energy transfer from source to load. Yet it constitutes a loading of the equipment.

The apparent power VI , active power $VI \cos \theta$ and reactive power $VI \sin \theta$ is also applicable in this case too. Current in RC circuit leads the apply voltage and therefore the power factor is leading.

SERIES RC NETWORK

Figure shows a series RC network

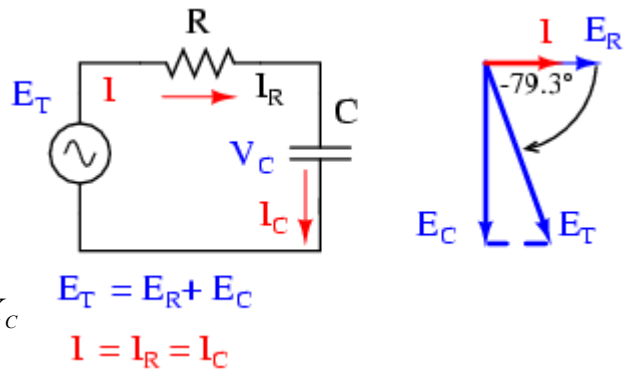

$$E_T = RI - j \frac{I}{\omega C} = I \left(R - \frac{j}{\omega C} \right)$$

$$\Rightarrow IZ = I \left(R - \frac{j}{\omega C} \right) \Rightarrow Z = R - \frac{j}{\omega C} = R - jX_C$$

$$X_C = \text{Capacitive Reactance} = \frac{1}{\omega C}$$

$$\text{magnitude of } Z = \sqrt{R^2 + \frac{1}{\omega^2 C^2}}$$

SERIES R-L-C CIRCUIT

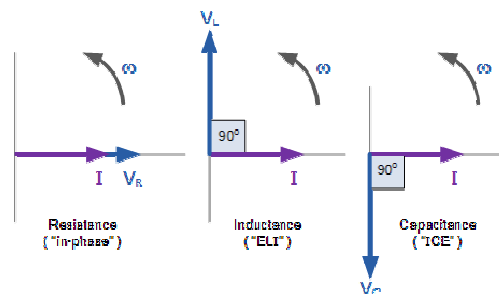
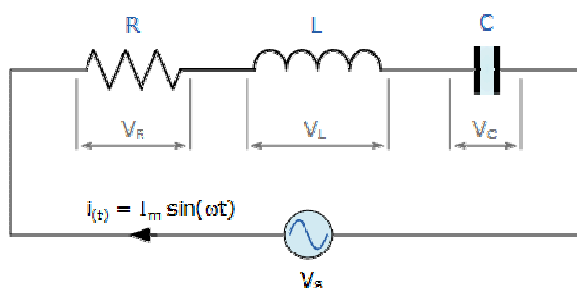

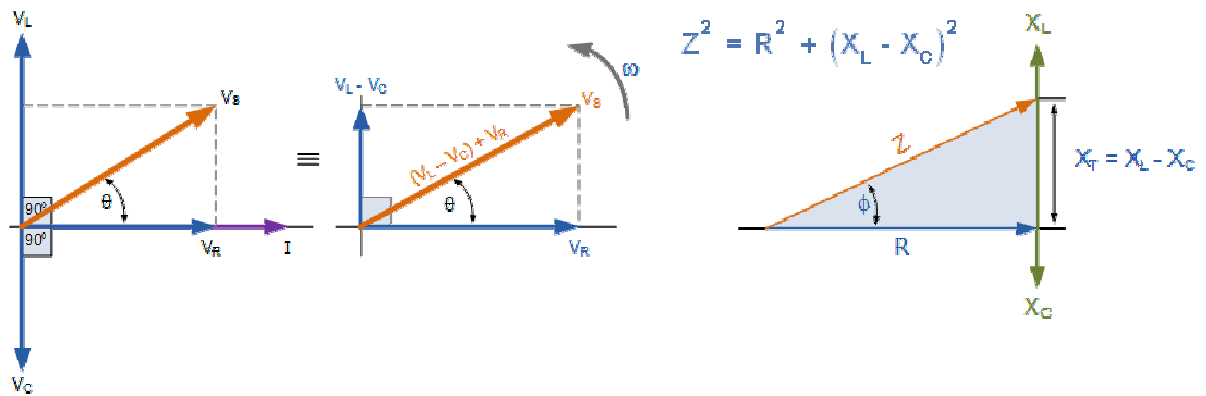

Consider a series R-L-C circuit as shown in the figure. The voltage V_R is in phase with the current, the voltage V_L leads the current by 90° and the voltage V_C lags the current by 90° . The total impedance

$$\begin{aligned} Z &= Z_R + Z_L + Z_C \\ &= R + j(X_L - X_C) \end{aligned}$$

We can find that the reactance is positive if $X_L > X_C$ and negative if $X_C > X_L$. If $X_L > X_C$ the circuit behaves like an R-L series circuit and current lags voltage by an angle θ if $X_C > X_L$ the circuit behaves as an R-C series circuit and current leads the applied voltage by angle θ . The phasor diagram for both cases are shown.

The magnitude of the impedance is given by

$$|Z| = \sqrt{R^2 + (X_L - X_C)^2} \quad i = \frac{vS}{z}$$

$$\theta = \tan^{-1} \frac{\omega L - \frac{1}{\omega C}}{R}$$



CHAPTER-4

RESONANCE

Consider a series R-L-C circuit as shown in the figure. The impedance of the circuit is given by

$$Z = R + j(X_L - X_C)$$

where X_L is inductive reactance = ωL and $X_C =$ capacitive reactance = $\frac{1}{\omega C}$.

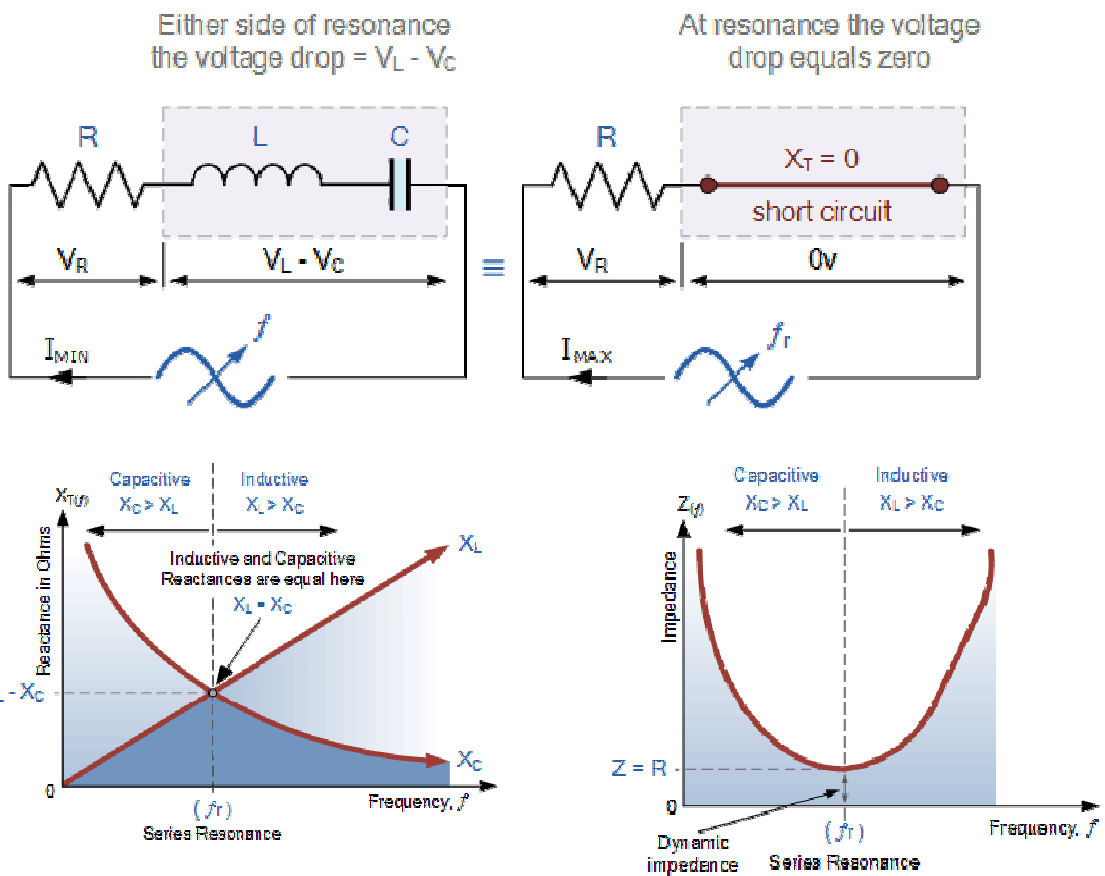
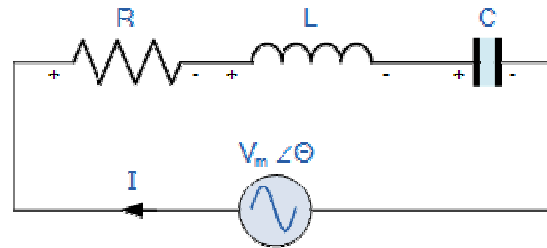

As frequency of the supply is increased X_L increases and X_C decreases. At one particular frequency $X_L = X_C$ and the total reactance of the circuit become zero. At this particular frequency the impedance is resistive and voltage & current are in phase. This phenomenon is known as resonance.

$$\begin{aligned} X_L &= X_C \\ \Rightarrow 2\pi f_0 L &= \frac{1}{2\pi f_0 C} \\ \Rightarrow f_0 &= \frac{1}{2\pi\sqrt{LC}} \end{aligned}$$

f_0 is called as frequency of resonance. Impedance Z of the R-L-C series circuit is equal to R at resonance and current is equal to $\frac{V}{R}$.

Q Factor

The ratio of capacitor voltage or inductor voltage at resonant frequency to supply voltage is a measure of quality of a resonance circuit. This term is known as quality factor (Q factor).

At the frequency of the resonance (f_0)

$$V_L = IX_L = \frac{V}{R} X_L \therefore I = \frac{V}{R}$$

$$Q = \frac{V_L}{V} = \frac{X_L}{R} = \frac{2\pi f_0 L}{R}$$

$$= \frac{V_C}{V} = \frac{X_C}{R} = \frac{1}{2\pi f_0 RC}$$

Bandwidth

At resonant frequency current in the R-L-C series circuit is maximum. Let us define two frequencies w_1 & w_2 at which current is $0.707I_{max}$. The frequency w_1 & w_2 are called half power frequency.

$$\text{Bandwidth} = w_2 - w_1$$

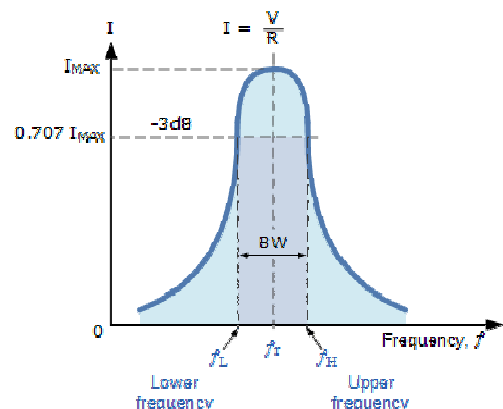

Where w_2 = upper half power frequency, w_1 = lower half power frequency.

Relationship between Q and Bandwidth of R-L-C series circuit

$$\text{Bandwidth} = w_2 - w_1$$

At $w = w_1$, the reactance is capacity as $X_C > X_L$

$$\text{Hence } \frac{1}{w_1 C} - w_1 L = R \dots\dots\dots \text{eq.1}$$

At $w = w_2$ the reactance is inductive as $X_L > X_C$

$$\text{Hence } w_2 L - \frac{1}{w_2 C} = R \dots\dots\dots \text{eq. 2}$$

From equation1 we get $w_1^2 LC + w_1 RC - 1 = 0$

Dividing by LC we get $w_1^2 + w_1 \frac{R}{L} - \frac{1}{LC} = 0$

$$w_1 = \frac{-R}{2L} \pm \sqrt{\frac{R^2}{4L^2} + \frac{1}{LC}}$$

Similarly from equation 2

$$w_2^2 - \frac{R}{L} w_2 - \frac{1}{LC} = 0$$

$$w_2 = \frac{R}{2L} \pm \sqrt{\frac{R^2}{4L^2} + \frac{1}{LC}}$$

Hence bandwidth

$$w_2 - w_1 = \frac{R}{2L} + \frac{R}{2L} = \frac{R}{L}$$

$$\Rightarrow 2\pi(f_2 - f_1) = \frac{R}{L}$$

$$\Rightarrow f_2 - f_1 = \frac{R}{2\pi L} = \frac{f_0}{Q}$$

$$\Rightarrow Q = \frac{f_0}{f_2 - f_1} = \frac{w_0}{BW}$$

The Parallel Resonance Circuit

In many ways a **parallel resonance** circuit is exactly the same as the series resonance circuit we looked at in the previous tutorial. Both are 3-element networks that contain two reactive components making them a second-order circuit, both are influenced by variations in the supply frequency and both have a frequency point where their two reactive components cancel each other out influencing the characteristics of the circuit. Both circuits have a resonant frequency point.

The difference this time however, is that a parallel resonance circuit is influenced by the currents flowing through each parallel branch within the parallel LC tank circuit. A tank circuit is a parallel combination of L and C that is used in filter networks to either select or reject AC frequencies. Consider the parallel RLC circuit below.

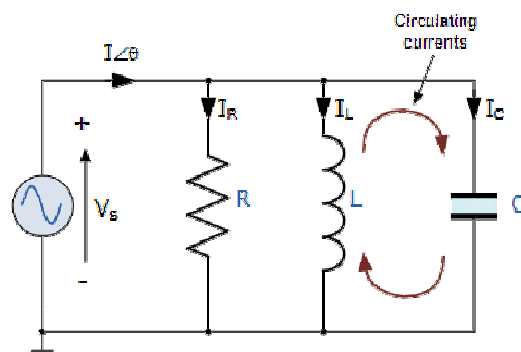

Let us define what we already know about parallel RLC circuits.

$$\text{Admittance, } Y = \frac{1}{Z} = \sqrt{G^2 - B^2}$$

$$\text{Conductance, } G = \frac{1}{R}$$

$$\text{Inductive Susceptance, } B_L = \frac{1}{2\pi fL}$$

$$\text{Capacitive Susceptance, } B_C = 2\pi fC$$

A parallel circuit containing a resistance, R, an inductance, L and a capacitance, C will produce **parallel resonance** (also called anti-resonance) circuit when the resultant current through the parallel combination is in phase with the supply voltage. At resonance there will be a large circulating current between the inductor and the capacitor due to the energy of the oscillations, then parallel circuits produce current resonance.

A *parallel resonant circuit* stores the circuit energy in the magnetic field of the inductor and the electric field of the capacitor. This energy is constantly being transferred back and forth between the inductor and the capacitor which results in zero current and energy being drawn from the supply. This is because the corresponding instantaneous values of I_L and I_C will always be equal and opposite and therefore the current drawn from the supply is the vector addition of these two currents and the current flowing in I_R .

In the solution of AC parallel resonance circuits we know that the supply voltage is common for all branches, so this can be taken as our reference vector. Each parallel branch must be treated separately as with series circuits so that the total supply current taken by the parallel circuit is the vector addition of the individual branch currents. Then there are two methods available to us in the analysis of parallel resonance circuits. We can calculate the current in each branch and then add together or calculate the admittance of each branch to find the total current.

We know from the previous series resonance tutorial that resonance takes place when $V_L = -V_C$ and this situation occurs when the two reactance are equal, $X_L = X_C$. The admittance of a parallel circuit is given as:

$$Y = G + B_L + B_C$$

$$Y = \frac{1}{R} + \frac{1}{j\omega L} + j\omega C$$

or

$$Y = \frac{1}{R} + \frac{1}{2\pi fL} + 2\pi fC$$

Resonance occurs when $X_L = X_C$ and the imaginary parts of Y become zero.

Then:

$$X_L = X_C \Rightarrow 2\pi fL = \frac{1}{2\pi fC}$$

$$f^2 = \frac{1}{2\pi L \times 2\pi C} = \frac{1}{4\pi^2 LC}$$

$$f = \sqrt{\frac{1}{4\pi^2 LC}}$$

$$\therefore f_r = \frac{1}{2\pi\sqrt{LC}} \text{ (Hz)} \text{ or } \omega_r = \frac{1}{\sqrt{LC}} \text{ (rads)}$$

Notice that at resonance the parallel circuit produces the same equation as for the series resonance circuit. Therefore, it makes no difference if the inductor or capacitor is connected in parallel or series. Also at resonance the parallel LC tank circuit acts like an open circuit with the circuit current being determined by the resistor, R only. So the total impedance of a parallel resonance circuit at resonance becomes just the value of the resistance in the circuit and $Z = R$ as shown.

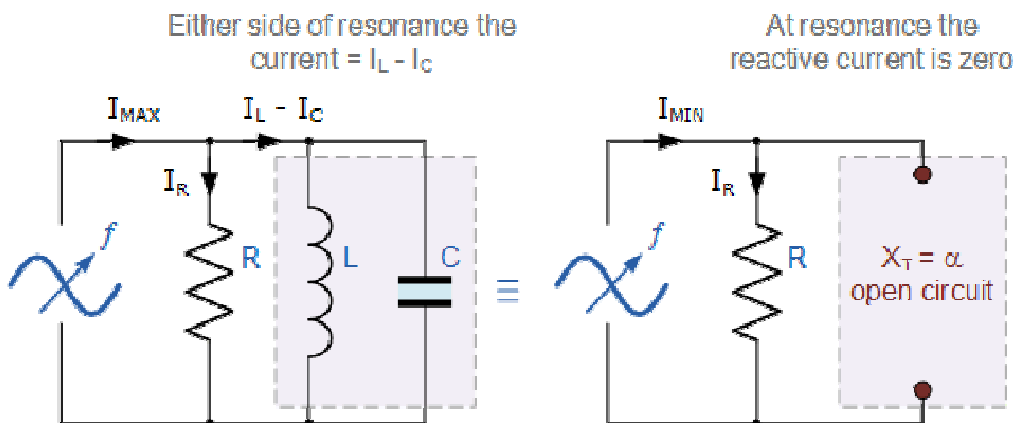

Impedance in a Parallel Resonance Circuit

Note that if the parallel circuit's impedance is at its maximum at resonance then consequently, the circuit's admittance must be at its minimum and one of the characteristics of a parallel resonance circuit is that admittance is very low limiting circuits current. Unlike the series resonance circuit, the resistor in a parallel resonance circuit has a damping effect on the circuit's bandwidth making the circuit less selective.

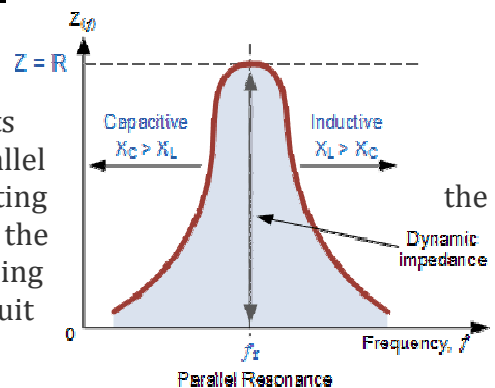

Also, since the circuit current is constant for any value of impedance, Z , the voltage across a parallel resonance circuit will have the same shape as the total impedance and for a parallel circuit the voltage waveform is generally taken from across the capacitor.

We now know that at the resonant frequency, f_r the admittance of the circuit is at its minimum and is equal to the conductance, G given by $1/R$ because in a parallel resonance circuit the imaginary part of admittance, i.e. the susceptance, B is zero because $B_L = B_C$ as shown.

Bandwidth & Selectivity of a Parallel Resonance Circuit

The bandwidth of a parallel resonance circuit is defined in exactly the same way as for the series resonance circuit. The upper and lower cut-off frequencies given as: f_{upper} and f_{lower} respectively denote the half-power frequencies where the power dissipated in the circuit is half of the full power dissipated at the resonant frequency $0.5(I^2 R)$ which gives us the same -3dB points at a current value that is equal to 70.7% of its maximum resonant value, $(0.707 \times I) R$.

As with the series circuit, if the resonant frequency remains constant, an increase in the quality factor, Q will cause a decrease in the bandwidth and likewise, a decrease in the quality factor will cause an increase in the bandwidth as defined by: $BW = f_r / Q$ or $BW = f_2 - f_1$.

Also changing the ratio between the inductor, L and the capacitor, C , or the value of the resistance, R the bandwidth and therefore the frequency response of the circuit will be changed for a fixed resonant frequency. This technique is used extensively in tuning circuits for radio and television transmitters and receivers.

The selectivity or **Q-factor** for a parallel resonance circuit is generally defined as the ratio of the circulating branch currents to the supply current and is given as:

$$\text{Quality Factor, } Q = \frac{R}{2\pi fL} = 2\pi fCR = R\sqrt{\frac{C}{L}}$$

Note that the Q-factor of a parallel resonance circuit is the inverse of the expression for the Q-factor of the series circuit. Also in series resonance circuits the Q-factor gives the voltage magnification of the circuit, whereas in a parallel circuit it gives the current magnification.

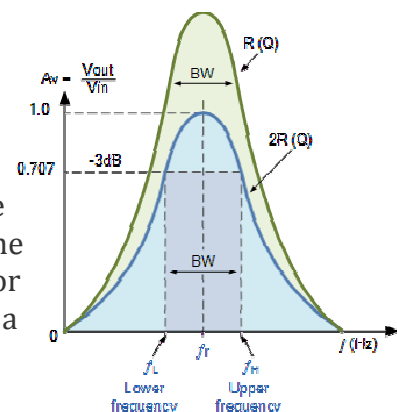

CHAPTER-5

Transient Response of Simple Circuit (DC)

Circuits that contain capacitors and inductors can be represented by differential equation. If a circuit contains one resistor and one Inductor (or one capacitor), it can be represented by first order differential equation. On the other hand if a circuit contains a resistor, inductor and Capacitor it can be represented by a second order differential equation. The solution of the differential equation represents the response of the circuit. The response consists of two parts (1) Transient response (2) Steady State response. The transient response depends on the circuit elements and initial energy stored in it. To obtain the transient response of the network it is necessary to find the initial state of the network.

Initial Condition

Initial condition of a circuit is important to be calculated when a change of state occurs and the change of state of the network occurs when the switch change its position at time $t=0$. The value of voltage, current derivatives of both at $t=0^-$ and $t=0^+$, that is immediately before and after change of switch position. Initial conditions in a circuit depends on the past history of the network prior to $t=0^-$. We will assume that the switch in the network has been in a position for a long time and at $t=0$, the switch changes its position. That is we say the circuit is in steady state at the time of switching.

Initial condition in circuit elements.

1. **Resistor**:- By Ohm's Law we have $V= IR$, if there is a change in voltage, the current through resistance will change simultaneously. Similarly if the current change, voltage across resistance changes simultaneously.
2. **Inductor**:- Current through inductor cannot change instantaneously, if the current through an inductor before switching is zero, then the current through inductor after switching is also zero.

$$\text{i.e. } i_L(0^+) = i_L(0^-) = 0$$

In the same way if the current through inductor before switching is I_0 , then the current through inductor after switching is also I_0 . i.e. $i_L(0^+) = i_L(0^-) = I_0$.

3. **Capacitor**:- Voltage across capacitor cannot change instantaneously. If the voltage across capacitor before switching is zero, then the voltage across capacitor after switching is also zero.

$$V_C(0^+) = V_C(0^-) = 0$$

If the voltage across capacitor prior to switching is V_0 then the voltage across capacitor immediately after switching is

$$V_C(0^+) = V_C(0^-) = V_0$$

The equivalent form of the elements in terms of the initial condition of the elements is shown below.

ELEMENT	EQUIVALENT FORM AT t=0	t=0 ⁺ /EQUATION CIRCUIT AT t= ∞

To solve the initial condition of an element it is necessary to study the steady state behavior of this element. The steady state behavior can be obtained from the basic relations.

$$V_L = L \frac{di}{dt} \quad i_C = C \frac{dv_C}{dt}$$

At $t = \infty$, $V_L = 0$ hence the inductor acts as short-circuit

Similarly at $t = \infty$, $i_L = 0$ hence the capacitor acts as open-circuit.

Example: In the network shown in fig.1, the switch K is called at $t=0$ with the capacitor uncharged. Find the value of i , $\frac{di}{dt}$, $\frac{d^2i}{dt^2}$ at $t = 0^+$.

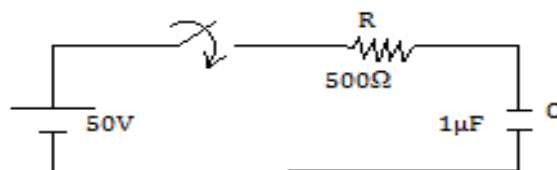

Solution:

Apply KVL to the circuit

$$Ri + \frac{1}{C} \int i dt = V \quad \text{-----eq. (i)}$$

$$\Rightarrow 500i + \frac{1}{1 \times 10^{-6}} \int i dt = 50 \quad \text{-----eq. (ii)}$$

$$V_C(0^+) = V_C(0^-) = 0$$

At $t = 0^+$ $500i(0^+) + 0 = 50$

$$i(0^+) = \frac{50}{500} = 0.1A$$

Differentiating eq. (ii)

$$500 \frac{di}{dt} + i \frac{1}{1 \times 10^{-6}} = 0 \quad \text{-----eq. (iii)}$$

At $t = 0^+$ $500 \frac{di}{dt}(0^+) = -i(0^+) - \frac{1}{1 \times 10^{-6}} = -\frac{1}{1 \times 10^{-6}} \times 0.1$

$$\Rightarrow \frac{di}{dt}(0^+) = -\frac{10^5}{500} = -2000 \text{ Amp/sec.}$$

Differentiating eq. (iii)

$$500 \frac{d^2i}{dt^2} + \frac{1}{1 \times 10^{-6}} \frac{di}{dt} = 0$$

$$\Rightarrow 500 \frac{d^2i}{dt^2}(0^+) = -\frac{1}{1 \times 10^{-6}} \frac{di}{dt}(0^+) = -\frac{1}{1 \times 10^{-6}} (-2000)$$

$$\Rightarrow \frac{d^2i}{dt^2}(0^+) = \frac{2000 \times 10^6}{500} = 4 \times 10^6 \text{ A/sec}^2$$

Transient Response of series R-L circuit having DC Excitation.

Consider a R-L series circuit as shown in figure. The switch is closed at time $t=0$

Applying KVL

$$\frac{L di(t)}{dt} + Ri(t) = V$$

$$\Rightarrow \frac{di(t)}{dt} + \frac{R}{L} i(t) = \frac{V}{L}$$

General solution of the differential equation

$$i(t) = \frac{V}{R} + ke^{-\frac{R}{L}t}$$

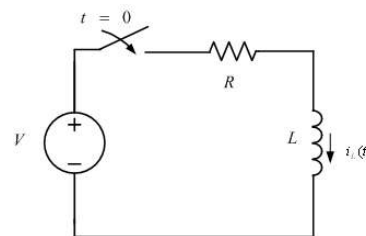

Since inductor behaves as an open circuit as switching

$$i(0^+) = 0$$

$$0 = \frac{V}{R} + K \quad \text{or} \quad K = -\frac{V}{R}$$

$$\text{Therefore } i(t) = \frac{V}{R} - \frac{V}{R} e^{-R/L(t)} = \frac{V}{R} [1 - e^{-(R/L)t}]$$

$$\text{Voltage across inductor } V_L(t) = L \frac{di(t)}{dt} = Ve^{-(R/L)t}$$

$$\text{Voltage across resistor } V_R(t) = V[1 - e^{-(R/L)t}]$$

$$\text{At } t=0, i(t)=0, V_L(t) = V \quad V_R(t)=0$$

$$\text{At } t=\infty, i(t)=\frac{V}{R}, V_L(t)=0, \quad V_R(t)=V$$

$$\text{At } t = \frac{L}{R} \quad i(t) = \frac{V}{R} (1 - e^{-1}) = 0.632 \frac{V}{R}, \quad V_L(t) = 0.368V$$

$i(t)$ & $V(t)$ are plotted in figure.

$\tau = \frac{L}{R}$ is known as the time constant and is defined as the interval after

which current or voltage changes 63.2% of its total change.

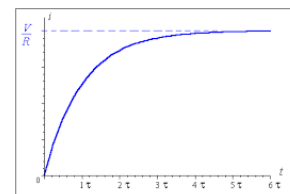

Let us analyse the transient condition of the R-L circuit as the circuit reaches steady state charging switch to S¹

$$L \frac{di^1(t)}{dt} + Ri^1(t) = 0$$

Solution of $i^1(t) = K^1 e^{(-R/L)t}$

Steady state current $i(0^+) = i(\infty) = \frac{V}{R}$

$$\frac{V}{R} = K^1 e^0$$

$$\Rightarrow K^1 = \frac{V}{R}$$

Therefore $i^1(t) = \frac{V}{R} e^{(-R/L)t}$, $V^1_R(t) = Ve^{(-R/L)t}$, $V^1_L(t) = L \frac{di^1(t)}{dt} = -Ve^{(-R/L)t}$

$i^1(t)$ and $V^1_R(t)$, $V^1_L(t)$ are plotted below.

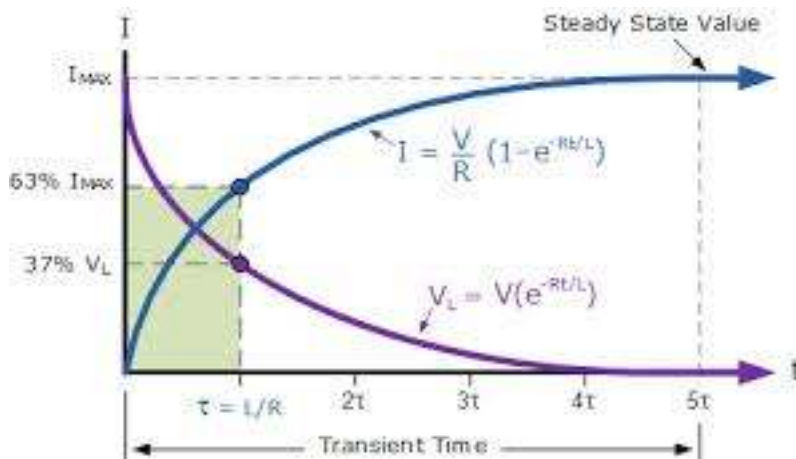

Transient response of series R-C circuit having DC excitation.

Consider a series R-C circuit as shown in figure. The switch S is closed at time $t=0$. Applying KVL

$$Ri(t) + \frac{1}{C} \int i(t) dt = V$$

Differentiating, we get

$$R \frac{di(t)}{dt} + \frac{1}{C} i(t) = 0$$

General solution of this differential equation is

$$i(t) = K e^{-t/RC}$$

at $t = 0^+$, $i(0^+) = \frac{V}{R}$ ∵ capacitor acts as a short-circuit at switching.

$$\frac{V}{R} = K e^0 \Rightarrow K = \frac{V}{R}$$

Therefore $i(t) = \frac{V}{R} e^{-t/RC}$

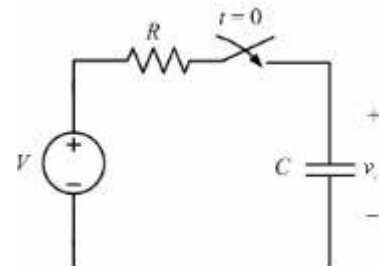

Voltage across the resistor and capacitor are

$$V_R(t) = i(t) \cdot R = V e^{-t/RC}$$

$$V_C(t) = - \int - \frac{V}{RC} e^{-t/RC} dt$$

$$= - (-RC) e^{-t/RC} = V(1 - e^{-t/RC})$$

At $t=0$, $i(t) = - \frac{V}{R}$, $V_C(t) = 0$, $V_R(t) = V$

At $t = \infty$, $i(t) = 0$, $V_C(t) = V$, $V_R(t) = 0$

At $t = RC$ $i(t) = - \frac{V}{R} e^{-1} = 0.368 \frac{V}{R}$,

$$V_i(t) = V(1 - e^{-1}) = 0.632V$$

Let us analyze another transient condition of R-C circuit as the circuit reaches at steady state (at $t=\infty$) by closing switch at point 2

$$Ri^1(t) + \frac{1}{C} \int i^1(t) dt = 0$$

Differentiating we get

$$R \frac{di^1(t)}{dt} + i^1(t) = 0$$

Its solution is $i^1(t) = K e^{-t/RC}$

However at $t=0^+$, capacitor keeps the steady state voltage $V_C(0^+) = V$ and direction of $i^1(t)$ during discharge is negative

$$i(0^+) = - \frac{V}{R}$$

$$- \frac{V}{R} = K e^0 \Rightarrow K = - \frac{V}{R}$$

$$i(t) = - \frac{V}{R} e^{-t/RC}$$

$$V_R^1(t) = i^1(t) \cdot R = -V e^{-t/RC}$$

$$V_C^1(t) = - \int i^1(t) dt = V e^{-t/RC}$$

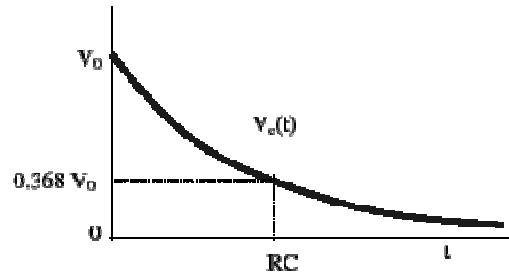

CHAPTER 6

LAPLACE TRANSFORM

The Laplace domain or the "Complex s Domain" is the domain into which the Laplace transform transforms a time-domain equation. s is a complex variable, composed of real and imaginary parts:

$$s = \sigma + j\omega$$

The Laplace domain graphs the real part (σ) as the horizontal axis, and the imaginary part (ω) as the vertical axis. The real and imaginary parts of s can be considered as independent quantities. The similarity of this notation with the notation used in Fourier transform theory is no coincidence; for $\sigma = 0$, the Laplace transform is the same as the Fourier transform if the signal is causal.

The mathematical definition of the Laplace transform is as follows:

$$F(s) = \mathcal{L}\{f(t)\} = \int_{0^-}^{\infty} e^{-st} f(t) dt$$

The transform, by virtue of the definite integral, removes all t from the resulting equation, leaving instead the new variable s, a complex number that is normally written as $s = \sigma + j\omega$. In essence, this transform takes the function f(t), and "transforms it" into a function in terms of s, F(s). As a general rule the transform of a function f(t) is written as F(s). Time-domain functions are written in lower-case, and the resultant s-domain functions are written in upper-case.

We will use the following notation to show the transform of a function:

$$f(t) \Leftrightarrow F(s)$$

We use this notation, because we can convert F(s) back into f(t) using the inverse Laplace transform.

The Inverse Transform

$$\mathcal{L}\{f'(t)\} = sF(s) - f(0)$$

Initial Value Theorem

$$f(0) \Leftrightarrow \lim_{s \rightarrow \infty} sF(s)$$

This is useful for finding the initial conditions of a function needed when we perform the transform of a differentiation operation.

Final Value Theorem

Similar to the Initial Value Theorem, the Final Value Theorem states that we can find the value of a function f , as t approaches infinity, in the laplace domain, as such:

$$\lim_{t \rightarrow \infty} f(t) \Leftrightarrow \lim_{s \rightarrow 0} sF(s)$$

This is useful for finding the steady state response of a circuit. The final value theorem may only be applied to stable systems.

Laplace Transformation of Signal Waveform

Laplace transform of unit step function is $\frac{1}{s}$

Laplace transform of ramp function is $\frac{1}{s^2}$

Laplace transform of unit impulse function is unity.

The laplace transform can be used independently on different circuit elements, and then the circuit can be solved entirely in the S Domain (Which is much easier). Let's take a look at some of the circuit elements:

Resistor

Resistors are time and frequency invariant. Therefore, the transform of a resistor is the same as the resistance of the resistor:

$$R(s) = r$$

Compare this result to the phasor impedance value for a resistance r :

$$Z_r = r \angle 0$$

You can see very quickly that resistance values are very similar between phasors and laplace transforms.

Ohm's Law

If we transform Ohm's law, we get the following equation:

$$V(s) = I(s)R$$

Now, following ohms law, the resistance of the circuit element is a ratio of the voltage to the current. So, we will solve for the quantity $\frac{V(s)}{I(s)}$, and the result will be the resistance of our circuit element.

$$R = \frac{V(s)}{I(s)}$$

This ratio, the input/output ratio of our resistor is an important quantity, and we will find this quantity for all of our circuit elements. We can say that the transform of a resistor with resistance r is given by:

$$\mathcal{L}\{\text{resistor}\} = R = r$$

Capacitors

Let us look at the relationship between voltage, current, and capacitance, in the time domain:

$$i(t) = C \frac{dv(t)}{dt}$$

Solving for voltage, we get the following integral:

$$v(t) = \frac{1}{C} \int_{t_0}^{\infty} i(t) dt$$

Then, transforming this equation into the laplace domain assuming the zero initial condition, we get the following:

$$V(s) = \frac{1}{C} \frac{1}{s} I(s)$$

Again, if we solve for the ratio $\frac{V(s)}{I(s)}$, we get the following:

$$\frac{V(s)}{I(s)} = \frac{1}{sC}$$

Therefore, the transform for a capacitor with capacitance C is given by:

$$\mathcal{L}\{\text{capacitor}\} = \frac{1}{sC}$$

Inductors

Let us look at our equation for inductance:

$$v(t) = L \frac{di(t)}{dt}$$

Putting this into the laplace domain assuming the zero initial condition, we get the formula:

$$V(s) = sLI(s)$$

And solving for our ratio $\frac{V(s)}{I(s)}$, we get the following:

$$\frac{V(s)}{I(s)} = sL$$

Therefore, the transform of an inductor with inductance L is given by:

$$\mathcal{L}\{Inductor\} = sL$$

Impedance

Impedance of all the load elements can be combined into a single format dependent on s , we call the effect of all load elements impedance, the same as we call it in phasor representation. We denote impedance values with a capital Z (but not a phasor \mathbf{Z}).

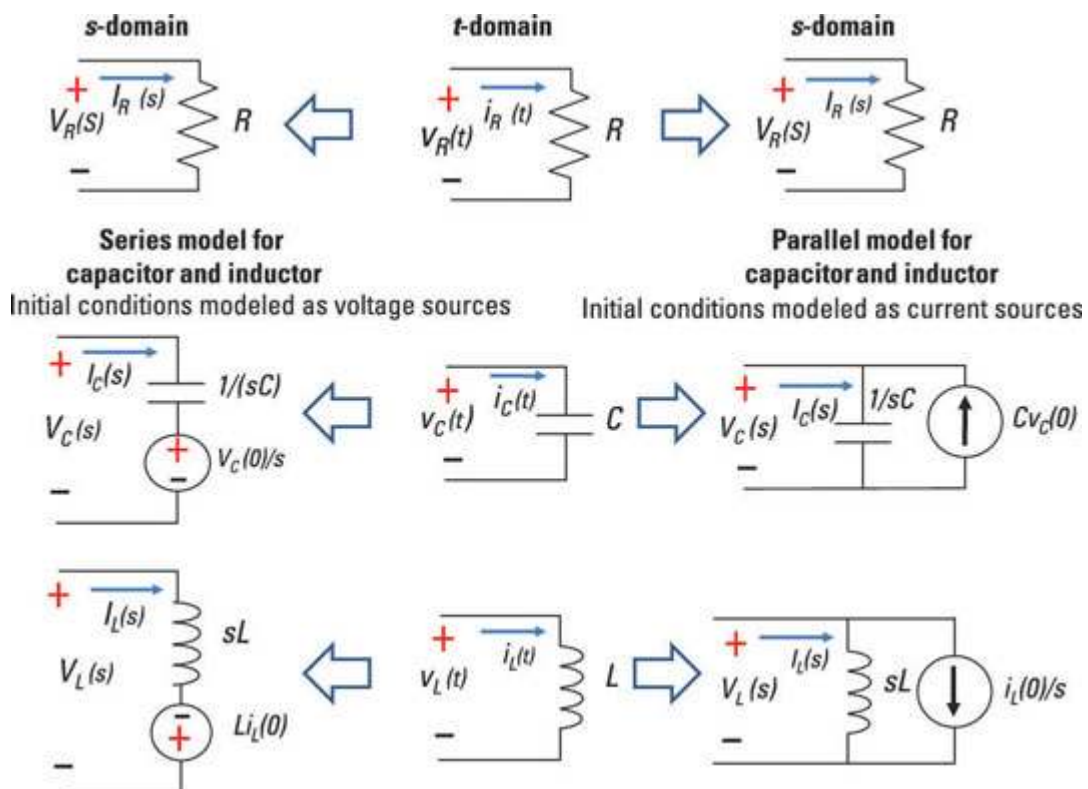

Determining electric current in circuits

In the network shown, determine the character of the currents $I_1(t)$, $I_2(t)$, and $I_3(t)$ assuming that each current is zero when the switch is closed.

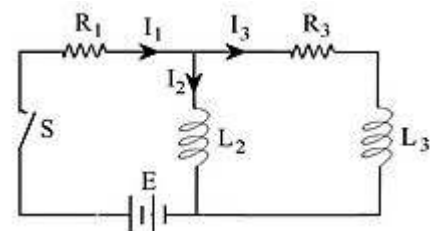

Solution:

Current flow at a joint in circuit

Since the algebraic sum of the currents at any junction is zero, then

$$I_1(t) - I_2(t) - I_3(t) = 0$$

Voltage balance on a circuit

Applying the voltage law to the circuit on the left we get

$$I_1(t)R_1 + L_2 \frac{dI_2(t)}{dt} = E(t)$$

Applying again the voltage law to the outside circuit, given that E is constant, we get

$$I_1(t)R_1 + I_3(t)R_3 + L_3 \frac{dI_3(t)}{dt} = E(t)$$

Laplace transforms of current and voltage equations

Transforming the above equations, we get

$$i_1(s) - i_2(s) - i_3(s) = 0$$

$$i_1(s)R_1 + sL_2i_2(s) = \frac{E'}{s}$$

$$i_1(s)R_1 + (R_3 + sL_3)i_3(s) = \frac{E'}{s}$$

The above three Laplace transformed equations show the benefits of integral transformation in converting differential equations into linear algebraic equations that could be solved for the dependent variables (the three currents in this case), then inverse transformed to yield the required solution

$$\text{Resistor: } V_R(s) = Ri_R(t) \rightarrow I_R(s) = \left(\frac{1}{R}\right)V_R(s)$$

$$\text{Capacitor: } V_c(s) = \frac{1}{sC}I_c(s) + \frac{v_c(0)}{s} \rightarrow I_c(s) = (sC)V_c(s) - Cv_c(0)$$

$$\text{Inductor: } V_L(s) = sLI_L(s) - Li_L(0) \rightarrow I_L(s) = \left(\frac{1}{sL}\right)V_L(s) + \frac{i_L(0)}{s}$$

Example: Find the capacitor voltage.

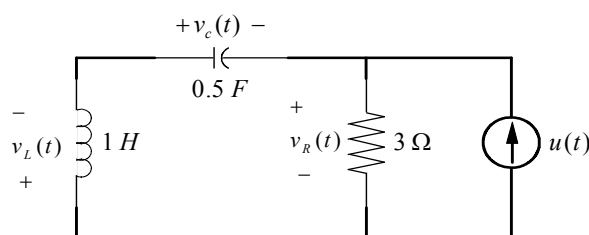

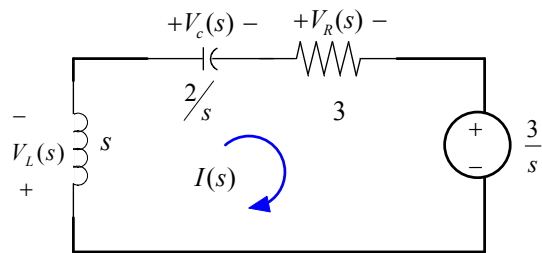
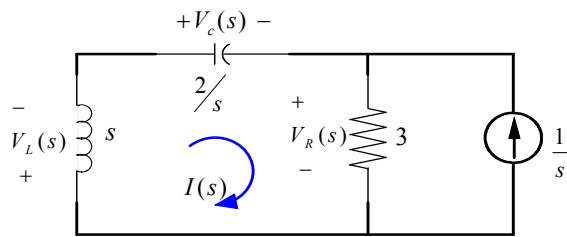

$$\left(s + \frac{2}{s} + 3 \right) I(s) + \frac{3}{s} = 0$$

$$\Rightarrow I(s) = \frac{-3}{s^2 + 3s + 2}$$

The capacitor's voltage

$$V_c(s) = \frac{2}{s} \cdot I(s) = \frac{-6}{s(s^2 + 3s + 2)}$$

Expanding $V_c(s)$ by partial fraction

$$V_c(s) = \frac{-6}{s(s+1)(s+2)} = \frac{K_1}{s} + \frac{K_2}{s+1} - \frac{K_3}{s+2}$$

$$v_c(t) = (-3 + 6e^{-t} - 3e^{-2t}) u(t)$$

Step response of an R-L circuit

Consider the RL circuit as shown in the figure assuming the initial current to be zero. At $t = 0$ the switch is closed and the voltage E is impressed on the circuit. The differential equation on application of KVL is

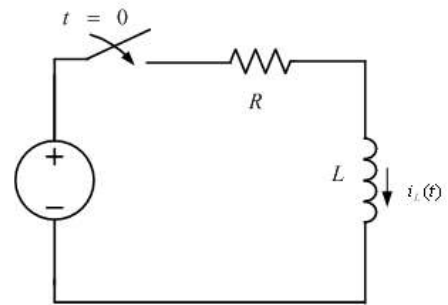

$$\begin{aligned}
 Ri(t) + L \frac{di(t)}{dt} &= E \\
 \Rightarrow RI(s) + L[sI(s) - i_L(0)] &= \frac{E}{s} \\
 \Rightarrow I(s)[sL + R] &= \frac{E}{s} \because i_L(0) = 0 \\
 \Rightarrow I(s) &= \frac{\frac{E}{s}}{sL + R} = \frac{\frac{E}{L}}{s\left(s + \frac{R}{L}\right)} = \frac{E}{R} \left[\frac{1}{s} - \frac{1}{s + \frac{R}{L}} \right] \\
 \text{taking inverse LT} \Rightarrow i(t) &= \frac{E}{R} \left[1 - e^{-\frac{R}{L}t} \right]
 \end{aligned}$$

Step response of an R-C circuit

Consider the R-C circuit as shown in the figure assuming the initial current to be zero. At $t = 0$ the switch is closed and the voltage E is impressed on the circuit. The differential equation on application of KVL is

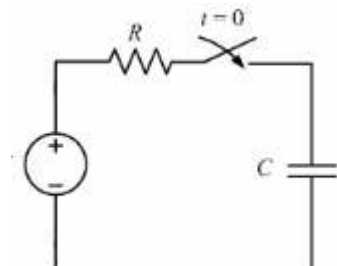

$$\begin{aligned}
 Ri(t) + \frac{1}{C} \int_0^t i(t) dt &= E \\
 \Rightarrow RI(s) + \frac{1}{C} \left[\frac{I(s)}{s} \right] &= \frac{E}{s} \\
 \Rightarrow I(s) \left[R + \frac{1}{Cs} \right] &= \frac{E}{s} \\
 \Rightarrow I(s) &= \frac{\frac{E}{s}}{s + \frac{1}{RC}} \\
 \text{taking inverse LT} i(t) &= \frac{E}{R} e^{-t \frac{1}{RC}}
 \end{aligned}$$

Step response of an R-L-C circuit

Consider the R-L-C series circuit as shown in the figure assuming the initial current to be zero. At $t = 0$ the switch is closed and the voltage E is impressed on the circuit. The differential equation on application of KVL is

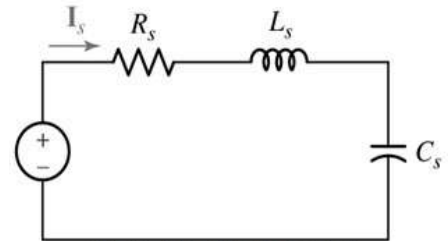

$$Ri(t) + L \frac{di(t)}{dt} + \frac{1}{C} \int_0^t i(t) dt = E$$

$$\Rightarrow RI(s) + L[sI(s)] + \frac{1}{C} \left[\frac{I(s)}{s} \right] = \frac{E}{s}$$

$$\Rightarrow I(s) = \frac{\frac{E}{s}}{sL + R + \frac{1}{Cs}} = \frac{\frac{E}{L}}{s^2 + \frac{R}{L}s + \frac{1}{LC}}$$

$$\Rightarrow I(s) = \frac{\frac{E}{L}}{(s-s_1)(s-s_2)} = \frac{K_1}{(s-s_1)} + \frac{K_2}{(s-s_2)}$$

$$\Rightarrow i(t) = K_1 e^{s_1 t} + K_2 e^{s_2 t}$$

Where s_1 & s_2 are the roots of the characteristic equation

$$s^2 + \frac{R}{L}s + \frac{1}{LC} \text{ and } K_1 \text{ \& } K_2 \text{ are constant.}$$

Value of s_1 & s_2 can be determined as

$$s_1, s_2 = -\frac{R}{2L} \pm \sqrt{\left(\frac{R}{2L}\right)^2 - \frac{1}{LC}}$$

Problem 1

In the network shown in the figure, the switch S is closed and a steady state is attained. At $t = 0$, the switch is opened. Determine the current through the inductor for $t > 0$.

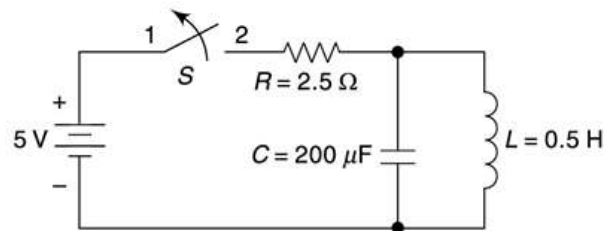

Solution

When the switch S is closed and the steady-state exists, the current through the inductor is,

$$i(0^-) = \frac{V}{R} = \frac{5}{2.5} = 2 \text{ A}$$

The voltage across the capacitor, $V_C(t) = 0$ as it is shorted.

For $t > 0$, the switch is opened. By KVL,

$$L \frac{di}{dt} + \frac{1}{C} \int_0^t i dt = 0$$

Taking Laplace transform,

$$L[sI(s) - i(0^-)] + \frac{I(s)}{Cs} = 0$$

$$\text{or } I(s) \left[sL + \frac{1}{Cs} \right] = Li(0^-)$$

Putting the values,

$$I(s) = 2 \frac{s}{s^2 + 10^4}$$

Taking inverse Laplace transform,

$$i(t) = 2 \cos 100t \quad (\text{A}); t \geq 0$$

Problem 2

A series R - L - C circuit with $R = 3\Omega$, $L = 1H$ and $C = 0.5 F$ is excited with a unit step voltage. Obtain an expression for the current, using Laplace transform. Assume that the circuit is relaxed initially.

Solution

By KVL,

$$RI(s) + sLI(s) - Li(0-) + \frac{1}{sC}I(s) + \frac{Q(0-)}{sC} = \frac{1}{s}$$

Since the circuit is initially relaxed,

$$\therefore i(0-) = 0 \quad \text{and} \quad Q(0-) = 0$$

Putting the values,

$$I(s) \left[3 + s + \frac{2}{s} \right] = \frac{1}{s}$$

$$\text{or } I(s) = \frac{1}{s^2 + 3s + 2} = \frac{1}{(s+1)(s+2)} = \frac{A_1}{s+1} + \frac{A_2}{s+2}$$

$$\text{where, } A_1 = \frac{1}{s+2} \Big|_{s=-1} = 1 \quad \text{and} \quad A_2 = \frac{1}{s+1} \Big|_{s=-2} = -1$$

$$\therefore I(s) = \frac{1}{s+1} - \frac{1}{s+2}$$

Taking inverse Laplace transform,

$$\begin{aligned} i(t) &= e^{-t} + e^{-2t} \text{ (A)} \\ &= 2e^{3t/2} \sinh\left(\frac{t}{2}\right) \text{ (A)} \end{aligned}$$

Problem 3

The circuit was in steady state with the switch in position 1. Find the current $i(t)$ for $t > 0$ if the switch is moved from position 1 to 2 at $t = 0$.

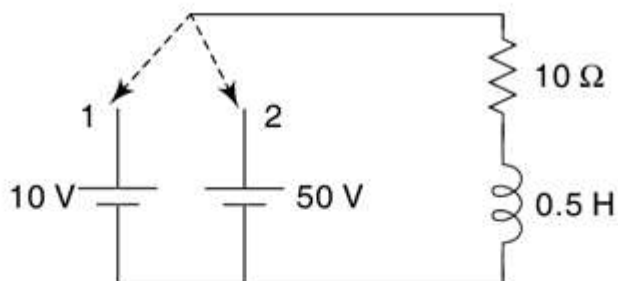

Solution

When the switch is in position 1, steady-state exists and the initial current through the inductor is,

$$i(0^-) = \frac{10}{10} = 1A$$

After the switch is moved to position 2, the KVL gives, in Laplace transform,

$$10I(s) + 0.5sI(s) - 0.5 \times 1 = \frac{50}{s}$$

$$\text{or, } I(s) = \frac{100}{s(s+20)} + \frac{1}{s+20} = 5 \left[\frac{1}{s} - \frac{1}{s+20} \right] + \frac{1}{s+20}$$

Taking inverse Laplace transform,

$$i(t) = 5 - 4e^{-20t} \quad (A); t > 0;$$

Problem 4

Find the response current of a series RL circuit consisting of a resistor $R = 3\Omega$ and an inductor $L = 1$ H when each of the following driving force voltage is applied:

- unit ramp voltage $r(t-2)$,
 - unit impulse voltage $\delta(t-2)$,
 - unit step voltage $u(t-2)$.
-

Solution

- Unit ramp voltage $r(t-2)$

Applying KVL to RL series circuit,

$$Ri + L \frac{di}{dt} = v(t) = r(t-2)$$

Taking Laplace transform,

$$(R + sL)I(s) = \frac{1}{s^2} e^{-2s}$$
$$I(s) = \frac{e^{-2s}}{s^2(sL + R)}$$

Substituting the values,

$$I(s) = \frac{e^{-2s}}{s^2(s+3)} = e^{-2s} \left[\frac{K_1}{s^2} + \frac{K_2}{s} + \frac{K_3}{s+3} \right]$$

$$\therefore K_1 = \left. \frac{1}{s+3} \right|_{s=0} = \frac{1}{3}$$

$\therefore K_2$

$$= \left. \frac{d}{ds} \left[\frac{1}{s+3} \right] \right|_{s=0} = \left. -\frac{1}{(s+3)^2} \right|_{s=0} = -\frac{1}{9}$$

$$\therefore K_3 = \left. \frac{1}{s^2} \right|_{s=-3} = \frac{1}{9}$$

$$\therefore I(s) = e^{-2s} \left[\frac{1/3}{s^2} + \frac{-1/9}{s} + \frac{1/9}{s+3} \right]$$

Taking inverse Laplace transform,

$$i(t) = -\frac{1}{9}u(t-2) + \frac{1}{3}r(t-2) + \frac{1}{9}e^{-3(t-2)}u(t-2) \quad \text{Ans.}$$

b. Unit impulse voltage $\delta(t-2)$:

In this case,

$$Ri + L \frac{di}{dt} = v(t) = \delta(t-2)$$

Taking Laplace transform,

$$(R + sL)I(s) = e^{-2s}$$
$$I(s) = \frac{e^{-2s}}{(sL + R)} = \frac{e^{-2s}}{(s + 3)}$$

Taking inverse Laplace transform,

$$i(t) = e^{-3(t-2)}u(t-2) \quad \text{Ans.}$$

c. Unit step voltage $u(t-2)$

In this case,

$$Ri + L \frac{di}{dt} = v(t) = u(t-2)$$

Taking Laplace transform,

$$(R + sL)I(s) = \frac{e^{-2s}}{s}$$
$$I(s) = \frac{e^{-2s}}{(sL + R)} = \frac{e^{-2s}}{s(s + 3)} = \frac{1}{3}e^{-2s} \left[\frac{1}{s} - \frac{1}{(s + 3)} \right]$$

Taking inverse Laplace transform,

$$i(t) = \frac{1}{3}u(t-2) - \frac{1}{3}e^{-3(t-2)}u(t-2) \quad \text{Ans.}$$



CHAPTER 7

TWO-PORT NETWORKS

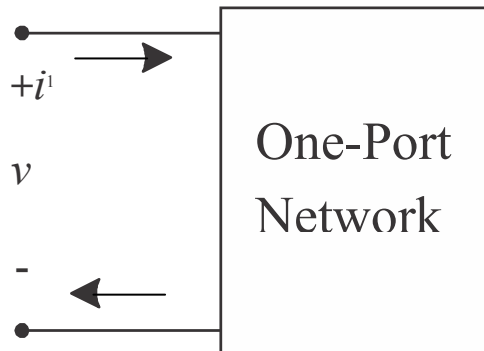

- a) A pair of terminals at which a signal (voltage or current) may enter or leave is called a port.
- b) A network having only one such pair of terminals is called a one-port network.
- c) No connections may be made to any other nodes internal to the network.
- d) By KCL, we therefore have $i_1 = i_1'$

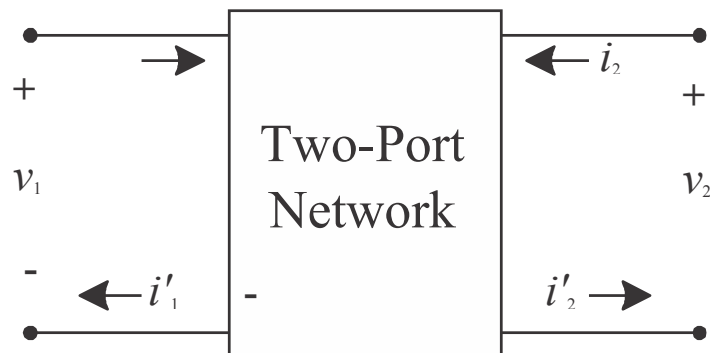

- Two-port networks are used to describe the relationship between a pair of terminals
- The analysis methods we will discuss require the following conditions be met
 1. Linearity
 2. No independent sources inside the network
 3. No stored energy inside the network (zero initial conditions)
 4. $i_1 = i_1'$ and $i_2 = i_2'$

Impedance Parameters

- Suppose the currents and voltages can be measured.
- Alternatively, if the circuit in the box is known, V_1 and V_2 can be calculated based on circuit analysis.
- Relationship can be written in terms of the impedance parameters.
- We can also calculate the impedance parameters after making two sets of measurements.

$$V_1 = z_{11}I_1 + z_{12}I_2$$

$$V_2 = z_{21}I_1 + z_{22}I_2$$

If the right port is an open circuit ($I_2=0$), then we can easily solve for two of the impedance parameters: Similarly by open circuiting left hand port ($I_1=0$) we can solve for the other two parameters.

$$Z_{11} = \text{input impedance} = \frac{V_1}{I_1} \Big|_{I_2=0} \quad Z_{21} = \text{forward transfer impedance} = \frac{V_2}{I_1} \Big|_{I_2=0}$$

$$Z_{12} = \text{reverse transfer impedance} = \frac{V_1}{I_2} \Big|_{I_1=0} \quad Z_{22} = \text{output impedance} = \frac{V_2}{I_2} \Big|_{I_1=0}$$

Impedance Parameter Equivalent

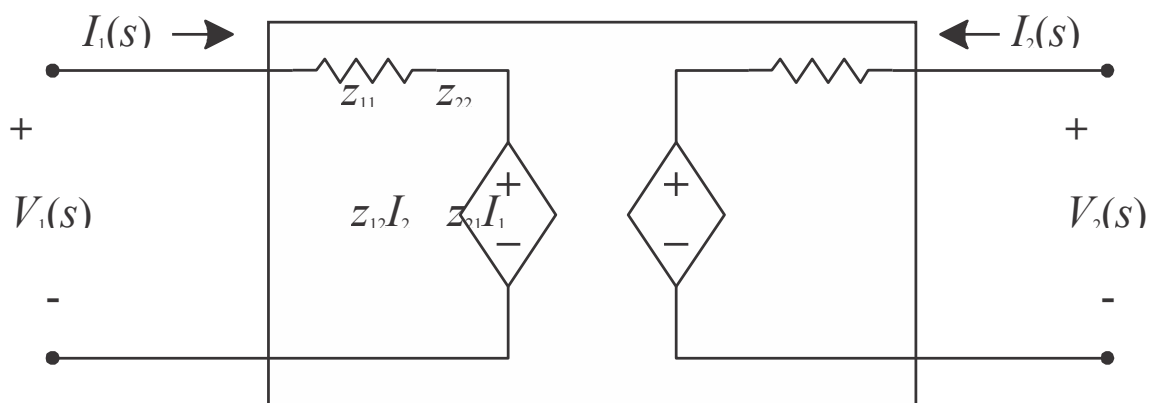

$$V_1 = z_{11}I_1 + z_{12}I_2$$

$$V_2 = z_{21}I_1 + z_{22}I_2$$

- Once we know what the impedance parameters are, we can model the behavior of the two-port with an equivalent circuit.
- Notice the similarity to Thévenin and Norton equivalents

Admittance Parameters

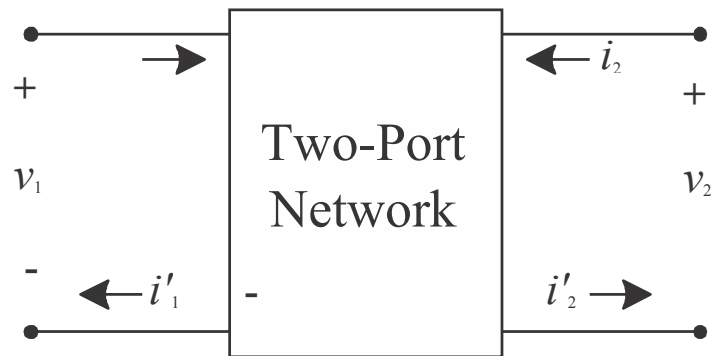

$$I_1 = y_{11}V_1 + y_{12}V_2$$

$$I_2 = y_{21}V_1 + y_{22}V_2$$

$$Y_{11} = \text{input admittance} = \frac{I_1}{V_1} \Big|_{V_2 = 0}$$

$$Y_{21} = \text{forward transfer admittance} = \frac{I_2}{V_1} \Big|_{V_2 = 0}$$

$$Y_{22} = \text{output admittance} = \frac{I_2}{V_2} \Big|_{V_1 = 0}$$

$$Y_{12} = \text{reverse transfer admittance} = \frac{I_1}{V_2} \Big|_{V_1 = 0}$$

Hybrid Parameters

$$V_1 = h_{11}I_1 + h_{12}V_2$$

$$I_2 = h_{21}I_1 + h_{22}V_2$$

$$h_{11} = \text{input impedance} = \frac{V_1}{I_1} \Big|_{V_2 = 0}$$

$$h_{21} = \text{forward current ratio} = \frac{I_2}{I_1} \Big|_{V_2 = 0}$$

$$h_{12} = \text{reverse voltage ratio} = \frac{V_1}{V_2} \Big|_{I_1 = 0}$$

$$h_{22} = \text{output admittance} = \frac{I_2}{V_2} \Big|_{I_1 = 0}$$

Example:

Given the following circuit. Determine the Z parameters.

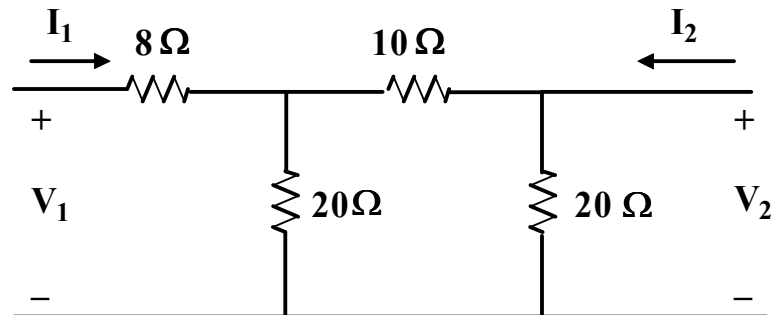

$$Z_{11} = 8 + 20 \parallel 30 = 20 \Omega$$

$$Z_{22} = 20 \parallel 30 = 12 \Omega$$

$$Z_{12} = \frac{V_1}{I_2} \Big|_{I_1=0} = 0$$

$$V_1 = \frac{20 \times I_2 \times 20}{20 + 30} = 8xI_2 \quad \text{Therefore } z_{12} = \frac{8xI_2}{I_2} = 8 \Omega = z_{21}$$

The Z parameter equations can be expressed in matrix form as follows.

$$\begin{bmatrix} V_1 \\ V_2 \end{bmatrix} = \begin{bmatrix} z_{11} & z_{12} \\ z_{21} & z_{22} \end{bmatrix} \begin{bmatrix} I_1 \\ I_2 \end{bmatrix}$$

$$\begin{bmatrix} V_1 \\ V_2 \end{bmatrix} = \begin{bmatrix} 20 & 8 \\ 8 & 12 \end{bmatrix} \begin{bmatrix} I_1 \\ I_2 \end{bmatrix}$$

Example:

Given the following circuit. Determine the Y parameters.

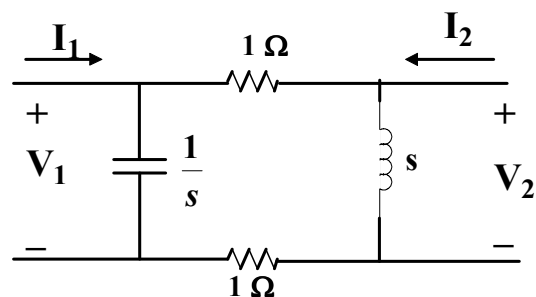

$$I_1 = y_{11} V_1 + y_{12} V_2$$

$$I_2 = y_{21} V_1 + y_{22} V_2$$

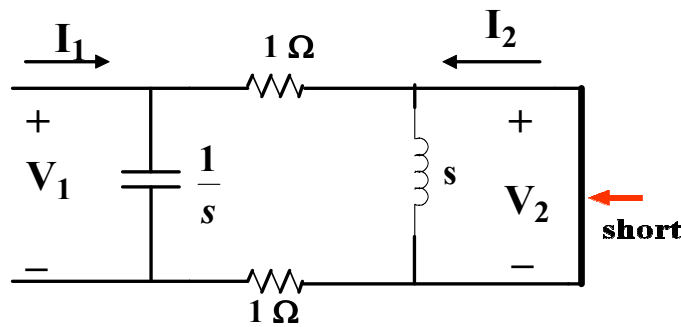

To find y_{11}

$$V_1 = I_1 \left(\frac{2/s}{2 + 1/s} \right) = I_1 \left[\frac{2}{2s + 1} \right]$$

$$\text{So } y_{11} = \frac{I_1}{V_1} \Big|_{V_2=0} = \frac{I_1}{V_1} \Big|_{V_2=0} = s + 0.5$$

To find y_{12} and y_{21} we reverse things and short V_1

$$y_{21} = \frac{I_2}{V_1} \Big|_{V_2=0}$$

$$V_1 = -2I_2$$

$$y_{21} = \frac{I_2}{V_1} = 0.5 \text{ S}$$

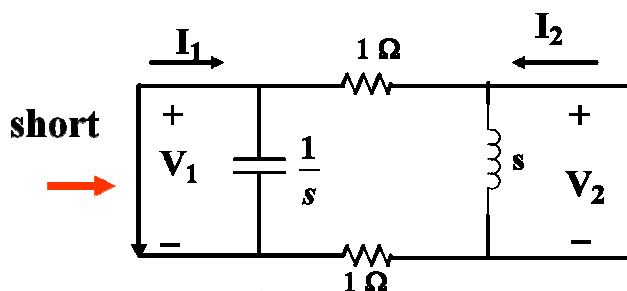

$$y_{12} = \frac{I_1}{V_2} \Big|_{V_1=0}$$

$$V_2 = -2I_1 \quad y_{12} = \frac{I_1}{V_2} = 0.5s$$

$$y_{22} = 0.5 + \frac{1}{s}$$

$$y_{22} = \frac{I_2}{V_2} \Big|_{V_1=0} \quad V_2 = I_2 \frac{2s}{(s+2)} \quad y_{22} = 0.5 + \frac{1}{s}$$

Problem 1

Find the Z and Y parameter for the networks shown in figure.

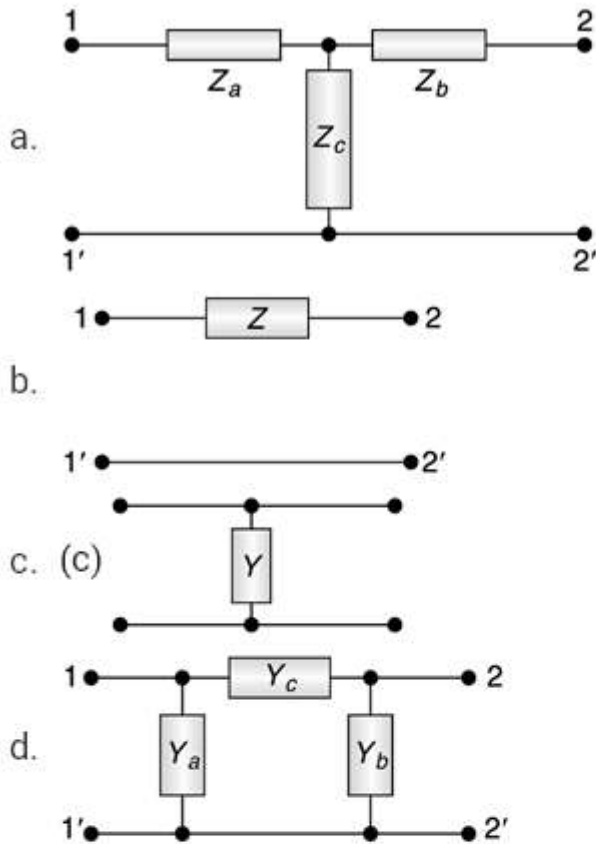

Solution

a. By KVL, $(Z_a + Z_c)I_1 + Z_c I_2 = V_1$

and $Z_c I_1 + (Z_b + Z_c)I_2 = V_2$

Thus, the Z-parameters are:

$$z_{11} = (Z_a + Z_c), z_{12} = z_{21} = Z_c, z_{22} = (Z_b + Z_c)$$

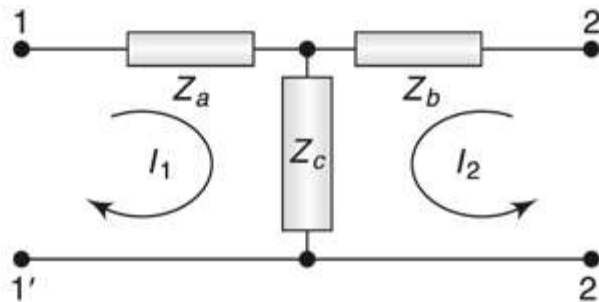

b. By KCL,

$$I_1 = \frac{V_1 - V_2}{Z} = \frac{1}{Z}V_1 - \frac{1}{Z}V_2$$

$$\text{and } I_2 = \frac{V_2 - V_1}{Z} = -\frac{1}{Z}V_1 + \frac{1}{Z}V_2$$

Thus, the y-parameters are,

$$y_{11} = \frac{1}{Z} = y_{22} \quad y_{12} = y_{21} = -\frac{1}{Z}$$

Since, $\Delta y = y_{11}y_{22} - y_{12}y_{21} = 0$, the z-parameters do not exist for this network.



c. By KVL,

$$V_1 =$$

$$\frac{I_1 + I_2}{Y} = V_2 \quad \text{or, } V_1 = \left(\frac{1}{Y}\right)I_1 + \left(\frac{1}{Y}\right)I_2 \quad \text{and } V_2 = \left(\frac{1}{Y}\right)I_1 + \left(\frac{1}{Y}\right)I_2$$

Thus, the z-parameters are,

$$z_{11} = z_{22} = \frac{1}{Y} = z_{12} = z_{21}$$

Since, $\Delta z = z_{11}z_{22} - z_{12}z_{21} = 0$, the y-parameters do not exist for this network.

d. By KCL,

$$I_1 = Y_a V_1 + (V_1 - V_2)Y_c = V_1(Y_a + Y_c) - V_2 Y_c$$

$$I_2 = Y_b V_2 + (V_2 - V_1)Y_c = -V_1 Y_c + V_2(Y_b + Y_c)$$

Thus, the y-parameters are:

$$y_{11} = Y_a + Y_c; \quad y_{12} = y_{21} = -Y_c; \quad y_{22} = Y_b + Y_c$$

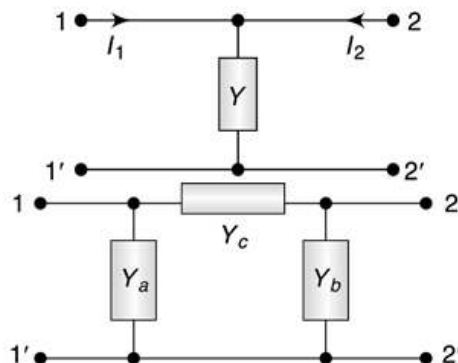

Problem 2

- a. The following equations give the voltages V_1 and V_2 at the two ports of a two port network, $V_1 = 5I_1 + 2I_2$, $V_2 = 2I_1 + I_2$;
A load resistance of 3Ω is connected across port-2. Calculate the input impedance.
- b. The z-parameters of a two port network are $z_{11} = 5 \Omega$, $z_{22} = 2 \Omega$, $z_{12} = z_{21} = 3 \Omega$. Load resistance of 4Ω is connected across the output port. Calculate the input impedance.
-

Solution

- a. From the given equations,

$$V_1 = 5I_1 + 2I_2 \quad (\text{i})$$

$$V_2 = 2I_1 + I_2 \quad (\text{ii})$$

$$\text{At the output, } V_2 = -I_2 R_L = -3I_2$$

Putting this value in (ii),

$$-3I_2 = 2I_1 + I_2 \text{ fi } I_2 = -I_1/2$$

$$\text{Putting in (i), } V_1 = 5I_1 + \left(\frac{-I_1}{2} \right) = 4I_1$$

$$\therefore \text{ Input impedance, } Z_{\text{in}} = \frac{V_1}{I_1} = 4\Omega$$

b. [Same as Prob. (a)] $Z_{\text{in}} = \frac{V_1}{I_1} = 3.5\Omega$

Problem 3

Determine the h -parameter with the following data:

- with the output terminals short circuited, $V_1 = 25 \text{ V}$, $I_1 = 1 \text{ A}$, $I_2 = 2 \text{ A}$
- with the input terminals open circuited, $V_1 = 10 \text{ V}$, $V_2 = 50 \text{ V}$, $I_2 = 2 \text{ A}$

Solution

The h -parameter equations are,

$$V_1 = h_{11}I_1 + h_{12}V_2$$

$$I_2 = h_{21}I_1 + h_{22}V_2$$

- a. With output short-circuited, $V_2 = 0$, given: $V_1 = 25 \text{ V}$, $I_1 = 1 \text{ A}$ and $I_2 = 2 \text{ A}$.

$$\therefore \left. \begin{array}{l} 25 = h_{11} \times 1 \\ \text{and} \quad 2 = h_{21} \times 1 \end{array} \right\} \Rightarrow h_{11} = 25 \Omega, \text{ and } h_{21} = 2$$

- b. With input open-circuited, $I_1 = 0$, given: $V_1 = 10 \text{ V}$, $V_2 = 50 \text{ V}$ and $I_2 = 2 \text{ A}$.

$$\therefore \left. \begin{array}{l} 10 = h_{12} \times 50 \\ \text{and} \quad 2 = h_{22} \times 50 \end{array} \right\} \Rightarrow h_{12} = \frac{1}{5} = 0.2 \text{ and } h_{22} = \frac{1}{25} \text{ } \mathcal{U} = 0.04 \text{ } \mathcal{U}$$

Thus, the h -parameters are:

$$[h] = \begin{bmatrix} 25 \Omega & 0.2 \\ 2 & 0.04 \Omega^{-1} \end{bmatrix}$$

Problem 4

- Find the equivalent π -network for the T -network shown in the Fig. (a).
- Find the equivalent T -network for the π -network shown in the Fig. (b).

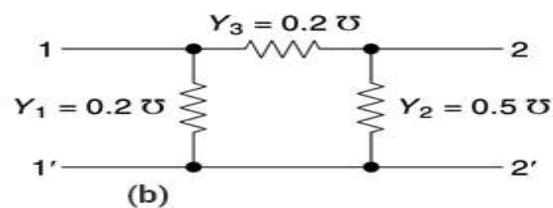
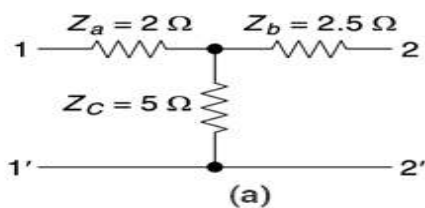

Solution

- Let the equivalent π -network have Y_C as the series admittance and Y_A and Y_B as the shunt admittances at port-1 and port-2, respectively.

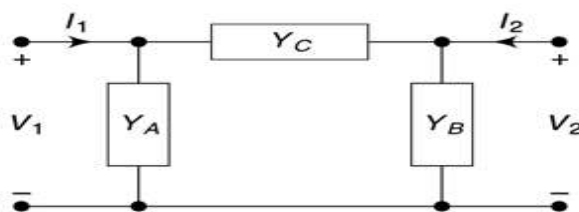

Now, the z-parameters are given as:

$$z_{11} = (Z_A + Z_C) = 7 \Omega, z_{12} = z_{21} = Z_C = 5 \Omega, z_{22} = (Z_B + Z_C) = 7.5 \Omega$$

$$\therefore \Delta z = (7 \times 7.5 - 5 \times 5) = 27.5 \Omega^2$$

$$\therefore y_{11} = \frac{z_{22}}{\Delta z} = \frac{7.5}{27.5} \text{ S}$$

$$y_{12} = y_{21} = -\frac{z_C}{\Delta z} = -\frac{5}{27.5} \text{ S}$$

$$y_{22} = \frac{z_{11}}{\Delta z} = \frac{7}{27.5} \text{ S}$$

$$\therefore Y_A = (y_{11} + y_{12}) = \frac{2.5}{27.5} = \frac{1}{11} \text{ S}$$

$$\therefore Y_B = (y_{22} + y_{12}) = \frac{2}{27.5} \text{ S}$$

$$\text{and } Y_C = -y_{21} = \frac{5}{27.5} = \frac{2}{11} \text{ S}$$

Thus, the impedances of the equivalent π -networks are:

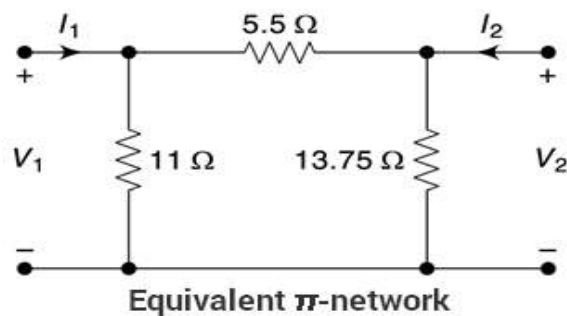

$$\left. \begin{aligned} Z_A &= \frac{1}{Y_A} = 11 \Omega, \\ Z_B &= \frac{1}{Y_B} = 13.75 \Omega, \\ Z_C &= \frac{1}{Y_C} = 5.5 \Omega \end{aligned} \right\}$$

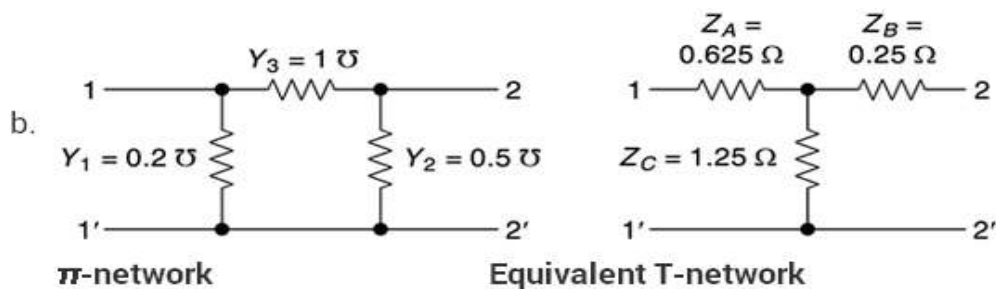

The y -parameters,

$$y_{11} = 1.2 \text{ S}, y_{12} = y_{21} = -1 \text{ S}, \text{ and } y_{22} = 1.5 \text{ S}$$

$$\therefore \Delta y = (1.2 \times 1.5 - 1) = 0.8$$

$$\therefore z_{11} = \frac{y_{22}}{\Delta y} = \frac{1.5}{0.8} \Omega, z_{12} = z_{21} = -\frac{y_{12}}{\Delta y} = \frac{1}{0.8} \Omega, z_{22} = \frac{y_{11}}{\Delta y} = \frac{1.2}{0.8} \Omega$$

$$\left. \begin{aligned} Z_A &= (z_{11} - z_{12}) = \frac{0.5}{0.8} = 0.625 \Omega \\ \therefore Z_B &= (z_{22} - z_{12}) = \frac{0.2}{0.8} = 0.25 \Omega \\ Z_C &= z_{12} = \frac{1}{0.8} = 1.25 \Omega \end{aligned} \right\}$$



CHAPTER 8

LOW PASS FILTER INTRODUCTION

Basically, an electrical filter is a circuit that can be designed to modify, reshape or reject all unwanted frequencies of an electrical signal and accept or pass only those signals wanted by the circuit's designer. In other words they "filter-out" unwanted signals and an ideal filter will separate and pass sinusoidal input signals based upon their frequency.

In low frequency applications (up to 100kHz), passive filters are generally constructed using simple RC(Resistor-Capacitor) networks, while higher frequency filters (above 100kHz) are usually made from RLC (Resistor-Inductor-Capacitor) components.

Passive Filters are made up of passive components such as resistors, capacitors and inductors and have no amplifying elements (transistors, op-amps, etc) so have no signal gain, therefore their output level is always less than the input.

Filters are so named according to the frequency range of signals that they allow to pass through them, while blocking or "attenuating" the rest. The most commonly used filter designs are the:

- 1. The Low Pass Filter – the low pass filter only allows low frequency signals from 0Hz to its cut-off frequency, f_c point to pass while blocking those any higher.
- 2. The High Pass Filter – the high pass filter only allows high frequency signals from its cut-off frequency, f_c point and higher to infinity to pass through while blocking those any lower.
- 3. The Band Pass Filter – the band pass filter allows signals falling within a certain frequency band setup between two points to pass through while blocking both the lower and higher frequencies either side of this frequency band.
- 4 Band Stop Filter - It is so called *band-elimination*, *band-reject*, or *notch* filters; this kind of filter passes all frequencies above and below a particular range set by the component values.

Simple First-order passive filters (1st order) can be made by connecting together a single resistor and a single capacitor in series across an input signal, (V_{in}) with the output of the filter, (V_{out}) taken from the junction of these two components. Depending on which way around we connect the resistor and the capacitor with regards to the output signal determines the type of filter construction resulting in either a Low Pass Filter or a High Pass Filter.

As the function of any filter is to allow signals of a given band of frequencies to pass unaltered while attenuating or weakening all others those are not

wanted, we can define the amplitude response characteristics of an ideal filter by using an ideal frequency response curve of the four basic filter types as shown.

IDEAL FILTER RESPONSE CURVES

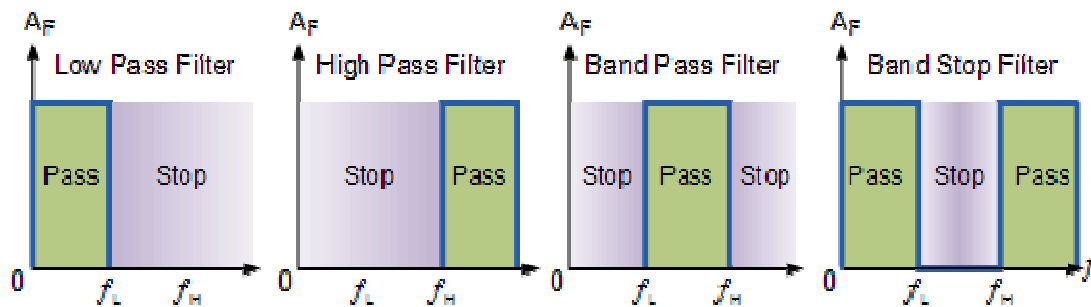

A Low Pass Filter can be a combination of capacitance, inductance or resistance intended to produce high attenuation above a specified frequency and little or no attenuation below that frequency. The frequency at which the transition occurs is called the “cutoff” frequency. The simplest low pass filters consist of a resistor and capacitor but more sophisticated low pass filters have a combination of series inductors and parallel capacitors. In this tutorial we will look at the simplest type, a passive two component RC low pass filter.

THE LOW PASS FILTER

A simple passive RC Low Pass Filter or LPF, can be easily made by connecting together in series a single Resistor with a single Capacitor as shown below. In this type of filter arrangement the input signal (V_{in}) is applied to the series combination (both the Resistor and Capacitor together) but the output signal (V_{out}) is taken across the capacitor only. This type of filter is known generally as a “first-order filter” or “one-pole filter”, why first-order or single-pole?, because it has only “one” reactive component, the capacitor, in the circuit.

RC LOW PASS FILTER CIRCUIT

As mentioned previously in the Capacitive Reactance tutorial, the reactance of a capacitor varies inversely with frequency, while the value of the resistor remains constant as the frequency changes. At low frequencies the capacitive reactance, (X_c) of the capacitor will be very large compared to the resistive value of the resistor, R and as a result the voltage across the capacitor, V_c will also be large while the voltage drop across the resistor, V_r will be much lower. At high frequencies the reverse is true with V_c being small and V_r being large.

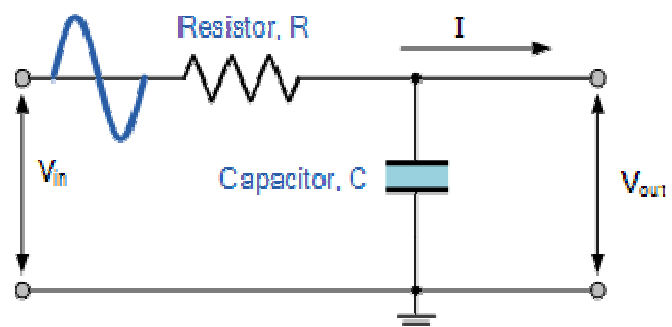

While the circuit above is that of an RC Low Pass Filter circuit, it can also be classed as a frequency variable potential divider circuit similar to the one we looked

at in the Resistors tutorial. In that tutorial we used the following equation to calculate the output voltage for two single resistors connected in series.

$$V_{\text{out}} = V_{\text{in}} \times \frac{R_2}{R_1 + R_2}$$

where: $R_1 + R_2 = R_T$, the total resistance of the circuit

We also know that the capacitive reactance of a capacitor in an AC circuit is given as:

$$X_C = \frac{1}{2\pi f C} \text{ in Ohm's}$$

Opposition to current flow in an AC circuit is called **impedance**, symbol Z and for a series circuit consisting of a single resistor in series with a single capacitor, the circuit impedance is calculated as:

$$Z = \sqrt{R^2 + X_C^2}$$

Then by substituting our equation for impedance above into the resistive potential divider equation gives us:

RC POTENTIAL DIVIDER EQUATION

$$V_{\text{out}} = V_{\text{in}} \times \frac{X_C}{\sqrt{R^2 + X_C^2}} = V_{\text{in}} \frac{X_C}{Z}$$

So, by using the potential divider equation of two resistors in series and substituting for impedance we can calculate the output voltage of an **RC Filter** for any given frequency.

LOW PASS FILTER EXAMPLE

A Low Pass Filter circuit consisting of a resistor of $4k7\Omega$ in series with a capacitor of $47nF$ is connected across a $10v$ sinusoidal supply. Calculate the output voltage (V_{out}) at a frequency of $100Hz$ and again at frequency of $10,000Hz$ or $10kHz$.

Voltage Output at a Frequency of 100Hz.

$$X_c = \frac{1}{2\pi f C} = \frac{1}{2\pi \times 100 \times 47 \times 10^{-9}} = 33,863\Omega$$

$$V_{OUT} = V_{IN} \times \frac{X_c}{\sqrt{R^2 + X_c^2}} = 10 \times \frac{33863}{\sqrt{4700^2 + 33863^2}} = 9.9v$$

Voltage Output at a Frequency of 10,000Hz (10kHz).

$$X_c = \frac{1}{2\pi f C} = \frac{1}{2\pi \times 10,000 \times 47 \times 10^{-9}} = 338.6\Omega$$

$$V_{OUT} = V_{IN} \times \frac{X_c}{\sqrt{R^2 + X_c^2}} = 10 \times \frac{338.6}{\sqrt{4700^2 + 338.6^2}} = 0.718v$$

FREQUENCY RESPONSE

We can see from the results above that as the frequency applied to the RC network increases from $100Hz$ to $10kHz$, the voltage dropped across the capacitor and therefore the output voltage (V_{out}) from the circuit decreases from $9.9v$ to $0.718v$.

By plotting the networks output voltage against different values of input frequency, the Frequency Response Curve or Bode Plot function of the low pass filter circuit can be found, as shown below.

Frequency Response of a 1st-order Low Pass Filter

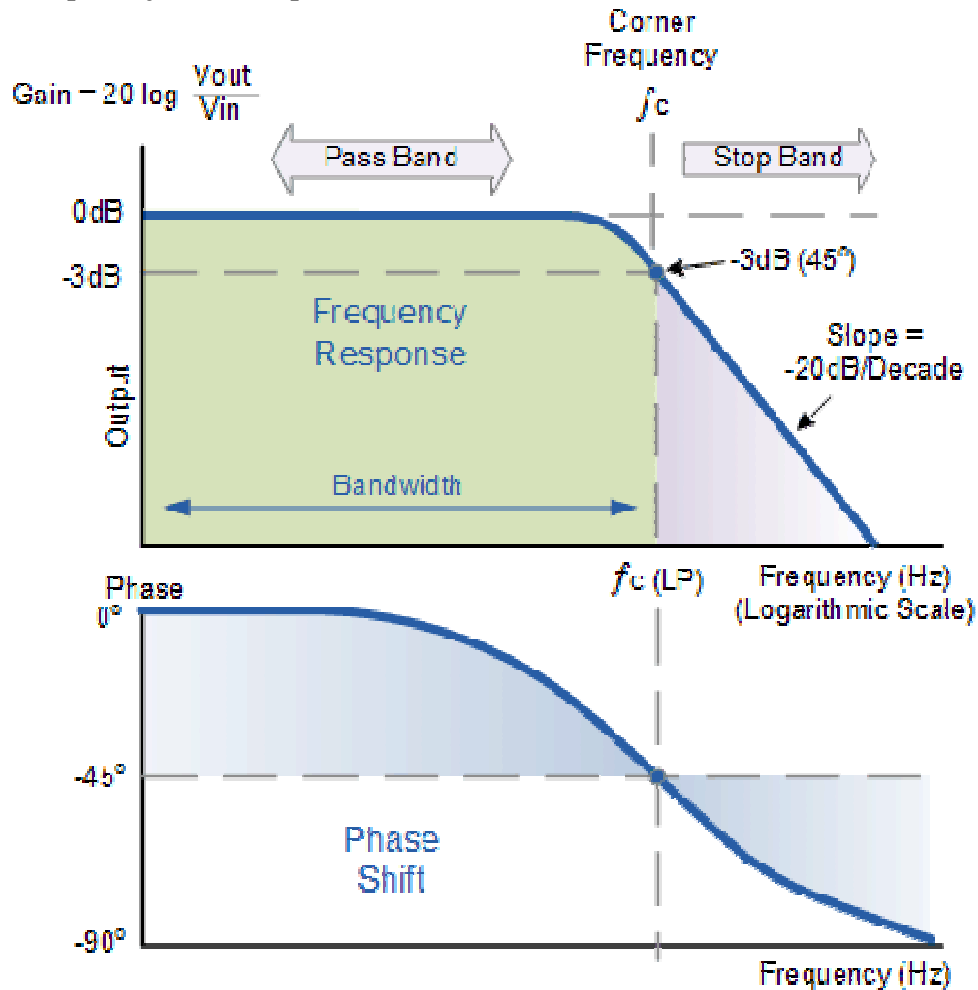

The Bode Plot shows the Frequency Response of the filter to be nearly flat for low frequencies and the entire input signal is passed directly to the output, resulting in a gain of nearly 1, called unity, until it reaches its Cut-off Frequency point (f_c). This is because the reactance of the capacitor is high at low frequencies and blocks any current flow through the capacitor.

After this cut-off frequency point the response of the circuit decreases to zero at a slope of -20dB/ Decade or (-6dB/Octave) “roll-off”. Note that the angle of the slope, this -20dB/ Decade roll-off will always be the same for any RC combination.

Any high frequency signals applied to the low pass filter circuit above this cut-off frequency point will become greatly attenuated, that is they rapidly decrease. This happens because at very high frequencies the reactance of the capacitor becomes so low that it gives the effect of a short circuit condition on the output terminals resulting in zero output.

Then by carefully selecting the correct resistor-capacitor combination, we can create a RC circuit that allows a range of frequencies below a certain value to pass through the circuit unaffected while any frequencies applied to the circuit above this cut-off point to be attenuated, creating what is commonly called a **Low Pass Filter**.

For this type of “Low Pass Filter” circuit, all the frequencies below this cut-off, f_c point that are unaltered with little or no attenuation and are said to be in the filter's Pass band zone. This pass band zone also represents the Bandwidth of the filter. Any signal frequencies above this point cut-off point are generally said to be in the filter's Stop band zone and they will be greatly attenuated.

This “Cut-off”, “Corner” or “Breakpoint” frequency is defined as being the frequency point where the capacitive reactance and resistance are equal, $R = X_c = 4k7\Omega$. When this occurs the output signal is attenuated to 70.7% of the input signal value or -3dB ($20 \log (V_{out}/V_{in})$) of the input. Although $R = X_c$, the output is not half of the input signal. This is because it is equal to the vector sum of the two and is therefore 0.707 of the input.

As the filter contains a capacitor, the Phase Angle (Φ) of the output signal LAGS behind that of the input and at the -3dB cut-off frequency (f_c) and is -45° out of phase. This is due to the time taken to charge the plates of the capacitor as the input voltage changes, resulting in the output voltage (the voltage across the capacitor) “lagging” behind that of the input signal. The higher the input frequency applied to the filter the more the capacitor lags and the circuit becomes more and more “out of phase”.

The cut-off frequency point and phase shift angle can be found by using the following equation:

CUT-OFF FREQUENCY AND PHASE SHIFT

$$f_c = \frac{1}{2\pi RC} = \frac{1}{2\pi \times 4700 \times 47 \times 10^{-9}} = 720\text{Hz}$$

$$\text{Phase Shift } \phi = -\arctan(2\pi fRC)$$

Then for our simple example of a “Low Pass Filter” circuit above, the cut-off frequency (f_c) is given as 720Hz with an output voltage of 70.7% of the input voltage value and a phase shift angle of -45°.

HIGH PASS FILTERS

A High Pass Filter or HPF, is the exact opposite to that of the previously seen Low Pass filter circuit, as now the two components have been interchanged with the output signal (V_{out}) being taken from across the resistor as shown.

Where as the low pass filter only allowed signals to pass below its cut-off frequency point, f_c , the passive high pass filter circuit as its name implies, only passes signals above the selected cut-off point, f_c eliminating any low frequency signals from the waveform. Consider the circuit below.

THE HIGH PASS FILTER CIRCUIT

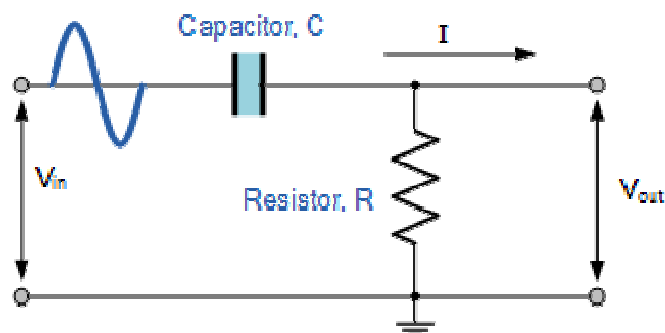

In this circuit arrangement, the reactance of the capacitor is very high at low frequencies so the capacitor acts like an open circuit and blocks any input signals at V_{in} until the cut-off frequency point (f_c) is reached. Above this cut-off frequency point the reactance of the capacitor has reduced sufficiently as to now act more like a short circuit allowing the entire input signal to pass directly to the output as shown below in the High Pass Frequency Response Curve.

FREQUENCY RESPONSE OF A 1ST ORDER HIGH PASS FILTER.

$$\text{Gain (dB)} = 20 \log \frac{V_{out}}{V_{in}}$$

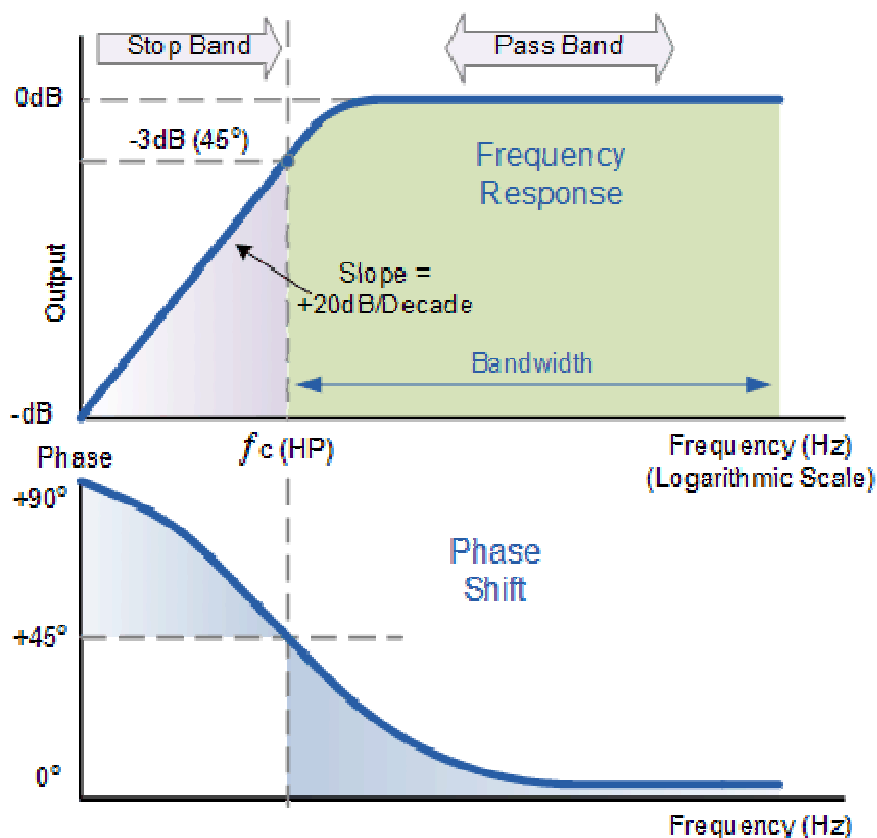

The Bode Plot or Frequency Response Curve above for a High Pass filter is the exact opposite to that of a low pass filter. Here the signal is attenuated or damped at low frequencies with the output increasing at +20dB/Decade (6dB/Octave) until the frequency reaches the cut-off point (f_c) where again $R = X_c$. It has a response curve that extends down from infinity to the cut-off frequency, where the output voltage amplitude is $1/\sqrt{2} = 70.7\%$ of the input signal value or -3dB ($20 \log (V_{out}/V_{in})$) of the input value.

Also we can see that the phase angle (Φ) of the output signal LEADS that of the input and is equal to +45° at frequency f_c . The frequency response curve for a high pass filter implies that the filter can pass all signals out to infinity. However in practice, the high pass filter response does not extend to infinity but is limited by the electrical characteristics of the components used.

The cut-off frequency point for a first order high pass filter can be found using the same equation as that of the low pass filter, but the equation for the phase shift is modified slightly to account for the positive phase angle as shown below.

CUT-OFF FREQUENCY AND PHASE SHIFT

$$f_c = \frac{1}{2\pi RC}$$

$$\text{Phase Shift } \phi = \arctan \frac{1}{2\pi fRC}$$

The circuit gain, A_v which is given as V_{out}/V_{in} (magnitude) and is calculated as:

$$A_v = \frac{V_{OUT}}{V_{IN}} = \frac{R}{\sqrt{R^2 + X_C^2}} = \frac{R}{Z}$$

at low f : $X_c \rightarrow \infty$, $V_{out} = 0$

at high f : $X_c \rightarrow 0$, $V_{out} = V_{in}$

HIGH PASS FILTER EXAMPLE.

Calculate the cut-off or “breakpoint” frequency (f_c) for a simple high pass filter consisting of an 82pF capacitor connected in series with a 240kΩ resistor.

$$f_c = \frac{1}{2\pi RC} = \frac{1}{2\pi \times 240,000 \times 82 \times 10^{-12}} = 8,087 \text{ Hz or } 8 \text{ kHz}$$

BAND PASS FILTERS

The cut-off frequency or f_c point in a simple RC passive filter can be accurately controlled using just a single resistor in series with a non-polarized capacitor, and depending upon which way around they are connected either a low pass or a high pass filter is obtained.

One simple use for these types of Passive Filters is in audio amplifier applications or circuits such as in loudspeaker crossover filters or pre-amplifier tone controls. Sometimes it is necessary to only pass a certain range of frequencies that do not begin at 0Hz, (DC) or end at some high frequency point but are within a certain frequency band, either narrow or wide.

By connecting or “cascading” together a single Low Pass Filter circuit with a High Pass Filter circuit, we can produce another type of passive RC filter that passes a selected range or “band” of frequencies that can be either narrow or wide while attenuating all those outside of this range. This new type of passive filter arrangement produces a frequency selective filter known commonly as a Band Pass Filter or BPF for short.

BAND PASS FILTER CIRCUIT

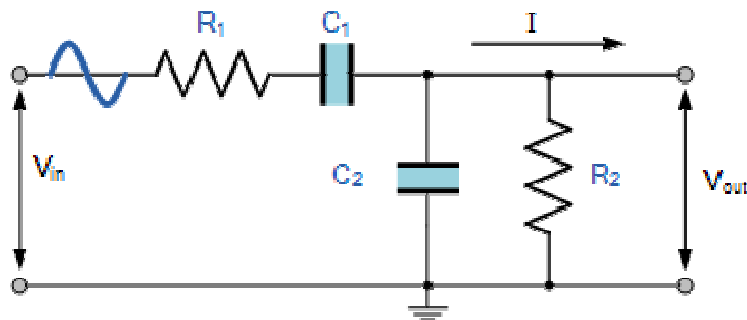

Unlike a low pass filter that only pass signals of a low frequency range or a high pass filter which pass signals of a higher frequency range, a Band Pass Filters passes signals within a certain “band” or “spread” of frequencies without distorting the input signal or introducing extra noise. This band of frequencies can be any width and is commonly known as the filters Bandwidth.

Bandwidth is commonly defined as the frequency range that exists between two specified frequency cut-off points (f_c), that are 3dB below the maximum centre or resonant peak while attenuating or weakening the others outside of these two points.

Then for widely spread frequencies, we can simply define the term “bandwidth”, BW as being the difference between the lower cut-off frequency (f_{LOWER}) and the higher cut-off frequency (f_{HIGHER}) points. In other words, $BW = f_H - f_L$. Clearly for a pass band filter to function correctly, the cut-off frequency of the low pass filter must be higher than the cut-off frequency for the high pass filter.

The “ideal” Band Pass Filter can also be used to isolate or filter out certain frequencies that lie within a particular band of frequencies, for example, noise

cancellation. Band pass filters are known generally as second-order filters, (two-pole) because they have “two” reactive component, the capacitors, within their circuit design. One capacitor in the low pass circuit and another capacitor in the high pass circuit.

Frequency Response of a 2nd Order Band Pass Filter.

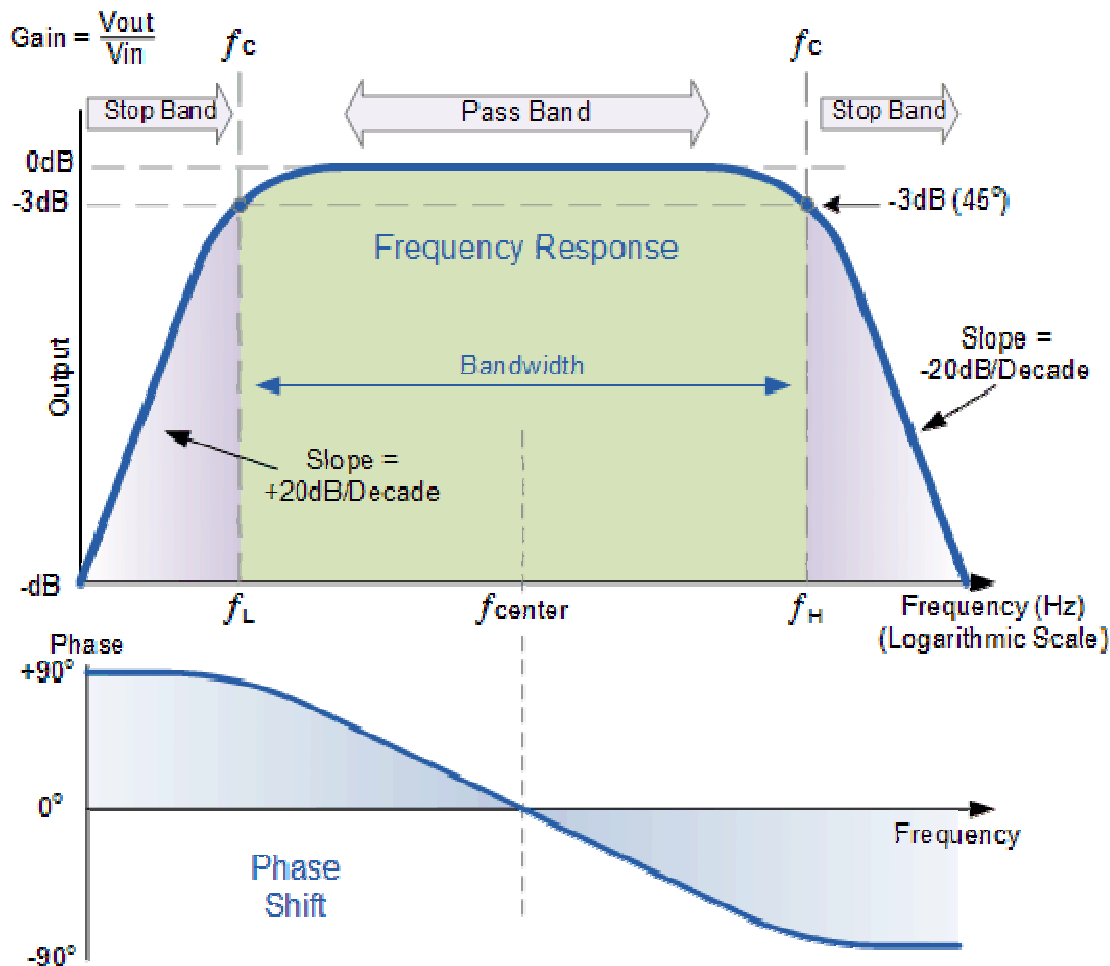

The Bode Plot or frequency response curve above shows the characteristics of the band pass filter. Here the signal is attenuated at low frequencies with the output increasing at a slope of +20dB/Decade (6dB/Octave) until the frequency reaches the “lower cut-off” point f_L . At this frequency the output voltage is again $1/\sqrt{2} = 70.7\%$ of the input signal value or -3dB ($20 \log (V_{out}/V_{in})$) of the input.

The output continues at maximum gain until it reaches the “upper cut-off” point f_H where the output decreases at a rate of -20dB/Decade (6dB/Octave) attenuating any high frequency signals. The point of maximum output gain is generally the geometric mean of the two -3dB value between the lower and upper cut-off points and is called the “Centre Frequency” or “Resonant Peak” value f_r . This geometric mean value is calculated as being $f_r^2 = f_{(UPPER)} \times f_{(LOWER)}$.

A band pass filter is regarded as a second-order (two-pole) type filter because it has “two” reactive components within its circuit structure, then the phase angle will be twice that of the previously seen first-order filters, i.e., **180°**. The phase

angle of the output signal LEADS that of the input by +90° up to the centre or resonant frequency, f_r point were it becomes “zero” degrees (0°) or “in-phase” and then changes to LAG the input by -90° as the output frequency increases.

The upper and lower cut-off frequency points for a band pass filter can be found using the same formula as that for both the low and high pass filters, For example.

$$f_c = \frac{1}{2\pi RC} \text{ Hz}$$

Then clearly, the width of the pass band of the filter can be controlled by the positioning of the two cut-off frequency points of the two filters.

Band Pass Filter Example

A second-order **band pass filter** is to be constructed using RC components that will only allow a range of frequencies to pass above 1kHz (1,000Hz) and below 30kHz (30,000Hz). Assuming that both the resistors have values of 10kΩ’s, calculate the values of the two capacitors required.

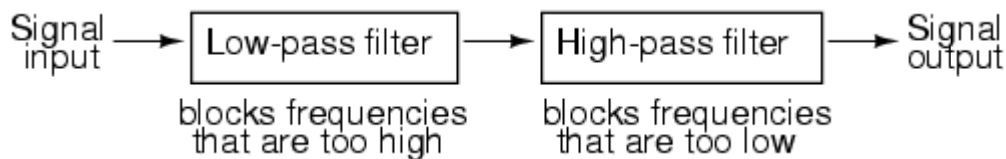

The High Pass Filter Stage

The value of the capacitor C1 required to give a cut-off frequency f_L of 1kHz with a resistor value of 10kΩ is calculated as:

$$C = \frac{1}{2\pi f_c R} = \frac{1}{2\pi \times 1,000 \times 10,000} = 15.8 \text{ nF}$$

Then, the values of R1 and C1 required for the high pass stage to give a cut-off frequency of 1.0kHz are: R1 = 10kΩ’s and C1 = 15nF.

The Low Pass Filter Stage

The value of the capacitor C2 required to give a cut-off frequency f_H of 30kHz with a resistor value of 10kΩ is calculated as:

$$C = \frac{1}{2\pi f_c R} = \frac{1}{2\pi \times 30,000 \times 10,000} = 510 \text{ pF}$$

Then, the values of R2 and C2 required for the low pass stage to give a cut-off frequency of 30kHz are, R = 10kΩ's and C = 510pF. However, the nearest preferred value of the calculated capacitor value of 510pF is 560pF so this is used instead.

With the values of both the resistances R1 and R2 given as 10kΩ, and the two values of the capacitors C1 and C2 found for the high pass and low pass filters as 15nF and 560pF respectively, then the circuit for our simple passive Band Pass Filter is given as.

Completed Band Pass Filter Circuit

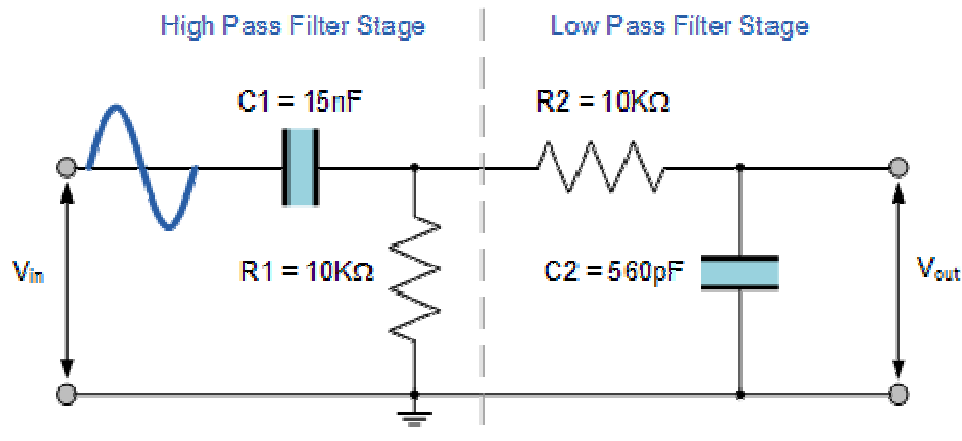

Band Pass Filter Resonant Frequency

We can also calculate the “Resonant” or “Centre Frequency” (f_r) point of the band pass filter where the output gain is at its maximum or peak value. This peak value is not the arithmetic average of the upper and lower -3dB cut-off points as you might expect but is in fact the “geometric” or mean value. This geometric mean value is calculated as being $f_r^2 = f_{C(\text{UPPER})} \times f_{C(\text{LOWER})}$ for example:

Centre Frequency Equation

$$f_r = \sqrt{f_L \times f_H}$$

- Where, f_r is the resonant or centre frequency
- f_L is the lower -3dB cut-off frequency point
- f_H is the upper -3db cut-off frequency point

And in our simple example above, the calculated cut-off frequencies were found to be $f_L = 1,060$ Hz and $f_H = 28,420$ Hz using the filter values.

Then by substituting these values into the above equation gives a central resonant frequency of:

$$f_r = \sqrt{f_L \times f_H} = \sqrt{1,060 \times 28,420} = 5,48 \text{ kHz}$$

Band-stop filters

It is so called *band-elimination*, *band-reject*, or *notch* filters; this kind of filter passes all frequencies above and below a particular range set by the component values. Not surprisingly, it can be made out of a low-pass and a high-pass filter, just like the band-pass design, except that this time we connect the two filter sections in parallel with each other instead of in series. (Figure below)

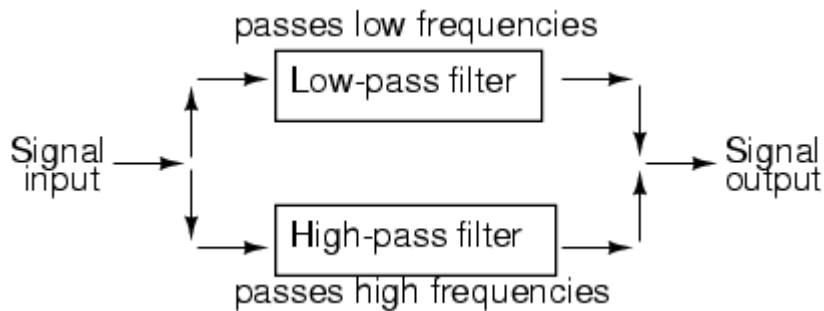

System level block diagram of a band-stop filter.

Constructed using two capacitive filter sections, it looks something like (Figure below).

