



# **KIIT POLYTECHNIC**

## **LECTURE NOTES ON B.ETC**

**Prepared by:- Mr. Jiban Kumar Jena,**

**Lecturer in Electronics & Telecommunication Engineering**

**Email ID :- [jiban.jenafet@kp.kiit.ac.in](mailto:jiban.jenafet@kp.kiit.ac.in)**

## CONTENTS

<b>Sl. No.</b>	<b>Name of Topic</b>	<b>Page No.</b>
<b>1.</b>	<b>Electronic Devices</b>	<b>03-12</b>
<b>2.</b>	<b>Electronic Circuits</b>	<b>13-25</b>
<b>3.</b>	<b>Communication System</b>	<b>26-30</b>
<b>4.</b>	<b>Trancerducers &amp; Measuring Instruments</b>	<b>31-42</b>

# CHAPTER-1

---

## 1. ELECTRONIC DEVICE

### 1.1 Basic Concept of Electronics and its application.

#### **Defination:**

The branch of engineering which deals with current conduction through a vacuum or gas or semiconductor is known as electronics. An electronic device is that in which current flows through a vacuum or gas or semiconductor.

(Or)

Electronics is the branch of science that deals with the study of the flow of electrons and their effects in a vacuum, gases, and semiconductor materials.

#### **Applications:**

Electronics has gained much importance due to its numerous applications in our daily life starting from home to any industry. For simplification we categorise them in some area such as

- **Consumer Electronics.**

Electronics devices which make our life easy and better such as air conditioner, cooking appliances, dryer, personal computer, mobile phones, etc.

- **Commercial applications.**

Electronic devices and gadgets are widely used for the commercial purpose such as Telephone, Airconditioning, heating, Digital Advertising, power supplies, Personal computer, MP3s, office equipment, light dimmer, uninterruptible power supplies (UPS), etc.

- **Medical applications.**

With the advancement of the electronics field, and particularly that of computer technology has made possible many of the application which made possible for nurses and doctors to examine his patient. Many machines like NMR, ECE, x-ray, etc use electronics. There is noticeable advancement of electronics in the field of medical sciences. There are a

few mindblowing innovations which prove how important is electronics – Robotic Arm, Robotic Check-Ups, Bionic Eye, Needle-Free Diabetes Care, etc.

- **Agriculture application.**

Electronics has proved to be the biggest problem solver in the agriculture field. Today number of electronics devices and sensors are used to monitor a crop or enhance the production of Agriculture. Like e-Agri Sensors and other electronic gadgets which are used for measuring the salinity of soil, moisture level, and nutrition level in the soil.

- **Industrial automation.**

Electronics applications are widely utilized in Arc and Industrial furnaces such as blowers, fans, pumps and compressors, industrial lasers, transformer tap changers, rolling mills, textile mills, excavators, cement mills, welding. Nowadays most of the firms use robotics technology Such as in the manufacturing of cars.

- **Communication.**

In order to communicate for far distance, Electronic devices and systems are used such as Am Radio, FM Radio, Television, processing, Memory storage, display, analysis, protection, etc.

- **Military & defence applications.**

Electronics devices and machinery are also widely used in the military such as UAV and drones which are used in the military for aerial attack as well as for monitoring. Magnetic anomaly detector, People sniffer, Night vision device, infrared detector, RADAR, PNS Hameed, and night vision camera etc. are some gadgets used by the military.

- **Automobiles.**

Electronics are used in road vehicles, such as Lighting system of the car, telematics, in-car sound systems, etc. Initially, electronics were used to in cars to control engines. Nowadays almost every things are controlled using electronics whether it's a chair in car or speed limitation in car, or Gas management in the car. Now electronic with its advancement.

- **Aerospace.**

Today with advancement in electronics engineering application in the field of aerospace has open many impossible ways to humans. Most of the parts used in the Space shuttle, Satellite power supplies, aircraft power management, and other communication instruments

are electronics devices. Even in commercial airlines, there are numerous electronic devices which are used to measure different physical parameters like humidity, temperature, pressure, elevation, etc.

## 1.2 Basic Concept of Electron

### Emission & its types.

**Electron emission** is defined as the liberation of electrons from any surface of a substance.

Any metal consists of plenty of free electrons. Even at room temperature, these free electrons moves randomly inside the metal

from one atom to another but can not leave the surface of the metal to provide electron emission.

This is because the free electrons reach the extreme boundary of the metal are pulled back by the positive nuclei behind them & their kinetic energy decreases.

Thus at the surface of a metal, a free electron encounters forces that prevent it to leave the metal. In other words, the metallic surface offers a barrier to free electrons and is known as surface barrier.

However, if sufficient external energy is given to the free electron, its kinetic energy is increased and thus electron will cross over the surface barrier to leave the metal. This additional energy required by an electron to overcome the surface barrier of the metal is called work function of the metal.

The amount of additional energy required to emit an electron from a metallic surface is known as work function of that metal.

### Types of Electron Emission.

The process of emission happens by supplying Energy equal to or greater than the work function to the metal & the electron absorbs the energy, thus able to overcome the surface barrier and leaves the metal surface. Depending on the process of supplying external energy to the metal surface, the emission is of different types.

#### (i) Thermionic Emission.

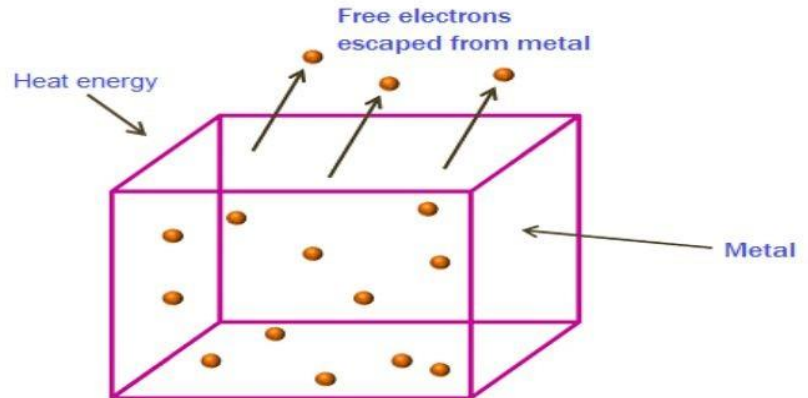

The process of electron emission from a metal surface by supplying thermal energy to it is known as thermionic emission.

In this method, the metal is heated to sufficient temperature (about  $2500^{\circ}\text{C}$ ) to enable the free electrons to leave the metal surface. The number of electrons emitted depends upon the temperature. The higher the temperature, the greater is the emission of electrons. This type of emission is employed in vacuum tubes.

### (ii) Field emission.

The process of electron emission by the application of strong electric field at the surface of a metal is known as field emission.

In this method, when a sufficiently high positive charge is placed in front of the emitter surface, due to the strong electrostatic force of the created electric field, the free electron can get sufficient energy to overcome the surface barrier and can get emitted from the surface of the emitter body. As this type of electron emission is caused by the electric field present in the space, it is called field emission. The stronger the electric field, the greater is the electron emission.

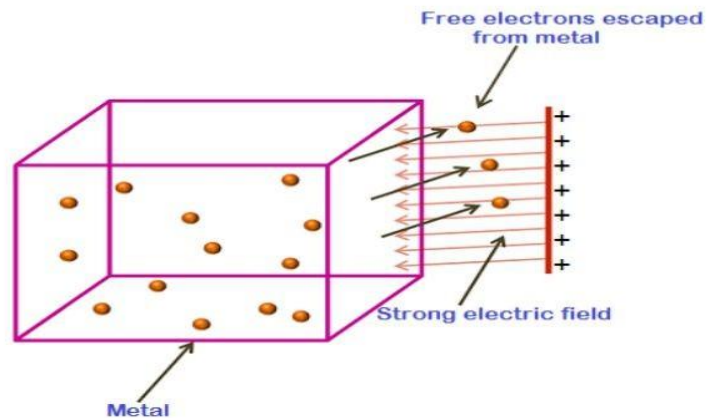

### (iii) Secondary emission.

Electron emission from a metallic surface by the bombardment of high-speed electrons or other particles is known as secondary emission.

In this method, When a beam of high-velocity electrons strikes on the metal surface, the kinetic energy of high

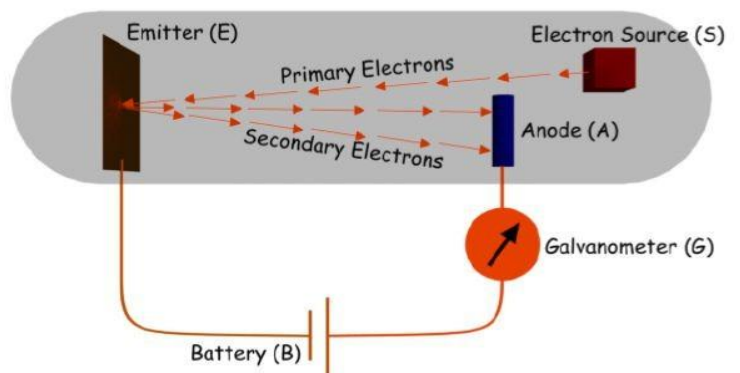



velocity striking electrons, transferred to the free electrons on the metal surface. Thus the free electrons may get sufficient kinetic energy to overcome the surface barrier and knocked out from the surface & start electron emission.

This type of emission is known as secondary electron emission. The electrons that strike the metal are called primary electrons while the emitted electrons are known as secondary electrons.

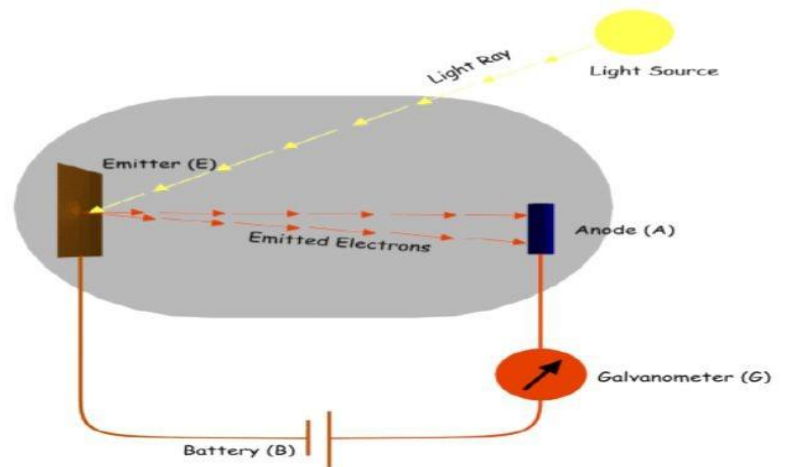

#### (iv) Photo-electric emission.

Electron emission from a metallic surface by the application of light is known as photo electric emission.

In this method, the energy of light falling upon the metal surface is transferred to the free electrons within the metal to enable them to leave the surface. The greater the intensity (i.e. brightness) of light beam falling on the metal surface, the greater is the photo-electric emission.

### 1.3 Classification of material according to electrical conductivity (Conductor, Semiconductor & Insulator) with respect to energy band diagram only.

For better understanding of classification we have to understand what is energy band and different types of bands present in a metal.

**Energy Band:** The range of energies possessed by an electron in a solid is known as **energy band**.

**Valence band:** The range of energies (i.e. band) possessed by valence electrons is known as **valence band**.

**Conduction band:** The range of energies (i.e. band) possessed by conduction band electrons is known as **conduction band**.

**Forbidden energy gap:** The separation between conduction band and valence band on the energy level diagram is known as **forbidden energy gap**.

**(i) Insulators.** Insulators (e.g. wood, glass etc.) are those substances which do not allow the passage of electric current through them. In terms of energy band, the valence band is full while the conduction band is empty. Further, the energy gap between valence and conduction bands is very large (15 eV). Therefore, a very high electric field is required to push the valence electrons to the conduction band.

However, when the temperature is raised, some of the valence electrons may acquire enough energy to cross over to the conduction band. Hence, the resistance of an insulator decreases with the increase in temperature *i.e.* an insulator has negative temperature coefficient of resistance.

**(ii) Conductors.** Conductors (e.g. copper, aluminium) are those substances which easily allow the passage of electric current through them. It is because there are a large number of free electrons available in a conductor. In terms of energy band, the valence and conduction bands overlap each other. Due to this overlapping, a slight potential difference across a conductor causes the free electrons to constitute electric current.

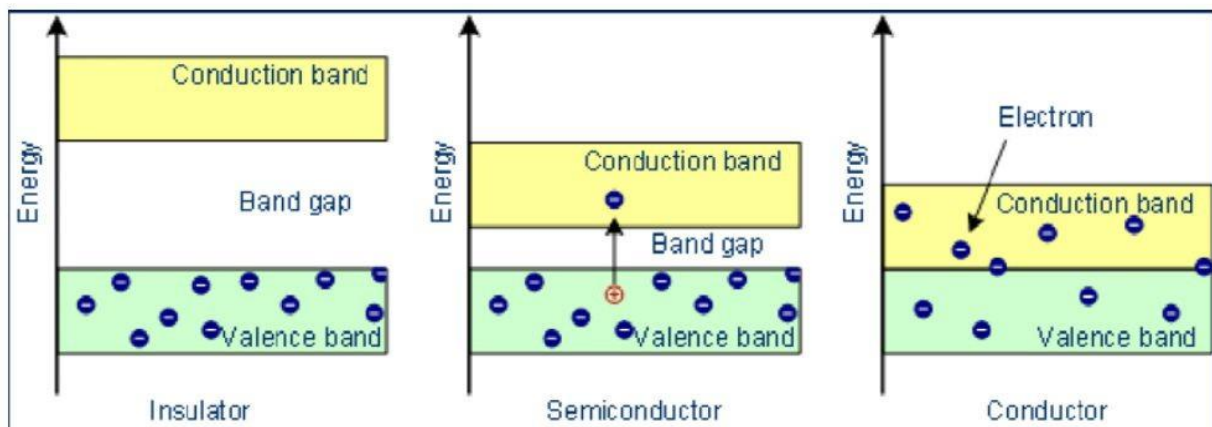

**(iii) Semiconductors.** Semiconductors (e.g. germanium, silicon etc.) are those substances whose electrical conductivity lies in between conductors and insulators. In terms of energy band, the valence band is almost filled and conduction band is almost empty. Further, the energy gap between valence and conduction bands is very small. Therefore, comparatively smaller electric field (smaller than insulators but much greater than conductors) is required to push the electrons from the valence band to the conduction band. In short, a semiconductor has :

- (a) almost full valence band
- (b) almost empty conduction band



(c) small energy gap (1 eV) between valence and conduction bands.

At low temperature, the valence band is completely full and conduction band is completely empty. Therefore, a semiconductor virtually behaves as an insulator at low temperatures. However, even at room temperature, some electrons (about one electron for 10<sup>10</sup> atoms) cross over to the conduction band, imparting little conductivity to the semiconductor.

### 1.4 Difference between Intrinsic & Extrinsic Semiconductor.

#### Intrinsic Semiconductor:

A semiconductor in an extremely pure form is known as an **intrinsic semiconductor**. In an intrinsic semiconductor, even at room temperature, hole-electron pairs are created. When electric field is applied across an intrinsic semiconductor, the current conduction takes place by two processes, namely; by *free electrons* and *holes*. The free electrons are produced due to the breaking up of some covalent bonds by thermal energy. At the same time, holes are created in the covalent bonds. Under the influence of electric field, conduction through the semiconductor is by both free electrons and holes. Therefore, the total current inside the semiconductor is the sum of currents due to free electrons and holes.

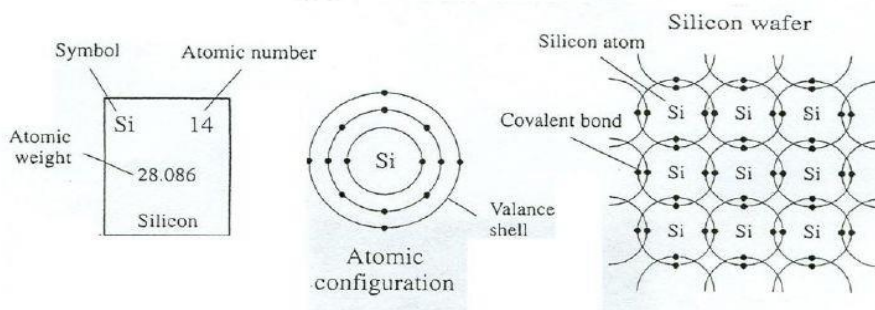

#### Extrinsic Semiconductor:

When a small amount of impurity is added to a pure semiconductor it becomes **extrinsic semiconductor**.

The intrinsic semiconductor has little current conductivity at room temperature, to make it suitable for electronic applications we must change its conducting properties. This is achieved

by adding a small amount of suitable impurity to a semiconductor. It is then called impurity or extrinsic semiconductor. The process of adding impurities to a semiconductor is known as doping.

The purpose of adding impurity is to increase either the number of free electrons or holes in the semiconductor crystal. If a pentavalent impurity (having 5 valence electrons) is added to the semiconductor, a large number of free electrons are produced in the semiconductor. If a trivalent impurity (having 3 valence electrons) is added to the semiconductor, large number of holes are produced in the semiconductor crystal. Depending upon the type of impurity added, extrinsic semiconductors are classified into:

- (i) n-type semiconductor                      (ii) p-type semiconductor

### (i) n-type Semiconductor

When a small amount of pentavalent impurity is added to a pure semiconductor, it is known as n-type semiconductor.

The addition of pentavalent impurity provides a large number of free electrons in the semiconductor crystal. Typical examples of pentavalent impurities are arsenic, antimony, Bismuth and Phosphorous etc. Such impurities which produce n-type semiconductor are known as donor impurities because they donate or provide free electrons to the semiconductor crystal. In n-type semiconductor electrons are said to be the majority carriers whereas holes are the minority carriers.

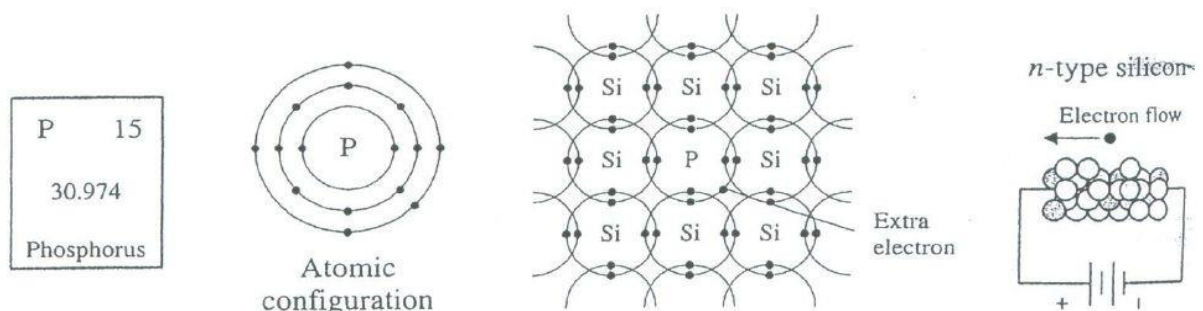

### (ii) p-type Semiconductor

When a small amount of trivalent impurity is added to a pure semiconductor, it is called p-type Semiconductor.

The addition of trivalent impurity provides a large number of holes in the semiconductor. Typical examples of trivalent impurities are gallium, indium, boron etc. Such impurities which produce p-type semiconductor are known as acceptor impurities because the holes created can accept the electrons. In p-type semiconductor holes are the majority carriers whereas electrons are said to be the minority carriers.

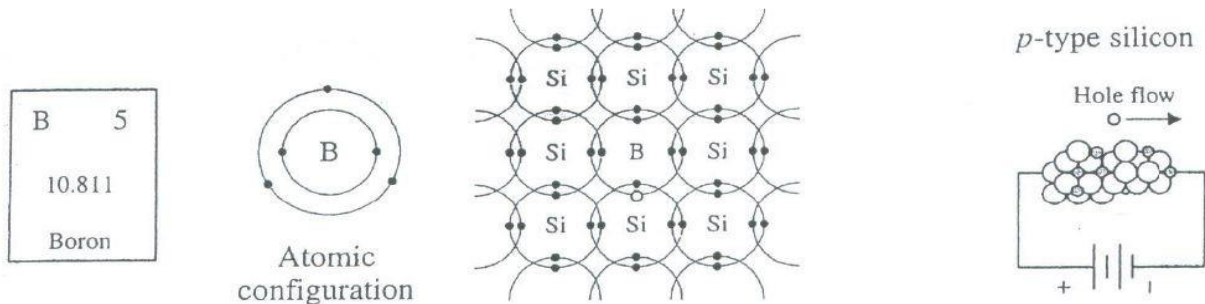

**Difference between Intrinsic & Extrinsic Semiconductor.**

S.No	Intrinsic Semiconductor	Extrinsic Semiconductor
1.	Semiconductor in a pure form is called intrinsic semiconductor.	Semiconductor which are doped with impurity is called extrinsic semiconductor
2.	Here the charge carriers are produced only due to thermal agitation.	Here the charge carriers are produced due to impurities and may also be produced due to thermal agitation.
3.	They have low electrical conductivity.	They have high electrical conductivity.
4.	They have low operating temperature.	They have high operating temperature.
5.	At 0K, Fermi level exactly lies between conduction band and valence band.	At 0K, Fermi level exactly lies closer to conduction band in "n" type semiconductor and lies near valence band in "p" type semiconductor.
	<b>Examples:</b> Si,Ge,etc.	<b>Examples:</b> Si and Ge doped with Al, In,P,As etc

### 1.5 Difference between vacuum tube & semiconductor.

Vacuum tube	Semiconductor
<ul style="list-style-type: none"> <li>Power consumption is high and heat wastage is comparatively high</li> </ul>	<ul style="list-style-type: none"> <li>Lower power consumption, less wastage of heat</li> </ul>
<ul style="list-style-type: none"> <li>Large size than transistor</li> </ul>	<ul style="list-style-type: none"> <li>Size is so small as compared to vacuum tubes.</li> </ul>
<ul style="list-style-type: none"> <li>High cost.</li> </ul>	<ul style="list-style-type: none"> <li>Low cost.</li> </ul>
<ul style="list-style-type: none"> <li>Less suitable for portable products.</li> </ul>	<ul style="list-style-type: none"> <li>Suitable for portable device.</li> </ul>
<ul style="list-style-type: none"> <li>It requires the high voltage power supply, not suitable for smaller voltage devices.</li> </ul>	<ul style="list-style-type: none"> <li>It requires a lower power supply, suitable for smaller voltage devices</li> </ul>
<ul style="list-style-type: none"> <li>Low voltage gain</li> </ul>	<ul style="list-style-type: none"> <li>High voltage gain</li> </ul>
<ul style="list-style-type: none"> <li>There is glass tube in a vacuum tube so not that much physical strength.</li> </ul>	<ul style="list-style-type: none"> <li>Physical strength is high</li> </ul>
<ul style="list-style-type: none"> <li>Not that much depend upon temperature</li> </ul>	<ul style="list-style-type: none"> <li>Depend upon Temperature</li> </ul>
<ul style="list-style-type: none"> <li>High input impedance</li> </ul>	<ul style="list-style-type: none"> <li>Low input impedance</li> </ul>
<ul style="list-style-type: none"> <li>Made up of wires.</li> </ul>	<ul style="list-style-type: none"> <li>Made up of PN junction.</li> </ul>
<ul style="list-style-type: none"> <li>Vacuum tubes can easily be replaced by a user</li> </ul>	<ul style="list-style-type: none"> <li>Relatively maintenance more difficult, cannot easily be replaced by a user.</li> </ul>



# CHAPTER-2

---

## 2. ELECTRONIC CIRCUITS

### 2.1 Rectifier & its uses.

#### Rectifier

A rectifier is an electrical device that converts an Alternating Current (AC) into a Direct Current (DC) by using one or more P-N junction diodes.

When AC voltage or AC current is applied across the P-N junction diode, during the positive half cycle the diode is forward biased and allows electric current through it. However, when the AC current reverses its direction to negative half cycle, the diode is reverse biased and does not allow electric current through it. Thus, electric current flows through the diode only during the positive half cycle of the AC current.

This current which flows across the diode is nothing but a DC current. Thus, the P-N junction diode acts like a rectifier by converting the AC current into DC current.

Rectifiers are mostly used to provide continuous voltage (DC Voltage) required to run almost all electronic devices & circuits.

### 2.2 Principles of working of different types of Rectifiers with their merits and demerits

**Types of Rectifier:** The rectifiers are mainly classified into two types:

- (i) Half wave rectifier
- (ii) Full wave rectifier

#### Half Wave Rectifier

As the name suggests, the half wave rectifier is a type of rectifier which converts half of the AC input signal (positive half cycle) into pulsating DC output signal and the remaining half signal (negative half cycle) is blocked or lost. A half-wave rectifier is the simplest of them all as it is composed of only a single diode.



### Operation

During the positive half cycle, the diode terminal anode will become positive and the cathode will become negative known as forward bias. And it will allow the positive cycle to flow through the diode.

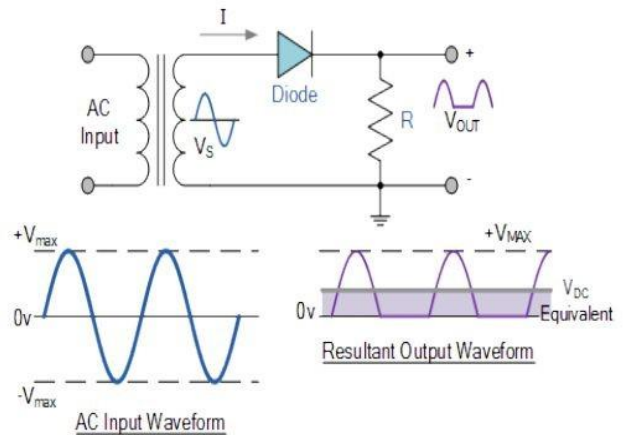

During the negative half cycle, the anode will become negative and the cathode will become positive, which is known as reverse bias. So the diode will block the negative cycle.

In this way rectifier allows only the positive half cycle of the input AC voltage supply. It uses only half of the input voltage the other half is wasted.

### Merits

- Simple circuit as it uses less no of components.
- Low cost

### Demerits

- It only allow +ve half-cycle and wasted the -ve half-cycle which leads to power loss.
- Produce low output voltage
- Output is not purely DC, it has high ripple factor.

### Full wave rectifier

The full wave rectifier is a type of rectifier which converts the full AC input signal (positive half cycle and negative half cycle) to pulsating DC output signal. Unlike the half wave rectifier, the input signal is not wasted in full wave rectifier. The efficiency of full wave rectifier is high as compared to the half wave rectifier. A full wave rectifier is made up of more than one diode.

There are two types of full wave rectifier.

1. Center-Tap Rectifier
2. Bridge Rectifier

### Center-Tap Full Wave Rectifier

This type of rectifier circuit uses a transformer with secondary winding tapped at the center point & two diodes as shown in figure.

### Operation

The full wave rectifier circuit consists of two *power diodes* connected to a single load resistance (RL) with each diode taking it in turn to supply current to the load. When point A of the transformer is positive with respect to point C, diode D1 conducts in the forward direction as indicated by the arrows. When point B is positive (in the negative half of the cycle) with respect to point C, diode D2 conducts in the forward direction and the current flowing through resistor R is in the same direction for both half-cycles.

### Merits

- Low ripples in the output DC signal
- Rectifier efficiency is doubled as compare to half wave rectifier.
- Low power loss

### Demerits

- It is expensive as it uses center tapped transformer.
- The output voltage is half of the secondary voltage, as each diode utilizes only one half of the transformer secondary voltage.

### Bridge Type Full Wave Rectifier

This type of single phase rectifier uses four individual rectifying diodes connected in a “bridge” configuration as shown in figure. The main advantage of this bridge circuit is that it does not require a special centre tapped transformer, thereby reducing its size and cost.

### Operation

The four diodes labelled D1 to D4 are arranged in “series pairs” with only two diodes conducting current during each half cycle.

During the positive half cycle of the supply, diodes D1 and D2 conduct in series while diodes D3 and D4 are reverse biased and the current flows through the load as shown in figure.

During the negative half cycle of the supply, diodes D3 and D4 conduct in series, but diodes D1 and D2 switch “OFF” as they are now reverse biased. The current flowing through the load is the same direction as during the positive half cycle as shown in figure.

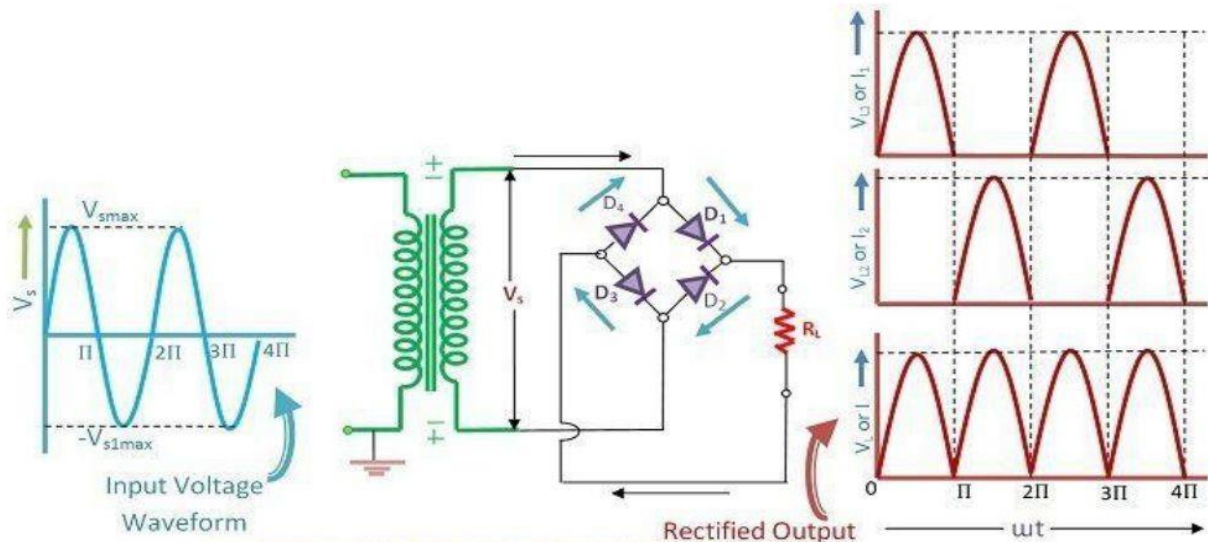

### Merits

- High rectifier efficiency.
- Low power loss as compared to half wave rectifier.

### Demerits

- Since four diodes are used, cost is high.
- The output is not a proper DC quantity. It has ripples in its output.
- More power loss compared to centre tapped full wave rectifier.

## 2.3 Functions of filters and classification of simple Filter circuit (Capacitor, Choke input and $\pi$ )

### Filters

A **filter circuit** is a device which removes the a.c. component of rectifier output but allows the d.c. component to reach the load.

It is connected between rectifier and load because the output of a rectifier has pulsating character i.e. it contains a.c. and d.c. components. The a.c. component is undesirable and must be kept away from the load. To do so, a filter circuit is used which removes (or filters out) the a.c. component and allows only the d.c. component to reach the load.

A filter circuit is generally a combination of inductors (L) and capacitors (C). A capacitor passes a.c. readily but does not pass d.c. at all. On the other hand, an inductor opposes a.c. but allows d.c. to pass through it. It then becomes clear that suitable network of L and C can effectively remove the a.c. component & allowing the d.c. component to reach the load.

**Classification of Filters**

**i. Shunt Capacitor:**

It is also called Capacitor Filter. It offers low reactance to ac & a very high reactance to the dc component. The capacitive reactance is  $X_C = 1/2\pi fc$ , for d.c,  $f=0$  Then,  $X_C = \infty$

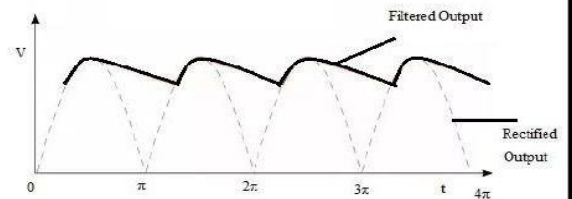
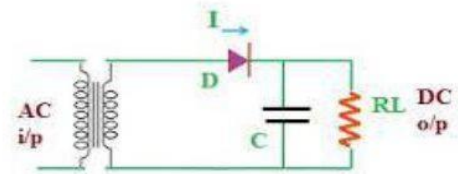

Hence a capacitor does not allow the d.c to pass through it. When the pulsating output is applied the ac component experience a resistive path so bypass through the capacitor but the dc component is blocked by capacitor and appears at load. In this way the the undesired ac component is removed.

**ii. Choke input filter:**

It consists of a choke L connected in series with the rectifier output and a filter capacitor C across the load. The inductive reactance is  $X_L = 2\pi fL$ , for d.c,  $f(\text{frequency})=0$  Then,  $X_L = 0$

Hence inductor allows the d.c to pass through it & blocks ac. When the pulsating output is applied the ac component is blocked by the series Inductor L, only dc component passes through it. If the resultant output have any ac component it bypass through the parallel capacitor C and the pure dc component will appear across load.

**iii. Capacitor input filter:**

It consists of a filter capacitor  $C_1$  connected across the rectifier output, a choke L

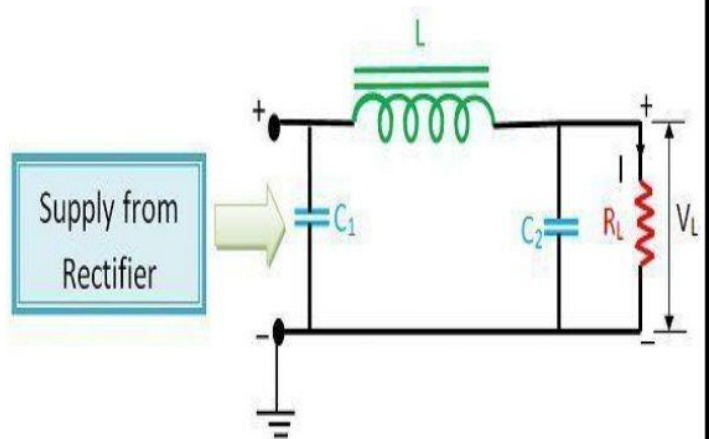



in series and another filter capacitor  $C_2$  connected across the load. The shape of the circuit diagram of this filter circuit appears like Greek letter  $\pi$  ( $\pi$ ) and hence the name  $\pi$ -filter.

Here pulsating output from rectifier is applied across 1st capacitor  $C_1$  which offers zero reactance to a.c & infinite reactance to d.c. Hence d.c component continues to reach across (Choke Filter)  $L$ . The filter choke then allows the d.c component easily by blocking a.c component if any. Finally the 2nd capacitor  $C_2$  across load bypasses the a.c component if any which the choke ( $L$ ) failed to block by making d.c component to reach across load.

#### 2.4 Working of D.C power supply system (unregulated) with help of block diagrams only

Almost all household electronic circuits need an unregulated AC to be converted to constant DC in order to operate. All devices will have certain power supply Limit and the inside circuit must be able to supply dc voltage within this limit. This DC supply is regulated & limited in terms of voltage and current but the mains supply may be fluctuating may cause damage to the electronic circuit. This job is done by a unregulated power supply.

The DC power supply is practically converted to each & every stage in the system. All low power system can be run with a battery but batteries are expensive & frequently replaced. So the best method is a unregulated power supply.

A unregulated power supply is a combination of 3 parts namely a transformer, a rectifier & a filter circuit. The Block diagram of a unregulated power supply is shown in figure.

#### Unregulated Power Supply - Block Diagram

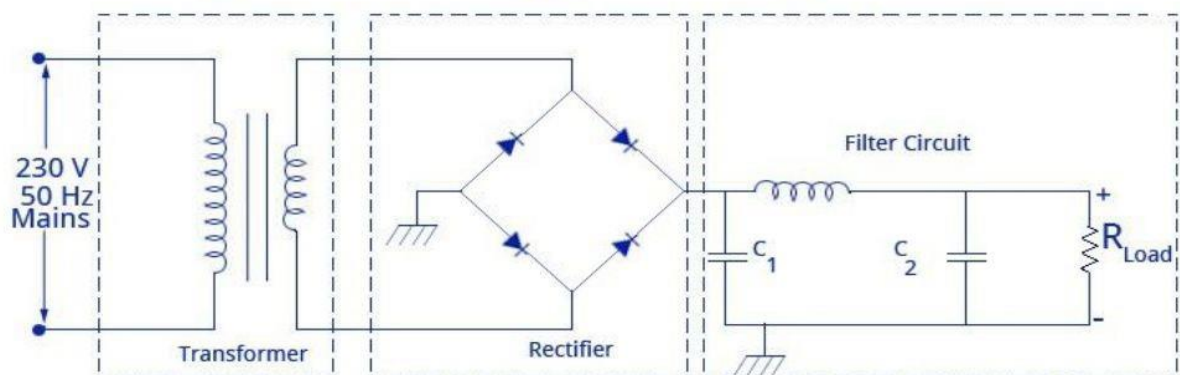



A small step down transformer is used to reduce the voltage level as the device needed. The output of the transformer is a pulsating AC voltage which is fed into a rectifier circuit. The rectifier converts it and its output is pulsating DC. Again this output is fed to a filter circuit as input. This filter circuit then removes the AC components present if any and gives a DC voltage as required by the electronic circuit.

## 2.5 Transistor, Different types of Transistor Configuration and state output and input current gain relationship in CE, CB and CC configuration (No mathematical derivation)

### Transistor

The transistor is a three terminal semiconductor device that regulates current or voltage flow and acts as a switch or gate for signals. The transistor is a semiconductor device which transfers a weak signal from a low resistance circuit to a high resistance circuit. The words **trans** mean **transfer property** and **istor** mean **resistance property** offered to the junctions.

### Construction

A transistor consists of two pn junctions formed by sandwiching either p-type or n-type semiconductor between a pair of opposite types. Also we can say the transistor consists of two PN diodes connected back to back. Hence it has got two PN junctions.

Accordingly there are two types of transistors namely ;

- (i) n-p-n transistor
- (ii) p-n-p transistor

An *n-p-n* transistor is composed of two *n*-type semiconductors separated by a thin section of *p*-type and a *p-n-p* transistor is formed by two *p*-sections separated by a thin section of *n*-type as shown in Figure.

The three terminals drawn from the transistor indicate Emitter (E), Base (B) and Collector (C) terminals. They have their functionality as discussed below.

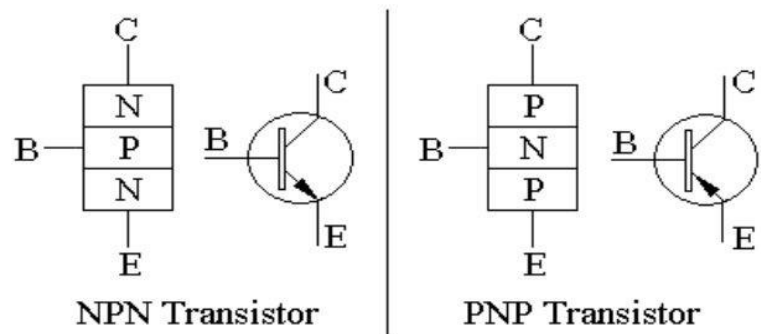

**Emitter**

- The left-hand side of the above shown structure can be understood as Emitter.
- This has a moderate size and is heavily doped as its main function is to supply a number of majority carriers, i.e. either electrons or holes.
- As this emits electrons, it is called as an Emitter.
- This is simply indicated with the letter **E**.

**Base**

- The middle material in the above figure is the Base.
- This is thin and lightly doped.
- Its main function is to pass the majority carriers from the emitter to the collector.
- This is indicated by the letter **B**.

**Collector**

- The right side material in the above figure can be understood as a Collector.
- Its name implies its function of collecting the carriers.
- This is a bit larger in size than emitter and base. It is moderately doped.
- This is indicated by the letter **C**.

The emitter-base junction is always forward bias whereas the collector-base junction is always reverse bias. The arrow in the symbol indicates the direction of flow of conventional current in the emitter with forward biasing applied to the emitter-base junction. The only difference between the NPN and PNP transistor is in the direction of the current.

**Working of NPN Transistor**

- Here emitter-base junction is forward biased and collector-base junction is reverse biased.
- The voltage  $V_{EE}$  provides a negative potential at the emitter which repels the electrons in the N-type material and these electrons cross the emitter-base junction, to reach the base region.
- There, a very low percent of electrons re-combine with free holes of P-region. This provides very low current which constitutes the base current  $I_B$ .
- The remaining holes cross the collector-base junction, to constitute the collector current  $I_C$ .

- As an electron reaches out of the collector terminal, and enters the positive terminal of the battery, an electron from the negative terminal of the battery  $V_{EE}$  enters the emitter

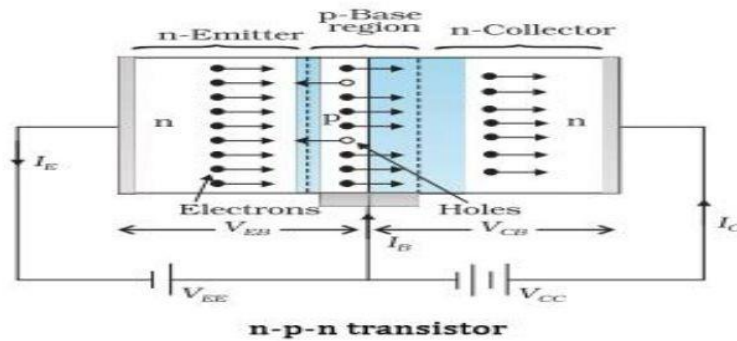

increases and the electron current flows through the transistor.

- Using Kirchhoff's Current Law we get  $I_E = I_B + I_C$

#### Working of PNP Transistor

- Here emitter-base junction is forward biased and collector-base junction is reverse biased.
- The voltage  $V_{EE}$  provides a positive potential at the emitter which repels the holes in the P-type material and these holes cross the emitter-base junction, to reach the base region.
- There a very low percent of holes re-combine with free electrons of N-region. This provides very low current which constitutes the base current  $I_B$ .
- The remaining holes cross the collector-base junction, to constitute collector current  $I_C$ , which is the hole current.
- As a hole reaches the collector terminal, an electron from the battery negative terminal fills the space in the collector. This flow slowly increases and the electron minority current flows through the emitter, where each electron entering the positive terminal of  $V_{EE}$ , is replaced by a hole by moving towards the emitter junction. This constitutes emitter current  $I_E$ .
- Here also if we applying Kirchhoff's Current Law we get  $I_E = I_B + I_C$
- 

#### Different Transistor Configurations

There are three leads in a transistor named as Emitter, Base and Collector terminals. However, when a transistor is to be connected in a circuit, we require four terminals, two for the input and two for the output. This difficulty is overcome by making one terminal of the transistor common to both input and output. The input is fed between this common terminal and one of the other two terminals. The output is obtained between the common terminal and the remaining terminal.

Accordingly, There are three different configurations of Transistors.

- **Common Base (CB) Configuration:** no current gain but voltage gain
- **Common Emitter (CE) Configuration:** current gain and voltage gain
- **Common Collector (CC) Configuration:** current gain but no voltage gain

### Common Base (CB) Configuration

As its name suggests, in the Common Base or grounded base configuration, the BASE connection is common to both the input signal AND the output signal with the input signal being applied between the base and the emitter terminals. The corresponding output signal is taken from between the base and the collector terminals as shown with the base terminal grounded or connected to a fixed reference voltage point.

The ratio of change in collector current ( $\Delta I_C$ ) to the change in emitter current ( $\Delta I_E$ ) at constant collector-base voltage ( $V_{CB}$ ) is known as **current amplification factor** in common base (CB) arrangement. i.e.  $\alpha = \Delta I_C / \Delta I_E$

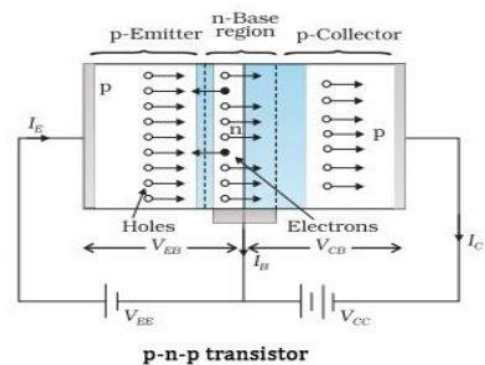

### Common Emitter (CE) Configuration

In the Common Emitter or grounded emitter configuration, the input signal is applied between the base and the emitter, while the output is taken from between the collector and the emitter as shown. This type of configuration is the most commonly used circuit for transistor based amplifiers and which represents the “normal” method of bipolar transistor connection.

The ratio of change in collector current ( $\Delta I_C$ ) to the change in base current ( $\Delta I_B$ ) is known as **base current amplification factor** i.e.  $\beta = \Delta I_C / \Delta I_B$

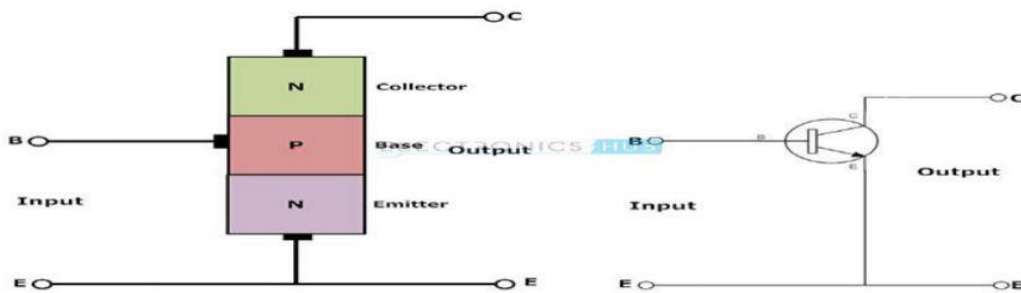

### Common Collector (CC) Configuration

In the Common Collector or grounded collector configuration, the collector is now common through the supply. The input signal is connected directly to the base, while the output is taken from the emitter load as shown. This type of configuration is commonly known as a Voltage Follower or Emitter Follower circuit: The emitter follower is a current amplifier that has no voltage gain.

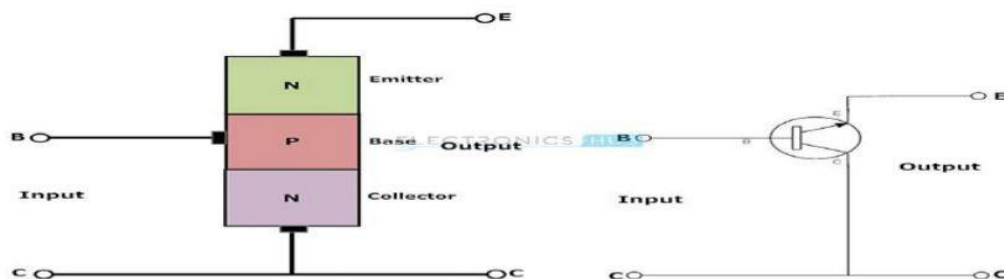



The ratio of change in emitter current ( $\Delta I_E$ ) to the change in base current ( $\Delta I_B$ ) is known as **current amplification factor** in common collector (CC) arrangement i.e.  $\gamma = \Delta I_E / \Delta I_B$

### Relation between $\alpha$ , $\beta$ and $\gamma$

Relation between  $\alpha$  and  $\beta$ :  $\beta = \frac{\alpha}{1-\alpha}$  also  $\alpha = \frac{\beta}{1+\beta}$

Relation between  $\alpha$  and  $\gamma$ :  $\gamma = \frac{1}{1-\alpha}$  also  $\alpha = \frac{\gamma-1}{\gamma}$

Relation between  $\beta$  and  $\gamma$ :  $\gamma = 1 + \beta$  also  $\beta = \gamma - 1$

Relation between  $\alpha, \beta$  and  $\gamma$ :  $\alpha = \frac{\beta}{1+\beta}$ ,  $\beta = \frac{\alpha}{1-\alpha}$ ,  $\gamma = \frac{1}{1-\alpha}$ ,  $\beta = \alpha \times \gamma$ ,  $\gamma = 1 + \beta$ ,  $\beta = \gamma - 1$

## 2.6 Need of biasing and explain different types of biasing with circuit diagram. (only CE configuration)

### Biasing

**Biasing** is the application of external dc supply to establish a fixed level of current and voltage. Transistor operates only at a particular point of the characteristics called operating point or Q-point/ Quiescent point. The circuit which provides transistor biasing is called as **Biasing Circuit**.

### Need for DC biasing

If a signal of very small voltage is given to the input of a transistor, it cannot be amplified. Because, to amplify a signal a transistor must satisfy these two conditions.

- The input voltage should exceed **cut-in voltage** for the transistor to be **ON**.
- The BJT should be in the **active region**, to be operated as an **amplifier**.

If appropriate DC voltages and currents are given through BJT by external sources, so that BJT operates in active region and superimpose the AC signals to be amplified, then this problem can be avoided. The given DC voltage and currents are so chosen that the transistor remains in active region for entire input AC cycle. Hence DC biasing is needed.

The below figure shows a transistor amplifier that is provided with DC biasing on both input and output circuits.

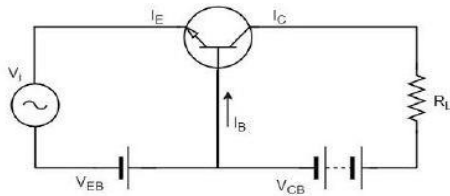

For a transistor to be operated as a faithful amplifier, the operating point should be stabilized.

### Types of Biasing

Transistor biasing was done with the aid of a battery  $V_{BB}$  which was separate from the battery  $V_{CC}$  used in the output circuit. However, in the interest of simplicity and economy, it is desirable that transistor circuit should have a single source of supply. The following are the most commonly used methods of obtaining transistor biasing from one source of supply (*i.e.*  $V_{CC}$ )

- i. Base resistor method
- ii. Emitter bias method
- iii. Biasing with collector-feedback resistor method
- iv. Voltage-divider bias method

#### Base Resistor Method

In this method, a high resistance  $R_B$  is connected between the base and +ve end of supply for  $npn$  transistor and between base and negative end of supply for  $pnp$  transistor. Here, the required zero signal base current is provided by  $V_{CC}$  and it flows through  $R_B$ . It is because now base is positive *w.r.t.* emitter *i.e.* base-emitter junction is forward biased. The required value of zero signal base current  $I_B$  (and hence  $I_C = \beta I_B$ ) can be made to flow by selecting the proper value of base resistor  $R_B$ .

#### Base Emitter Loop:

Applying KVL we have

$$V_{CC} - I_B R_B - V_{BE} = 0$$

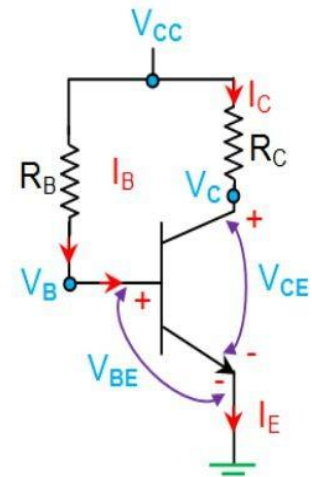

# CHAPTER-3

## 3.COMMUNICATION SYSTEM

### 3.1 Basic communication system (concept & explanation with help of Block diagram)

The communication system is a system which describes the information exchange between two points. The process of transmission and reception of information is called communication. The major elements of communication are the **Transmitter** of information, **Channel or medium** of communication and the **Receiver** of information.

#### Block Diagram of Communication Systems

The block diagram given below represents the flow of the signal from the source to the destination.

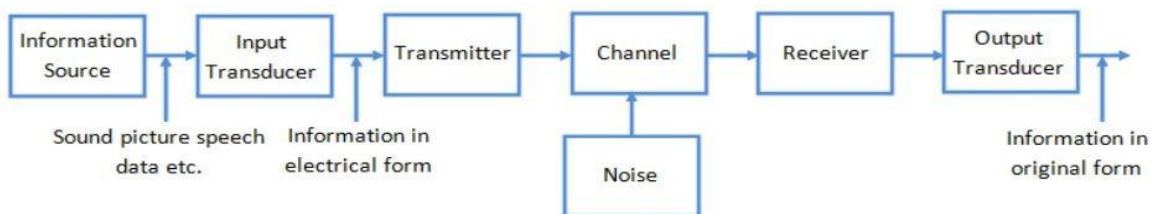

The essential components of a communication system are information source, input transducer, transmitter, communication channel, receiver and destination.

#### Information Source

- Message or information is the entity that is to be transmitted. It can be in the form of audio, video, temperature, picture, pressure, etc.

#### Input Transducer

- A transducer is a device which converts one form of energy into another form.
- The message from the information source may or may not be electrical in nature. In a case when the message produced by the information source is not electrical in nature, an input transducer is used to convert it into a time-varying electrical signal.

- Example: microphone converts the information or message which is in the form of sound waves into corresponding electrical signal.

**Transmitter**

- It is the arrangement that processes the message signal into a suitable form for transmission and subsequently reception.
- Modulation is the main function of the transmitter. In modulation, the message signal is superimposed upon the high-frequency carrier signal.

**Channel**

- A channel refers to a physical medium such as wire, cables, space through which the signal is passed from transmitter to the receiver.
- There are many channel impairments that affect the channel performance to a pronounced level. Noise, Attenuation and distortion to mention the major impairments.

**Noise**

- Noise is an unwanted signal which tends to interfere with the required signal. Noise signal is always random in character. Noise may interfere with signal at any point in a communication system.

**Receiver**

- An arrangement that extracts the message or information from the transmitted signal at the output end of the channel and reproduces it in a suitable form as the original message signal is a receiver.
- The main function of the receiver is to reproduce the message signal in electrical form from the distorted received signal. This reproduction of the original signal is accomplished by a process known as the demodulation or detection. Demodulation is the reverse process of modulation carried out in transmitter.

**Output transducer**

- Output transducer convert an electrical message signal into its original form.

- Example- loudspeaker which works as a transducer i.e. converts the electrical signal in the form of original sound signal.

### **3.2 Concept of Modulation and Demodulation, Difference between them**

- Modulation is the process by which some characteristics or parameters of the carrier wave is changed according to the signal containing information. These characteristics can be amplitude, frequency or phase. Basically, it is assumed that the information signal is a low-frequency one and thus needs conversion from low to high in order to have a better transmission.
- Demodulation is defined as extracting the original information-carrying signal from a modulated carrier wave. A demodulator is an electronic circuit that is mainly used to recover the information content from the modulated carrier wave.

#### **Need for modulation:**

- The baseband signals can be transmitted directly, but the baseband transmission has many limitations which can be overcome using modulation.
- In the process of modulation, the baseband signal is translated i.e. shifted from low frequency to high frequency.
- This frequency shift is proportional to the frequency of carrier.
- The modulation process has the following advantages:

#### **Advantages of modulation:**

##### **- Reduction in the height of antenna:**

- When the transmission occurs over free space, the antennae radiate the signal out and receiver receives it. In order to operate efficiently, antennae need to be in order of the magnitude of wavelength of the transmitted signal.
- For the transmission of radio signals, the antenna height must be a multiple of  $(\lambda/4)$ . Here  $\lambda$  is the wavelength.  $\lambda = c/f$  where  $c$  is velocity of light and  $f$  is the frequency of the signal to be transmitted.



- The minimum antenna height required to transmit a baseband signal of  $f=10$  kHz is calculated as follows:

Minimum antenna height =  $\lambda/4 = c/4f = (3 \times 10^8) / (4 \times 10 \times 10^3) = 7500$  meters i.e. 7.5 km

It is impossible to build antennae this big.

- Now consider a modulated signal at  $f=1$  MHz. The minimum antenna height is given by,

Minimum antenna height =  $\lambda/4 = c/4f = (3 \times 10^8) / (4 \times 1 \times 10^6) = 75$  meter

- This length of the antenna can be built easily and this example clearly shows us how hugely the process of modulation is enabling communication systems.

#### **-Avoids mixing of signals:**

- If the baseband sound signals are transmitted without using the modulation by more than one transmitter, then all the signals will be in the same frequency range i.e 0 to 20Khz. Therefore, all the signals get mixed together and a receiver cannot separate them from each other.
- Hence, if each baseband sound signal is used to modulate a different carrier then they will occupy different slots in the frequency domain (different channels). Thus, modulation avoids mixing of signals.

#### **-Increase the range of communication:**

- By using modulation to transmit the signals through space to long distances, it removed the need for wires in the communication systems.
- The technique of modulation helped to use wireless equipment in a big way in their lives.

#### **-Multiplexing is possible:**

- Multiplexing is a process in which two or more signals can be transmitted over the same communication channel simultaneously. This is possible only with modulation.
- The Multiplexing allows the same channel to be used by many signals.

#### **-Improves quality of reception:**

- With frequency modulation (FM), and the digital communication techniques like PCM, the effect of noise is reduced to a great extent. This improves quality of reception.

#### **Differences between Modulation and Demodulation**

1. The key difference between modulation and demodulation is that modulation is done at the transmitter side while demodulation is done at the receiver side of a communication system.
2. Both modulation and demodulation occur during data transmission but the two processes are exactly reverse of each other. In modulation original message signal is mixed with the carrier wave whose parameters are required to be changed. As against, in demodulation the combination of carrier and message signal are separated from each other, to have original information signal.
3. Modulation requires a modulator section for mixing of the two signals whereas demodulation requires demodulator to recover the original signal. However, combined equipment is used for the two known as Modem.
4. Modulation is done to convert the low-frequency signal into a high-frequency signal. While at the time of demodulation, the low-frequency signal is achieved from high-frequency signal.
5. Modulation is basically done to transmit data to longer distance whereas demodulation is done to regain the original message signal.
6. Demodulation is somewhat a complex process when compared with modulation.

### **3.3 Different types of Modulation (AM, FM & PM) based on signal, carrier wave and modulated wave (only concept, No mathematical Derivation)**

There are three types of modulation, namely:

#### **1. Amplitude modulation (AM)**

In **amplitude modulation**, the amplitude of the carrier wave is varied in proportion to the message signal, and the other factors like frequency and phase remain constant.

# CHAPTER-4

---

## 4. TRANSDUCERS AND MEASURING INSTRUMENTS

### 4.1 Concept of Transducer and sensor with their differences

#### Transducer

- The transducer is a device that changes the physical attributes of the non-electrical signal into an electrical signal which is easily measurable.
- The process of energy conversion in the transducer is known as the transduction.
- The transduction is completed into two steps. First by sensing the signal and then strengthening it for further processing.

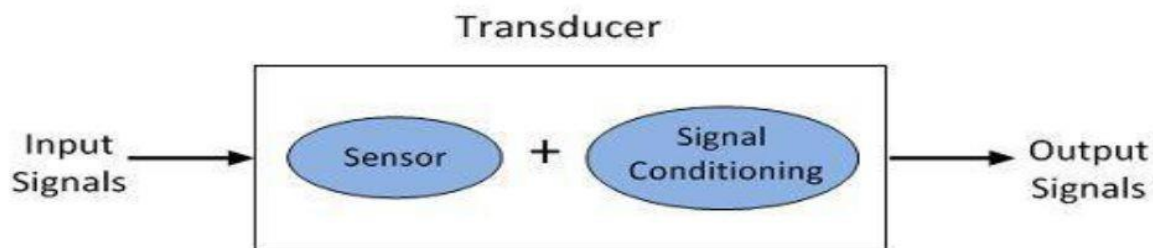

- The transducer has three major components; they are the input device, signal conditioning or processing device and an output device.
- The input devices receive the measurand quantity and transfer the proportional analogue signal to the conditioning device. The conditioning device modified, filtered, or attenuates the signal which is easily acceptable by the output devices.

#### Sensor

- The sensor is a device that measures the physical quantity (i.e. Heat, light, sound, etc.) into an easily readable signal (voltage, current etc.). It gives accurate readings after calibration.
- **Ex** – The mercury used in the thermometer converts the measured temperature into an expansion and contraction of the liquid which is easily measured with the help of a

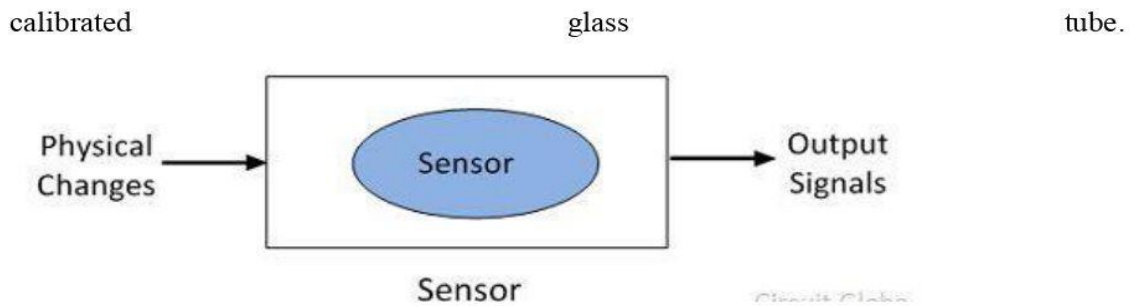

#### **Differences between Sensor and Transducer**

The following are the key differences between the sensor and transducer.

1. The sensor senses the physical change across the surrounding whereas the transducer transforms the one form of energy into another.
2. The sensor itself is the major component of the sensor, whereas the sensor and the signal conditioning are the major elements of the transducer.
3. The primary function of the sensor is to sense the physical changes, whereas the transducer converts the physical quantities into an electrical signal.
4. The accelerometer, barometer, gyroscope are the examples of the sensors whereas the thermistor, and thermocouple is the examples of the transducer.

#### **4.2 Different type of Transducers & concept of active and passive transducer.**

##### **Classification of Transducers**

The classification of transducers is made from the following basis:

1. Based on the physical phenomenon
  - Primary transducer
  - Secondary transducer
2. Based on the power type Classification
  - Active transducer
  - Passive transducer

3. Based on the type of output the classification of transducers are made

- Analog transducer
- Digital transducer

4. Based on the electrical phenomenon is a best Classification of Transducer

- Resistive transducer
- Capacitive transducer
- Inductive transducer
- Photoelectric transducer
- Photovoltaic transducer

5. Based on the non-electrical phenomenon Classification of transducer

- Linear displacement
- Rotary displacement

6. Based on the transduction phenomenon

- Transducer
- Inverse transducer.

**concept of active and passive transducer.**

#### **Active Transducer**

- The transducer which does not require the external power source is known as the active transducer.
- Such type of transducer develops their own voltage or current, hence known as a self-generating transducer.
- The energy required for generating the output signals are obtained from the physical quantity which is to be measured.



**Example:**

The Piezo electrical crystal is the example of the natural active transducer. The crystal has the property of producing the output voltage when the external force applied to them. The piezoelectric crystal is placed between the two metallic electrodes. When the force applied to the crystal, the voltage induces across it.

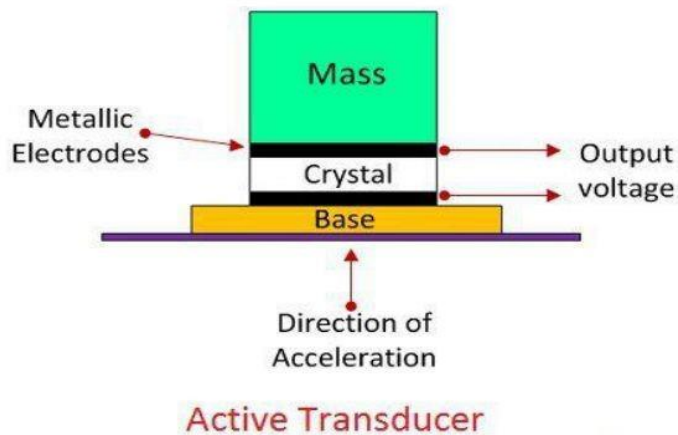
**Passive Transducer**

- The transducer which requires the power from an external supply source is known as the passive transducer.
- They are also known as the external power transducer. The capacitive, resistive and inductive transducers are the example of the passive transducer.
- **The passive transducer takes power from the external energy source for transduction.** The word transduction means conversion of energy from one form to another.

**Example:**

The linear potentiometer is the examples of the passive transducer. It is used for measuring the displacement. The POT requires the external power source  $e_i$  for work. It measures the linear displacement  $x_i$ .

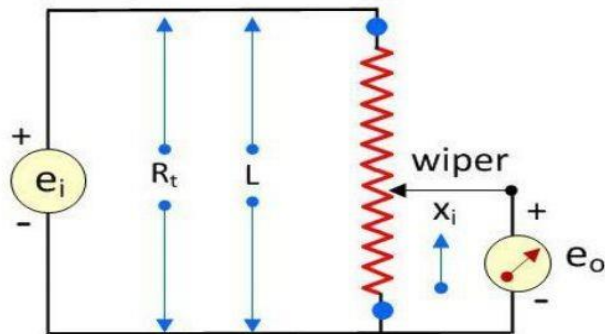

Linear Potentiometer (Pot), a passive transducer

Consider the  $L$  is the length of the potentiometer.  $R_i$  is their total internal resistance and  $x_i$  is their input displacement. The output voltage is calculated by the formula shown below.

$$e_o = \frac{x_i}{L} e_i$$

Or

$$x_i = \left( \frac{e_o}{e_i} \right) L$$

### 4.3 Working principle of photo emissive, photoconductive, photovoltaic transducer and its application

The photoelectric transducer converts the light energy into electrical energy. It is made of semiconductor material. The photoelectric transducer uses a photosensitive element, which ejects the electrons when the beam of light absorbs through it.

These photoelectric transducers are classified into five types which include the following

- Photo emissive Cell
- Photodiode

- Phototransistor
- Photo-voltaic cell
- Photoconductive Cell

#### Photo-emissive Cell

- The Photo-emissive cell converts the photons into electric energy. It consists the anode and the cathode plate. The anode and cathode are coated with Photo-emissive material called caesium antimony.

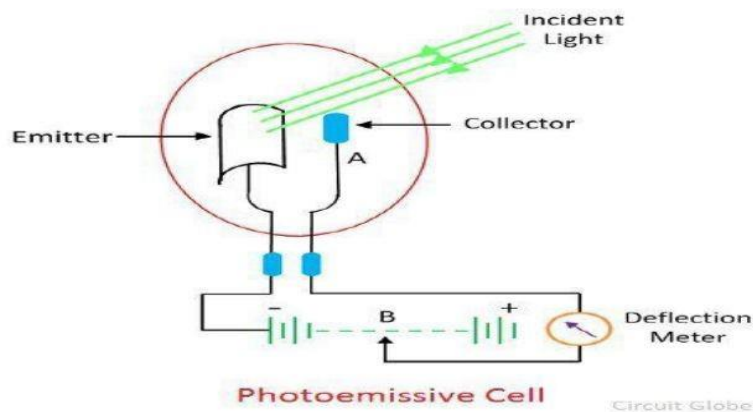

- When the radiation of light fall on cathode plates the electrons starts flowing from anode to cathode. Both the anode and the cathode are sealed in a closed, opaque evacuated tube. When the radiation of light falls on the sealed tube, the electrons starts emitting from the cathode and moves towards the anode.
- The anode is kept to the positive potential. Thus, the photoelectric current starts flowing through the anode. The magnitude of the current is directly proportional to the intensity of light passes through it.

#### Photoconductive Cell

- The photoconductive cell converts the light energy into an electric current. It uses the semiconductor material like cadmium selenide, Ge, Se, as a photo sensing element.

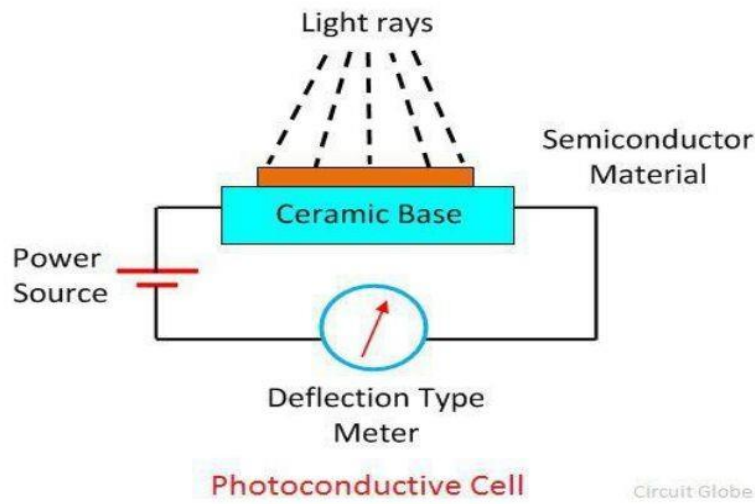

- When the beam of light falls on the semiconductor material, their conductivity increases and the material works like a closed switch. The current starts flowing into the material and deflects the pointer of the meter.

#### **Photo-voltaic cell**

- The photovoltaic cell is the type of active transducer. The current starts flowing into the photovoltaic cell when the load is connected to it. The silicon and selenium are used as a semiconductor material. When the semiconductor material absorbs heat, the free electrons of the material start moving. This phenomenon is known as the photovoltaic effect.
- The movements of electrons develop the current in the cell, and the current is known as the photoelectric current.

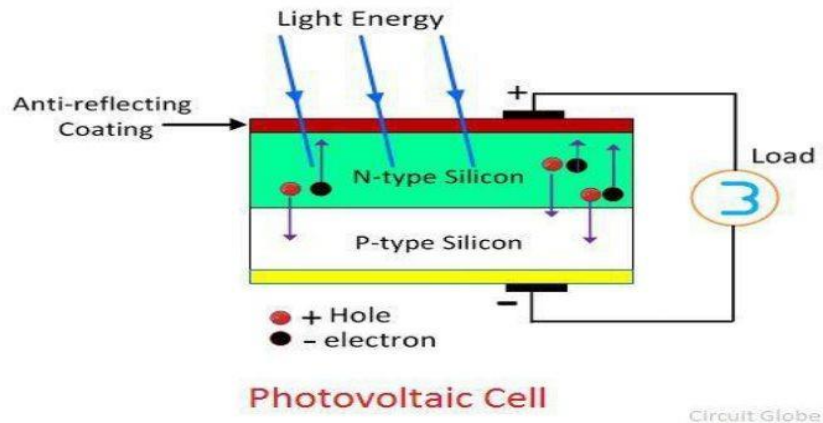

### Applications of Photoelectric Transducer

The applications of this transducer mainly include the following.

- These transducers are used in biomedical applications
- Pickups of pulse
- Pneumograph respiration
- Measure blood pulsatile volume changes
- Records Body movements.

### 4.4 Multimeter and its applications

- A multimeter is an electronic measuring instrument that combines several measurement functions in one unit.
- A typical multimeter can measure voltage, current, and resistance. It is an indispensable instrument and can be used for measuring d.c as well as a.c voltages and currents.
- Multimeter is the most inexpensive equipment and can make various electrical measurement with reasonable accuracy.



## Applications

- For checking the circuit continuity.
- For measuring d.c current flowing through the cathode, plate,screen and other vacuum tube circuits.
- For measuring d.c voltages across various resistors in electric circuits.
- For measuring a.c voltages across power supply transformers.
- For ascertaining whether or not open or short circuit exists in the circuit under study.

## 4.5 Analog and Digital Multimeter and their differences

### Analog Multimeter

- Analog Multimeter is basically a moving coil instrument. A rectifier unit is also provided with the instrument. It is a multirange instrument and various ranges are obtained by different resistance elements in series or in parallel with the movement of the instrument. With the help of a rotary selector switch the various ranges are used.

### Digital Multimeter

- The digital multimeter is an instrument capable of measuring dc voltage, ac voltage, dc current, ac current, resistance, conductance and decibels. Thus DMM offers increased versatility. Some DMMs can measure the temperature, frequency etc.
- A DMM has a digital display and a function selector switch. The range selection takes place automatically. There are four input terminals, out of which two terminals are used for measurement of all the general purpose quantities such as ac/dc voltage, resistance, capacitance and diode, transistor testing.

### Difference between Analog and Digital Multimeter

Analog Multimeter	Digital Multimeter
Power supply is not required	Power supply is required

Visual indication of changes in the reading is not that much better	Better visual indication of changes in the reading is obtained
Less suffered from electrical noise	More suffered from electrical noise
Less isolation problems.	More isolation problems.
Accuracy is less	High accuracy is obtained.
The output cannot be interfaced with external equipment	The output can be interfaced with external equipment
Construction is simple	Construction is complicate
Bigger in size	Smaller in size
Many times output is ambiguous	An unambiguous reading is obtained
Less expensive	More expensive

**4.6 Working principle of Multimeter with Basic Block diagram**

- All digital multimeters make use of some type of analog to digital converter (ADC). Generally dual slope integration type AD is used for this purpose. The block diagram of basic digital multimeter is as shown in figure below

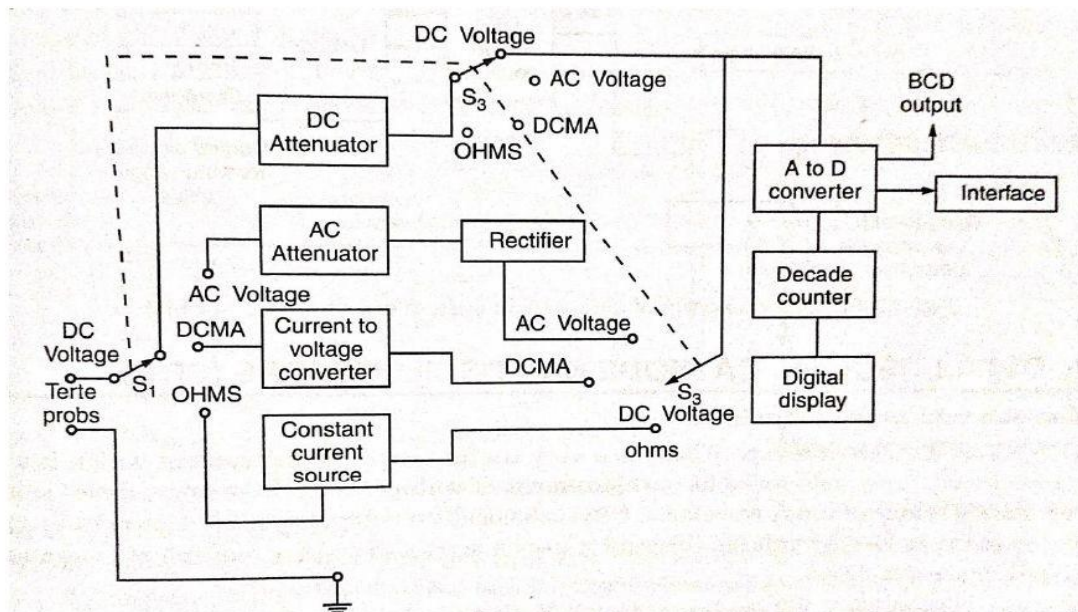

- A commercial digital multimeter consist of several A to D converters, decade counters and display. It is basically dc voltmeter. In order to measure unknown current; current to

voltage converter is used. An unknown current to be measured is applied to one of the input terminals of op-amp. Since input impedance of op-amp is very high; very small current can pass through it. This current passing into the op-amp can be neglected.

- Thus  $I_m = I_{fb}$ , Here  $I_{fb}$  = feedback current
- This feedback current is allowed to pass through one of the known resistances. This current will cause a voltage drop across the resistance. This voltage is applied to analog to digital converter and finally digital display is obtained. Thus, output displayed on the digital display is directly proportional to unknown current.
- In order to measure an unknown resistance; a constant current source is used. The current from this constant current source is allowed to pass through unknown resistance. Thus the proportional voltage is obtained. The output display is directly proportional to unknown resistance.
- To measure the ac voltage; a rectifier and filter is used. This rectifier converts ac signal into dc signal. Now, this dc signal is applied to A to D converter to the digital display. The BCD output can be obtained from A to D converter. Similarly, the output from digital multimeter can be used to interface with other equipments.

#### **4.7 CRO, working principle of CRO with simple Block diagram**

- Oscilloscope is electronic equipment, which displays a voltage waveform. Among the oscilloscopes, Cathode Ray Oscilloscope (CRO) is the basic one and it displays a time varying signal or waveform.

##### **Block Diagram of CRO**

- Cathode Ray Oscilloscope (CRO) consists a set of blocks. Those are vertical amplifier, delay line, trigger circuit, time base generator, horizontal amplifier, Cathode Ray Tube (CRT) & power supply. The block diagram of CRO is shown in below figure.

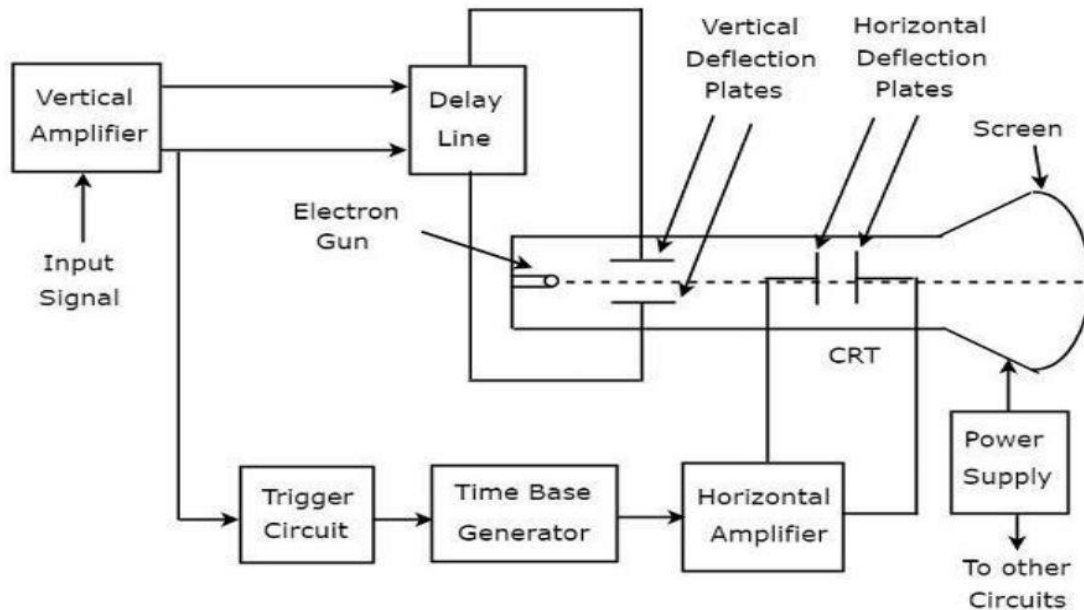

The function of each block of CRO is mentioned below.

- **Vertical Amplifier** – It amplifies the input signal, which is to be displayed on the screen of CRT.
- **Delay Line** – It provides some amount of delay to the signal, which is obtained at the output of vertical amplifier. This delayed signal is then applied to vertical deflection plates of CRT.
- **Trigger Circuit** – It produces a triggering signal in order to synchronize both horizontal and vertical deflections of electron beam.
- **Time base Generator** – It produces a sawtooth signal, which is useful for horizontal deflection of electron beam.
- **Horizontal Amplifier** – It amplifies the sawtooth signal and then connects it to the horizontal deflection plates of CRT.
- **Power supply** – It produces both high and low voltages. The negative high voltage and positive low voltage are applied to CRT and other circuits respectively.