



**KIIT POLYTECHNIC**

**LECTURE NOTES  
ON  
ENGINEERING PHYSICS (Th -2a)**

**Prepared by**

**Sradhanjali Das, Lecturer Physics  
Department of Basic Sciences and Humanities  
Email Id:sradhanjalifpy@kp.kiit.ac.in**

**CONTENTS**

<b>Sl.No</b>	<b>Chapter Name</b>	<b>Page No</b>
1	UNITS & DIMENSIONS	1-6
2	SCALARS & VECTORS	7-14
3	KINEMATICS	15-22
4	WORK & FRICTION	23-25
5	GRAVITATION	26-32
6	OSCILLATION & WAVES	33-38
7	HEAT & THERMODYNAMICS	39-47
8	OPTICS	48-52
9	ELECTROSTATICS & MAGNETOSTATICS	53-62
10	CURRENT ELECTRICITY	63-71
11	ELECTROMAGNETISM &ELECTROMAGNETIC INDUCTION	72-74
12	MODERN PHYSICS	75-79

## CHAPTER -1

### UNITS & DIMENSIONS

#### Physical quantities:

The quantities which can be measured and in terms of which the laws of Physics are expressed are called Physical quantities.

#### Fundamental Units:

The physical quantities like mass, length and time which can be defined independently are known as fundamental or base quantities.

There are seven fundamental quantities

- i) Mass – M
- ii) Length – L
- iii) Time – T
- iv) Temperature – K or  $\theta$
- v) Electric current – A or I
- vi) Luminous Intensity – Cd (candela)
- vii) Amount of substance - Mole

#### Derived Quantities:

The physical quantities which can be derived by using the fundamental quantities are known as derived quantities.

Ex: velocity, Force, Momentum, work etc.

#### System of Units:

1. **C.G.S System** (Centimetre-Gram-Second) / French System: It is a system of units in which length, mass and time are taken as 1 centimetre, 1 gram and 1 second respectively.
2. **M.K.S System** (Metre-Kilogram-Second) / Metric System: It is a system of units in which length, mass and time are taken as 1 metre, 1 kilogram and 1 second

respectively.

3. **F.P.S System** (Foot-Pound-Second) / British System: It is a system of units in which length, mass and time are taken as 1 foot, 1 pound and 1 second respectively.
4. **S.I. System**: It is a system of international standard in which there are seven fundamental and two supplementary units.

### **Fundamental Units:**

- Mass – Kilogram
- Length- metre
- Time- second
- Electric current- Ampere
- Temperature- Kelvin
- Luminous Intensity—Candela
- Amount of substance- Mole

### **Supplementary Units:**

- Angle – radian • Solid angle - steradian

### **Dimensions:**

The dimensions of a physical quantity are the powers of the fundamental quantities to express that physical quantity.

### **Dimensional Formula:**

The dimensional formula of a physical quantity is the formula or expression in terms of the fundamental quantities to express that physical quantity.

<b>Sl. No</b>	<b>Quantities</b>	<b>Dimensional formula</b>	<b>S.I. Units</b>
1	Velocity	$\frac{\text{Displacement}}{\text{Time}} = \frac{L}{T} = [LT^{-1}]$	

		The dimensional formula of velocity is $[LT^{-1}]$ The dimensions of velocity are (1, -1) of length and time respectively.	m/sec
2	Acceleration	$\frac{Velocity}{Time} = \frac{LT^{-1}}{T} = [LT^{-1}]$	m/sec <sup>2</sup>
3	Force	Mass x Acceleration = $M \times LT^{-2} = [MLT^{-2}]$	Newton
4	Momentum	Mass x velocity = $M \times LT^{-1} = [MLT^{-1}]$	kg m/sec
5	Impulse	Force x Time = $MLT^{-2} \times T = [MLT^{-1}]$	Newton.Sec
6	Pressure	$\frac{Force}{Area} = \frac{MLT^{-2}}{L^2} = [M^1L^{-1}T^{-2}]$	N/m <sup>2</sup>
7	Density	$\frac{Mass}{Volume} = \frac{M}{L^3} = [ML^{-3}]$	Kg/m <sup>3</sup>
8	Work	Force x Displacement = $MLT^{-2} \times L = [ML^2T^{-2}]$	Joule
9	Kinetic energy	$\frac{1}{2}mv^2 = M \times [LT^{-1}]^2 = [M^1L^2T^{-2}]$	Joule
10	Potential energy	$mgh = M \times LT^{-2} \times L = [M^1L^2T^{-2}]$	Joule
11	Power	$\frac{Work}{Time} = \frac{M^1L^2T^{-2}}{T} = [M^1L^2T^{-3}]$	Watt
12	Frequency	$\frac{1}{Time} = \frac{1}{Time} = [M^0L^0T^{-1}]$	(Sec) <sup>-1</sup> = Hertz
13	Gravitational Constant (G)	$\frac{Fr^2}{M_1M_2} = \frac{MLT^{-2} \cdot L^2}{M^2} = [M^{-1}L^3T^{-2}]$	N.m <sup>2</sup> / Kg <sup>2</sup>
14	Angle	$\frac{Arc}{Radius} = \frac{L}{L} = [M^0L^0T^0]$ (Dimensionless quantity)	radian
15	Angular Velocity	$\frac{AngularDisplacement}{Time} = \frac{M^0L^0T^0}{T} = [M^0L^0T^{-1}]$	radian/sec
16	Angular acceleration	$\frac{AngularVelocity}{Time} = \frac{M^0L^0T^{-1}}{T} = [M^0L^0T^{-2}]$	radian/sec <sup>2</sup>
17	Coefficient of friction		No Unit

		$\frac{\text{Force of friction}}{\text{Normal reaction}} = \frac{MLT^{-2}}{MLT^{-2}} = [M^0 L^0 T^0]$ (dimensionless)	
18	Relative Density	$\frac{\text{Density of the Body}}{\text{Density of water}} = \frac{ML^{-3}}{ML^{-3}} = [M^0 L^0 T^0]$	No Unit
19	Specific heat	$\frac{\text{Amount of heat}}{\text{Mass} \times \text{Change in temp}} = \frac{M^1 L^2 T^{-2}}{M \times K} = [M^0 L^2 T^{-2} K^{-1}]$	Kcal/Kg °C
20	Electric field	$\frac{\text{Force}}{\text{Charge}} = \frac{MLT^{-2}}{AT} = [MLT^{-3} A^{-1}]$	N / Coulomb

### Principle of Homogeneity:

The principle of homogeneity states that the dimensional formula of every term in both sides of a correct relation must be same.

### Uses of Dimensions:

1. To convert the values of a physical quantity from one system to another.
2. To check the correctness of a given relation.
3. To derive a relation between various physical quantities.

### Q. Check the correctness of the following equation by using dimensional method.

- i)  $v = u + at$
- ii)  $S = ut + \frac{1}{2} at^2$
- iii)  $v^2 - u^2 = 2aS$

**Ans. i)  $v = u + at$**

Dimensional formula of  $V = [LT^{-1}]$

Dimensional formula of  $u = [LT^{-1}]$

Dimensional formula of  $at = [LT^{-2}][T] = [LT^{-1}]$

Since, the dimensional formula of all the three terms are same, the equation is dimensionally correct.

$$\text{ii) } \mathbf{S = ut + \frac{1}{2} at^2}$$

Dimensional formula of  $S = [L]$

Dimensional formula of  $ut = [LT^{-1}][T] = [L]$

Dimensional formula of  $\frac{1}{2} at^2 = [LT^{-2}][T^2] = [L]$

Since, the dimensional formula of all the terms in the above equation are same, the equation is dimensionally correct.

$$\text{iii) } \mathbf{v^2 - u^2 = 2aS}$$

Dimensional formula of  $v^2 = [LT^{-1}]^2 = [L^2 T^{-2}]$

Dimensional formula of  $u^2 = [LT^{-1}]^2 = [L^2 T^{-2}]$

Dimensional formula of  $2aS = [LT^{-2}][L] = [L^2 T^{-2}]$

Since, the dimensional formula of all the terms in the above equation are same, the equation is dimensionally correct.

**The time period (T) of a simple pendulum depend upon the lenth (L) and acceleration due to gravity (g) dimensional method derive the expression for the time period (T)**

A: Let,  $T \propto L^x$

$$\propto g^y$$

combining these two equation,  $T \propto L^x g^y$

$$\Rightarrow T = KL^x g^y \quad (\text{K is a Dimensionless constant})$$

Now, writing the dimensional formula of both the side

$$[M^0 L^0 T^1] = [L]^x [L^2 T^{-2}]^y$$

$$\Rightarrow [M^0 L^0 T^1] = [L^{x+y} T^{-2y}]$$

Now using the principle of homogeneity

$$x + y = 0 \quad \text{and} \quad -2y = 1 \Rightarrow y = -\frac{1}{2} \quad \Rightarrow x = \frac{1}{2}$$

Thus the equation,  $T = KL^x g^y$  becomes

$$T = KL^{1/2} g^{1/2}$$

$$\Rightarrow T = K \sqrt{\frac{L}{g}}$$

**Q. The centripetal force (F) depends upon mass of the particle (m), velocity (v) and radius(r) of the circular path. Using dimensional method derive the expression for the this force.**

A Let,  $F \propto m^a$

$$\propto r^b$$

$$\propto v^c$$

combining,  $F \propto m^a r^b v^c$

$$F = K m^a r^b v^c$$

Writing the dimension formula ,

$$[M^1 L^1 T^{-2}] = [M]^a [r]^b [LT^{-1}]^c$$

$$[M^1 L^1 T^{-2}] = M^a r^{b+c} T^{-c}$$

Using the principle of homogeneity

$$a = 1, \quad b+c = 1, \quad -c = -2, \quad b = -1 \Rightarrow c = 2$$

The equation becomes,  $F = K m^a r^b v^c$

$$\text{So, } F = K m r^{-1} v^2$$

$$F = K \frac{mv^2}{r}$$

**Q. Using dimensional method check the correctness of the following equations.**

$$i) \quad g = \frac{GM}{R^2} \quad ii) \quad T = 2\pi \sqrt{\frac{L}{g}} \quad iii) \quad F = \frac{mv^2}{r}$$



## UNIT- 2

### (SCALAR & VECTOR)

#### Scalar quantities:

The physical quantities having only magnitudes are known as scalar quantities.

Ex. Mass, Length, Volume, Temperature, Electrical Charge etc.

#### Vector quantities:

The physical quantities having both magnitudes and directions are known as vector quantities.

Ex. Displacement, Velocity, Acceleration, Force, Momentum etc.

A vector quantity is always represented by a line segment with an arrow head ( $\vec{A}$ )

#### Types of Vectors:

- Equal Vector:

The vectors are said to be equal if they have the same magnitude and direction.

- Negative vector:

A vector is said to be negative of other vector if they are equal in magnitude and opposite in direction.

- Unit Vector:

A unit vector of a vector is that whose magnitude is 1 unit and its direction is along the original vector.

$$\hat{A} = \frac{\vec{A}}{|\vec{A}|}$$

$$\vec{A} = \hat{A} |\vec{A}| \quad \Rightarrow$$

- Co-linear Vector:
  - i) Parallel vector: Two vectors acting along same direction are called parallel vectors angle between two vectors is  $0^\circ$ .
  - ii) Anti parallel vector: Two vectors which are directed in opposite directions are called anti parallel vectors. Angle between two vectors is  $180^\circ$ .

- Co-planar Vector:

Vectors situated in one plane irrespective of their directions are known as co-planar vector.

- Orthogonal Vector:

Two vectors are said to be orthogonal if they are perpendicular to each other. Angle between two vectors is  $90^\circ$ .

- Orthogonal unit vector:

The vectors whose magnitudes are one unit each and orthogonal to each other are called orthogonal unit vectors.

$\hat{i}$ ,  $\hat{j}$  and  $\hat{k}$  are the unit vectors along X – axis, Y-axis and Z-axis respectively.

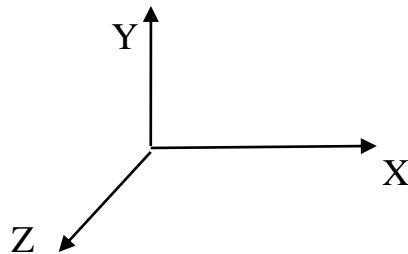

### Triangle law of vector addition:

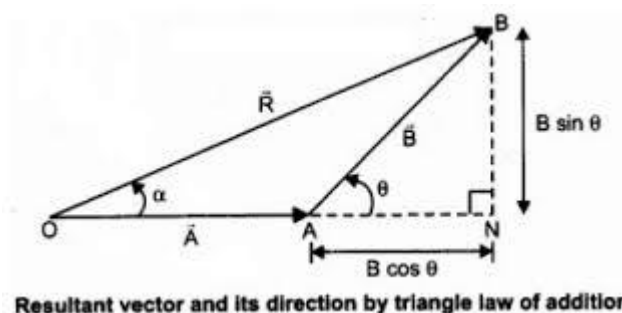

If two vectors are represented by the two sides of a triangle, taken in the same order then the resultant vector is represented by the third side of the triangle in opposite order.

Magnitude of the Resultant Vector

$$R = \sqrt{A^2 + B^2 + 2AB\cos\theta}$$

The direction of the Resultant Vector

$$\beta = \tan^{-1} \frac{B\sin\theta}{A+B\cos\theta}$$

### Parallelogram law of vector addition:

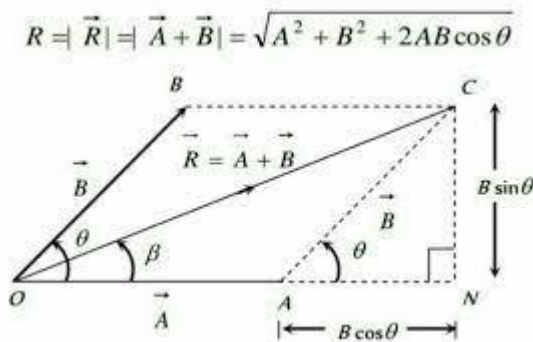

The parallelogram law of vector addition states that if two vectors are represented by the adjacent sides of the parallelogram taken in the same order then the resultant vector is represented by the diagonal passing through the common point taken in opposite order.

Magnitude of the Resultant Vector

$$R = \sqrt{A^2 + B^2 + 2AB\cos\theta}$$

The direction of the Resultant Vector

$$\beta = \tan^{-1} \frac{B \sin \theta}{A + B \cos \theta}$$

### Special Cases:

I ) When the vectors acting along the same direction

$$\text{i.e } \theta = 0^\circ, \cos \theta = 1, \sin \theta = 0$$

$$\text{So, } R = A + B \text{ (Maximum) } \& \beta = 0^\circ$$

II ) When the vectors are perpendicular

$$\text{i.e } \theta = 90^\circ, \cos \theta = 0, \sin \theta = 1$$

$$\text{So, } R = \sqrt{A^2 + B^2} \& \beta = \tan^{-1} \left( \frac{B}{A} \right)$$

III ) When the vectors are acting in opposite direction

$$\text{i.e } \theta = 180^\circ, \cos \theta = -1, \sin \theta = 0$$

$$\text{So, } R = A - B \text{ (Minimum) } \& \beta = 0^\circ$$

**Q .If the magnitude of resultant of two forces is equal to the magnitude of either of them. Find the angle between them .**

Ans. Given that  $R = A = B$

$$\text{So } R = \sqrt{A^2 + B^2 + 2AB \cos \theta}$$

$$A^2 = A^2 + A^2 + 2 A^2 \cos \theta$$

$$A^2 = 2A^2 + 2 A^2 \cos \theta$$

$$A^2 = 2A^2 ( 1 + \cos \theta )$$

$$\Rightarrow ( 1 + \cos \theta ) = 1 / 2$$

$$\Rightarrow \cos \theta = -\frac{1}{2}$$

$$\Rightarrow \theta = 120^\circ$$

**Q .The magnitude of resultant of two forces ( A + B ) and ( A – B ) is  $\sqrt{(3A^2 + B^2)}$ . Find the angle between them .**

Ans : Given that P = ( A + B ) , Q = ( A – B ) , R =  $\sqrt{(3A^2 + B^2)}$

Since R =  $\sqrt{P^2 + Q^2 + 2PQCOS\theta}$

$$\sqrt{(3A^2 + B^2)} = \sqrt{(A + B)^2 + (A - B)^2 + 2(A + B)(A - B)\cos\theta}$$

$$3A^2 + B^2 = 2A^2 + 2B^2 + 2(A^2 - B^2)\cos\theta$$

$$A^2 - B^2 = 2(A^2 - B^2)\cos\theta$$

$$\Rightarrow \cos\theta = \frac{1}{2}$$

$$\Rightarrow \theta = 60^\circ$$

### **Resolution of a vector :**

It means splitting of a vector into its components which when added gives the original vector.

$$\vec{A} = A_x \hat{i} + A_y \hat{j}$$

here,

$$\cos\theta = \frac{A_x}{A} ,$$

$$\sin\theta = \frac{A_y}{A}$$

$$A_x = A \cos\theta$$

$$A_y = A \sin\theta$$

$$\boxed{A = \sqrt{A_x^2 + A_y^2}}$$

$$\vec{A} = A_x \hat{i} + A_y \hat{j} + A_z \hat{k}$$

$$A = \sqrt{A_x^2 + A_y^2 + A_z^2}$$

**Q. One component of a force making an angle  $60^\circ$  with horizontal is 20 N. Find the other component.**

Ans. One component

$$F_x = F \cos \theta \quad \Rightarrow \quad 20 = F \cos \theta$$

$$\Rightarrow 20 = \frac{F}{2} \quad \Rightarrow \quad F = 40 \text{ N}$$

So another component

$$F_y = F \sin \theta = 40 \sin 60^\circ = 40 \times \frac{\sqrt{3}}{2}$$

$$F_y = 20\sqrt{3} \text{ N}$$

**Q. One component of a force 65 N is 25 N, then find the other component.**

Ans Since,  $F = \sqrt{F_x^2 + F_y^2} \quad \Rightarrow \quad (65)^2 = (25)^2 + F_y^2$

$$\Rightarrow \quad F_y^2 = 4225 - 625 = 3600 \quad \Rightarrow \quad F_y = 60 \text{ N}$$

### **Dot product of the vectors (scalar product) :**

- The dot product of two vectors is defined as the product of their magnitude and the cosine of the angle between them. i.e  $\vec{A} \cdot \vec{B} = AB \cos \theta$
- The dot product of two vectors is always a scalar quantity.
- Example:  $W = \vec{F} \cdot \vec{S} = FS \cos \theta$
- If  $\theta = 0^\circ$ ,  $\vec{A} \cdot \vec{B} = AB$
- If  $\theta = 90^\circ$ ,  $\vec{A} \cdot \vec{B} = 0$
- If  $\theta = 180^\circ$ ,  $\vec{A} \cdot \vec{B} = -AB$
- The dot product is commutative in nature i.e  $\vec{A} \cdot \vec{B} = \vec{B} \cdot \vec{A}$
- The dot product is distributive in nature i.e  $\vec{A} \cdot (\vec{B} + \vec{C}) = \vec{A} \cdot \vec{B} + \vec{A} \cdot \vec{C}$

- Unit vectors of dot product

$$\hat{i} \cdot \hat{i} = \hat{j} \cdot \hat{j} = \hat{k} \cdot \hat{k} = 1$$

$$\hat{i} \cdot \hat{j} = \hat{j} \cdot \hat{k} = \hat{k} \cdot \hat{i} = 0, \quad \hat{j} \cdot \hat{i} = \hat{k} \cdot \hat{j} = \hat{i} \cdot \hat{k} = 0$$

- Dot product in terms of rectangular components

$$\vec{A} = A_x \hat{i} + A_y \hat{j} + A_z \hat{k} \quad \& \quad \vec{B} = B_x \hat{i} + B_y \hat{j} + B_z \hat{k}$$

$$\vec{A} \cdot \vec{B} = (A_x \hat{i} + A_y \hat{j} + A_z \hat{k}) \cdot (B_x \hat{i} + B_y \hat{j} + B_z \hat{k})$$

$$\vec{A} \cdot \vec{B} = A_x B_x + A_y B_y + A_z B_z$$

- $\vec{A} \cdot \vec{B} = AB \cos \theta, \quad \cos \theta = \frac{\vec{A} \cdot \vec{B}}{AB}$

### Cross product of the vectors (vector product) :

- The cross product of two vectors is defined as the product of their magnitude, the sine of the angle between them and the direction is perpendicular to the plane containing the vectors. i.e  $\vec{A} \times \vec{B} = AB \sin \theta \hat{n}$

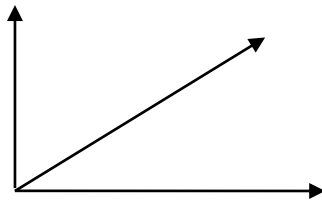

- The dot product of two vectors is always a scalar quantity.
- Example:  $\vec{L} = \vec{r} \times \vec{p}$
- If  $\theta = 0^\circ, \vec{A} \times \vec{B} = 0$
- If  $\theta = 90^\circ, \vec{A} \times \vec{B} = 1$
- If  $\theta = 180^\circ, \vec{A} \times \vec{B} = 0$
- The cross product is not commutative in nature i.e  $\vec{A} \times \vec{B} \neq \vec{B} \times \vec{A}$  &
- The cross product is distributive in nature i.e  $\vec{A} \times (\vec{B} + \vec{C}) = \vec{A} \times \vec{B} + \vec{A} \times \vec{C}$

**Unit vectors of cross product :**

$$\hat{i} \times \hat{i} = \hat{j} \times \hat{j} = \hat{k} \times \hat{k} = 0$$

$$\hat{i} \times \hat{j} = \hat{k} \quad \hat{j} \times \hat{k} = \hat{i} \quad \hat{k} \times \hat{i} = \hat{j}$$

$$\hat{j} \times \hat{i} = -\hat{k} \quad \hat{k} \times \hat{j} = -\hat{i} \quad \hat{i} \times \hat{k} = -\hat{j}$$

**Cross product in terms of rectangular components :**

$$\text{If } \vec{A} = A_x \hat{i} + A_y \hat{j} + A_z \hat{k} \quad \& \quad \vec{B} = B_x \hat{i} + B_y \hat{j} + B_z \hat{k}$$

$$\vec{A} \times \vec{B} = \begin{vmatrix} \hat{i} & \hat{j} & \hat{k} \\ A_x & A_y & A_z \\ B_x & B_y & B_z \end{vmatrix} = i (A_y B_z - A_z B_y) - j (A_x B_z - A_z B_x) + k (A_x B_y - A_y B_x)$$

Q If  $\vec{A} = 3\hat{i} - 2\hat{j} + \hat{k}$ , and  $\vec{B} = 5\hat{i} + 2\hat{j} - 3\hat{k}$  then find  $\vec{A} \cdot \vec{B}$ ?

Q If  $\vec{A} = 5\hat{i} - 2\hat{j} + 3\hat{k}$ ,  $\vec{B} = \hat{i} + 2\hat{j} - \hat{k}$  and  $\vec{C} = 3\hat{i} + 2\hat{k}$  then find  $\vec{A} \cdot (\vec{B} \times \vec{C})$

Q If  $\vec{A} \cdot \vec{B} = \sqrt{3} |\vec{A} \times \vec{B}|$  find the angle between two vectors.

Q If  $\vec{A} \cdot \vec{B} = |\vec{A} \times \vec{B}|$  find the angle between two vectors.

Q  $\vec{A} = 2\hat{i} - \hat{j} + 3\hat{k}$  and  $\vec{B} = \hat{i} + 5\hat{j} - 2\hat{k}$  find  $\vec{A} \cdot \vec{B}$  and  $\vec{A} \times \vec{B}$

Q Find the angle between two vectors  $(\hat{i} - 2\hat{j} - 5\hat{k})$  and  $(2\hat{i} + \hat{j} - 4\hat{k})$ .

Q  $\vec{F} = 5\hat{i} + 3\hat{j} - 2\hat{k}$  and  $\vec{S} = 4\hat{i} + 7\hat{j} + \hat{k}$  find the work done.

Q If  $\vec{A} = 6\hat{i} - n\hat{j} + 3\hat{k}$ ,  $\vec{B} = 5\hat{i} + 2\hat{j} - n\hat{k}$ , are orthogonal to each other then find the value of n.

Q  $\vec{A} = \hat{i} - \hat{j} + 3\hat{k}$  and  $\vec{B} = 5\hat{i} + 5\hat{j}$  Find  $\vec{A} \times \vec{B}$



## UNIT - 3

### KINEMATICS

#### Equations of motion

Let,  $u$  - Initial velocity

$v$  – Final velocity

$a$  - acceleration

$S$ - displacement

$t$  - Time period

- 1) Velocity after  $t$ - second,  $v = u + at$
  - 2) Displacement after  $t$  second,  $S = ut + \frac{1}{2} at^2$
  - 3) Velocity after a displacement  $S$ ,  $v^2 - u^2 = 2aS$
  - 4) Displacement during  $n$ th second,  $S_{nth} = u + a/2(2n-1)$
- \* When a body starts from rest,  $u=0$
  - \* When a body comes to rest  $v=0$
  - \* In vertically downward direction,  $a=g$ ,  $u=0$
  - \* In vertically upward direction,  $a=-g$ , at the highest point  $v=0$

**Q. The velocity of a body increases, at a constant rate, from  $10 \text{ ms}^{-1}$  to  $25 \text{ ms}^{-1}$  in 6 minute. Find the acceleration and the distance travelled.**

Ans: Given,  $u = 10 \text{ ms}^{-1}$  ,  $v = 25 \text{ ms}^{-1}$  ,  $t = 6 \text{ minute} = 360 \text{ Sec}$

Using the equation of motion,  $v = u + at$

$$a = \frac{v-u}{t} = \frac{25-10}{360} = \frac{15}{360} = \frac{1}{24} \text{ ms}^{-2}$$

Using,  $v^2 - u^2 = 2aS$

$$S = \frac{v^2 - u^2}{2a} = \frac{625 - 100}{2 \times 1/24} = 6300 \text{ m} = 6.3 \text{ Km}$$

**Q. A car moving with a velocity of  $30 \text{ ms}^{-1}$  is stopped by the application of brakes which impart a retardation of  $6 \text{ ms}^{-2}$  to the car. how long does it take for the car to come to a stop ? How far does the car travel during the time brakes are applied?**

Ans: Given,  $u = 30 \text{ ms}^{-1}$  ,  $v = 0$  ,  $a = -6 \text{ ms}^{-2}$

Using the equation of motion,  $v = u + at$

$$0 = 30 - 6t$$

$$6t = 30 , \text{ so } t = 5 \text{ Sec.}$$

Using, Using,  $v^2 - u^2 = 2aS$

$$S = \frac{v^2 - u^2}{2a} = \frac{0 - 900}{2 \times (-6)} = 75 \text{ m}$$

### **Projectile motion:**

A projectile is a body which is thrown with some initial velocity and as it moves no other energy is given to it. It moves under the action of gravity. The motion of the body is known as projectile motion.

\* The path followed by the projectiles is known as trajectory.

- Ex. 1) A bomb dropped from an aeroplane.  
 2) A bullet fired from a gun  
 3) A ball thrown into space.

### **Projectile fired making an angle $\theta$ with horizontal:**

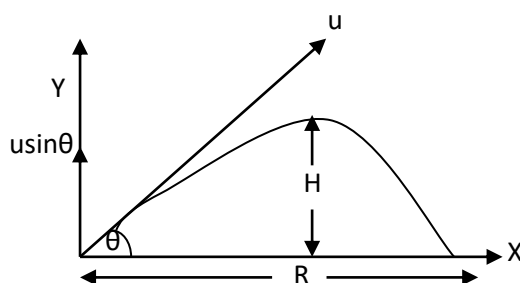

Consider a projectile fired making an angle  $\theta$  with horizontal, with a velocity  $u$ .

Resolving the velocity into 2 components.

- i)  $u \cos \theta$ , along horizontal direction
- ii)  $u \sin \theta$ , along vertical direction

it is non-uniform as the body moves. It gradually decreases and becomes zero at the height point P.

### **Equation of trajectory (path of the projectile) :**

It is a relation between the horizontal and vertical equation of motion of the projectile.

Horizontal equation of motion:

$$x = (u \cos \theta) t$$

$$\Rightarrow t = \frac{x}{u \cos \theta}$$

Vertical equation of motion

$$y = (u \sin \theta) t - \frac{1}{2} g t^2$$

$$\Rightarrow y = (u \sin \theta) \left( \frac{x}{u \cos \theta} \right) - \frac{1}{2} g \left( \frac{x}{u \cos \theta} \right)^2$$

$$\Rightarrow y = \frac{u \sin \theta x}{u \cos \theta} - \frac{1}{2} g \frac{x^2}{u^2 \cos^2 \theta}$$

$$\Rightarrow \boxed{y = \tan \theta x - \left( \frac{g}{2u^2 \cos^2 \theta} \right) x^2}$$

This equation represents a parabola. Thus, the path followed by a projected is parabolic in nature.

### **Maximum Height:**

It is the maximum distance covered by the projectile in vertical direction.

Consider the motion in vertically upward direction.

$$(u \sin \theta)^2 = 2(-g) H$$

$$\Rightarrow -u^2 \sin^2 \theta = -2gH$$

$$\Rightarrow \boxed{H = \frac{u^2 \sin^2 \theta}{2g}}$$

### **Time of ascent:**

It is the time taken by the projectile to reach at the highest point from the point of projection.

Consider the motion in vertically upward direction.

$$\text{Applying, } v = u + at$$

$$\Rightarrow 0 = u \sin \theta - gt$$

$$\Rightarrow \boxed{t = \frac{u \sin \theta}{g}}$$

### **Time of Flight:**

It is the total time taken by the projectile during motion.

Since the time of ascent is equal to the time of descent so that total time taken

$$T = 2t$$

$$\Rightarrow \boxed{T = \frac{2u \sin \theta}{g}}$$

### **Horizontal Range:**

It is the distance travelled by the projectile in horizontal direction.

$$R = (u \cos \theta)T$$

$$\Rightarrow R = (u \cos \theta) \left( \frac{2u \sin \theta}{g} \right)$$

$$\Rightarrow R = \frac{u^2 2 \sin \theta \cdot \cos \theta}{g}$$

$$\Rightarrow \boxed{R = \frac{u^2 \sin 2\theta}{g}}$$

\*

The range will be maximum if,

$$\sin 2\theta = 1$$

$$\Rightarrow 2\theta = 90^\circ$$

$$\Rightarrow \theta = 45^\circ$$

So, maximum horizontal Range,  $R_{\max} = \frac{u^2}{g}$

**Q. Find the angel of projection for which the horizontal range is equal to the maximum height.**

**A:**  $R = H$

$$\Rightarrow \frac{u^2 \sin 2\theta}{g} = \frac{u^2 \sin^2 \theta}{2g}$$

$$\Rightarrow 2 \sin \theta \cdot \cos \theta = \frac{\sin^2 \theta}{2}$$

$$\Rightarrow 2 \cos \theta = \frac{\sin \theta}{2}$$

$$\Rightarrow 4 \cos \theta = \sin \theta$$

$$\Rightarrow 4 = \frac{\sin \theta}{\cos \theta}$$

$$\Rightarrow 4 = \tan \theta$$

$$\Rightarrow \theta = \tan^{-1}(4) \quad \text{or} \quad \cot^{-1}(1/4).$$

**Q. For what angle the horizontal range should be maximum?**

A 
$$R = \frac{u^2 \sin 2\theta}{g}$$

$$\text{If } \sin 2\theta = 1 \Rightarrow 2\theta = 90 \Rightarrow \theta = 45^\circ$$

### Angular Displacement ( $\theta$ ):

When a particle moves in a circular path. The angular displacement is the angle subtended by the radius vector at the centre. Here  $\theta$  is the angular displacement.

$$\text{Dimension} = [ M^0 L^0 T^0 ]$$

$\Rightarrow$  When a body completes a circular path, its angular displacement is  $2\pi$

### Angular velocity ( $\vec{\omega}$ ):

It is the rate of change of angular displacement of the body.

$$\vec{\omega} = \frac{\vec{\theta}}{t}$$

Unit: radian / sec

$$\text{Dimension: } [ M^0 L^0 T^{-1} ]$$

$$\Rightarrow \text{Average angular velocity} = \frac{\text{Change in angular displacement}}{\text{Change in time}}$$

$$\vec{\omega}_{av} = \frac{\vec{\theta}_2 - \vec{\theta}_1}{t_2 - t_1}$$

⇒ Instantaneous angular velocity

$$\vec{\omega} = \frac{d\vec{\theta}}{dt}$$

⇒ If  $V$  is the linear velocity

$$\vec{v} = \frac{d\vec{s}}{dt} = \frac{d}{dt}(r\theta) = r \frac{d\theta}{dt}$$

⇒  $V = r\omega$

⇒ If a body completes a circular path in a time period  $T$ , the angular velocity.

$$\omega = \frac{2\pi}{T}$$

⇒ If  $\eta$  or  $f$  is the frequency of revolution,

$$f = \frac{1}{T}$$

$$\text{So, } \omega = \frac{2\pi}{T} = 2\pi f$$

### Angular Acceleration ( $\alpha$ ):

It is defined as the rate of change of angular velocity,  $\alpha = \frac{\omega}{t}$

Unit : radian /sec<sup>2</sup>

Dimension : [ M<sup>0</sup> L<sup>0</sup> T<sup>-2</sup> ]

$$\vec{\alpha}_{\text{Avg}} = \frac{\text{change in angular velocity}}{\text{change in time}} = \frac{\vec{\omega}_2 - \vec{\omega}_1}{t_2 - t_1}$$

⇒ Instantaneous angular acceleration

$$\vec{\alpha} = \frac{d\vec{\omega}}{dt}$$

⇒ If 'a' is the linear acceleration

$$a = \frac{dv}{dt} = \frac{d}{dt}(r\omega) = r \frac{d\omega}{dt} = r\alpha$$

Q. Find the angular velocity of the second hand of a watch.

A 
$$\omega = \frac{2\pi}{T} = \frac{2\pi}{60} = \frac{\pi}{30} \text{ rad / sec.}$$

\* For minute hand 
$$\omega = \frac{2\pi}{60 \times 60} = \frac{\pi}{1800} \text{ rad / sec.}$$

\* For hour hand 
$$\omega = \frac{2\pi}{12 \times 3600} = \frac{\pi}{21600} \text{ rad / sec.}$$

Q. The length of the second hand of a clock is 5cm find its linear velocity

A.  $r = 5\text{cm}$

Angular velocity of second hand

$$\omega = \frac{2\pi}{60} = \frac{\pi}{30} \text{ rad / sec.}$$

$$v = r\omega$$

$$\Rightarrow v = 5 \times \frac{\pi}{30} = \frac{\pi}{6} = \frac{3.14}{6} \text{ cm / sec} = 0.52 \text{ cm / sec.}$$



**UNIT - 4**  
**WORK AND FRICTION**

**WORK**

- Work is said to be done when the force acting on a body and the body displaces through certain displacement and force has a component along the displacement.

- $W = \vec{F} \cdot \vec{S} = FS \cos \theta$

Case I

(If  $\theta = 0^\circ$ ,  $\cos \theta = 1 \Rightarrow W = FS$  (Positive work))

i.e The work done is positive if the force and displacement are in same direction.

Case II

(If  $\theta = 180^\circ$ ,  $\cos \theta = -1 \Rightarrow W = -FS$  (Negative work))

i.e the work done is negative if the force and displacement are in opposite direction.

Case III

(If  $\theta = 90^\circ$ ,  $\cos \theta = 0 \Rightarrow W = 0$  (Zero work))

i.e No work is done when the force and displacement are perpendicular to each other .

- Dimensional formula of work = [  $M^1L^2T^{-2}$  ]
- SI unit of work Joule  
1 Joule = 1 N  $\times$  1m
- CGS unit of work erg  
1 erg = 1 dyne  $\times$  1 cm
- 1 Joule =  $10^7$  erg

**Friction :**

- When a body moves over a rough surface the force which opposes the motion of the body is called force of friction .
- The force of friction is always opposite to the direction of motion .
- It acts parallel to the surface .
- The force of friction depends upon
  - 1) Nature of two surfaces in contact.
  - 2) The normal reaction with which the body and the surface being pressed together .

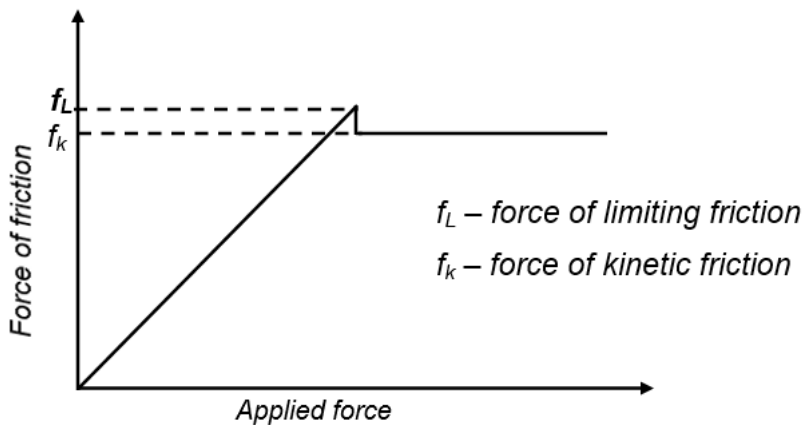
**Static friction :**

The force of friction between the body and the surface so long as there is no relative motion is called static friction .

**Limiting friction:**

The maximum value of the static friction is known as limiting friction.

**Dynamic friction:**

The force of friction between the body and the surface so long as there is a relative motion between them is called dynamic friction .

### **Laws of limiting friction:**

1. The force of friction depends upon the nature of two surfaces and it is opposite to direction of motion of the body.
2. The force of friction acts parallel to the surface .
3. The force of friction directly proportional to normal reaction .  

$$\text{i.e } F \propto R \Rightarrow F = \mu R \quad (\mu \text{ is the coefficient of friction})$$
4. The force of limiting friction is independent of the area of contact till the normal reaction remains constant

### **Coefficient of friction:**

The coefficient of friction between two surfaces is defined as the ratio between the force of friction and the normal reaction .

$$F = \mu R$$

$$\Rightarrow \mu = F / R$$

$\mu$  has no unit and dimension .

### **Methods of reducing frictional force :**

1. By rubbing and polishing the surfaces .
2. By using the lubricants.
3. By decreasing the area of contact between the body and surface .
4. By streamlining .

## UNIT-5 Gravitation

### Newton's law of Gravitation:

The gravitational force of attraction between two bodies is directly proportional to the product of their masses and inversely proportional to the square of the distance between them.

Consider two bodies of masses  $M_1$  and  $M_2$  separated by a distance  $r$ .

$$F \propto M_1 M_2$$

$$F \propto 1/r^2$$

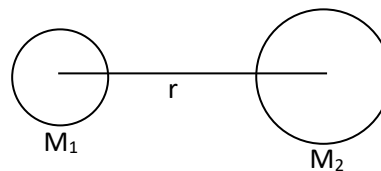

Combining these two equations

$$\Rightarrow F = G \frac{M_1 M_2}{r^2}$$

Where  $G$  is known as universal gravitational constant.

$$G = \frac{Fr^2}{M_1 M_2}$$

If  $M_1 = M_2 = 1$  unit,  $r = 1$  unit.

then,  $G = F$

so, the gravitational constant is defined as the gravitational force of attraction between two bodies each of mass 1 unit separated by a distance of 1 unit.

- The value of  $G$  is same everywhere in the universe.

$$G = 6.67 \times 10^{-11} \text{ Nm}^2 / \text{Kg}^2 \quad (\text{in M.K.S system})$$

$$G = 6.67 \times 10^{-8} \text{ dyne cm}^2 / \text{g}^2 \quad (\text{in C.G.S. system})$$

- Dimension :  $[ M^{-1}L^3T^{-2} ]$

### Relation between g and G :

The force with which a body is attracted towards the center of earth is called gravity.

Consider a body of mass 'm' placed on the surface of earth

The weight of the body = mg

The force of attraction between the earth and the body

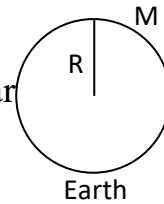

$$F = G \frac{Mm}{R^2}$$

Where,  $M \rightarrow$  Mass of earth

$R \rightarrow$  Radius of earth

So,  $mg = G \frac{Mm}{R^2}$

$$\Rightarrow g = G \frac{M}{R^2} \quad (\text{This is the relation between } g \text{ and } G)$$

- The value of 'g' on the surface of earth.  
 $g = 9.8 \text{ m/sec}^2 = 980 \text{ cm / sec}^2 = 32 \text{ ft / sec}^2$
- The value of 'g' is independent of the mass of the body.
- It depends upon mass and the radius of the planet
- Since the value of g is different for different places, the weight of a body is different at different places.

### Difference between Mass and Weight :

<b>Mass</b>	<b>Weight</b>
<ul style="list-style-type: none"> <li>• The mass of a body is the amount of substance contained in the body.</li> </ul>	<ul style="list-style-type: none"> <li>• The weight of a body is the force with which the body is attracted towards the center of earth</li> </ul>

<ul style="list-style-type: none"> <li>• Mass of body is same at all points.</li> </ul>	<ul style="list-style-type: none"> <li>• Weight of a body is different at different places due to variation of g.</li> </ul>
<ul style="list-style-type: none"> <li>• Mass is a fundamental quantity.</li> </ul>	<ul style="list-style-type: none"> <li>• Weight is a derived quantity.</li> </ul>
<ul style="list-style-type: none"> <li>• Mass is a scalar quantity.</li> </ul>	<ul style="list-style-type: none"> <li>• Weight is a vector quantity.</li> </ul>
<ul style="list-style-type: none"> <li>• Unit : Kilogram gram</li> </ul>	<ul style="list-style-type: none"> <li>• Unit : Newton , Kgf Dyne , gmf</li> </ul>

### Variation of g with Altitude / Height:

The acceleration due to gravity at any point on the surface of earth.

$$g = G \frac{M}{R^2} \quad - (1)$$

where,  $M$  = Mass of earth.

$R$  = Radius of earth.

The acceleration due to gravity at a height 'h' from the surface of earth

$$g^1 = G \frac{M}{(R+h)^2} \quad - (2)$$

$$\Rightarrow \frac{g^1}{g} = 1 - \frac{2h}{R}$$

$$\Rightarrow g^1 = g \left( 1 - \frac{2h}{R} \right)$$

$$\text{Or } g^1 = g - \frac{2gh}{R}$$

$$\Rightarrow g - g^1 \propto h$$

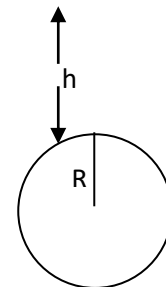

i.e with increase in height from the surfaces of earth the acceleration due to gravity decreases.

- Loss in weight of a body.

$$mg - mg^1 = \frac{2mgh}{R}$$

**Variation of g with Depth :**

The acceleration due to gravity at any point on the surface of earth.

$$g = G \frac{M}{R^2}$$

Where,  $M \rightarrow$  mass of earth,  $R \rightarrow$  Radius of earth

At a depth 'd' from the surface of earth

$$g^1 = g (1-d/R)$$

$$\Rightarrow g^1 = g - \frac{gd}{R}$$

$$\Rightarrow g - g^1 = \frac{gd}{R}$$

$$\Rightarrow (g - g^1) \propto d$$

With the increase in depth from the surface of earth the acceleration due to gravity decreases.

At the centre of earth.

$$d = R$$

$$\text{So, } g = g (1 - R/R)$$

$$\Rightarrow g (1-1) = 0$$

$$\Rightarrow g_{\text{centre}} = 0$$

i.e The acceleration due to gravity at the centre of earth is zero. So the weight of a body at the centre of earth is zero.

**Q. The mass of moon is  $\frac{1}{80}$  times and its radius is  $\frac{1}{4}$  that of earth.**

**Find the acceleration due to gravity on the surface of moon.**

**If a body weights 50 kg on the earth . What will be its weight on the surface of**

**moon.**

$$\text{A: i) } M_m = \frac{1}{80} M, \quad R_m = \frac{1}{4} R$$

$$\text{On earth, } g = G \frac{M}{R^2}$$

$$\text{On moon, } g_m = G \frac{M_m}{R_m^2}$$

$$\text{Dividing, } \frac{g_m}{g} = \frac{M_m}{M} \times \frac{R^2}{R_m^2}$$

$$\Rightarrow \frac{g_m}{g} = \frac{1}{80} \times (4)^2 = \frac{16}{80} = \frac{1}{5}$$

$$\Rightarrow g_m = \frac{g}{5} = \frac{9.8}{5} = 1.96 \text{ m/s}^2$$

$$\text{ii) } \frac{\text{wt. of a body on moon}}{\text{wt. of the body on earth}} = \frac{g_m}{g} = \frac{1}{5}$$

$$\Rightarrow \text{wt. of the body on moon} = \frac{1}{5} \times \text{wt. of the body on earth.}$$

$$\frac{1}{5} \times 50 = 10 \text{ kgf}$$

**Q. A body weights 36 kg wt on the surface of earth. How much will it weight on the surface of a planet. Whose mass is  $\frac{1}{9}$  and radius  $\frac{1}{2}$  that of earth.**

$$\text{A: } M_p = \frac{M_e}{9}, \quad R_p = \frac{R_e}{2}$$

$$\frac{g_p}{g_e} = \frac{M_p}{M_e} \times \left( \frac{R_e}{R_p} \right)^2 = \frac{1}{9} \times (2)^2 = \frac{4}{9}$$

$$\Rightarrow \frac{w_p}{w_e} = \frac{mg_p}{mg_e} = \frac{g_p}{g_e} = \frac{4}{9}$$

$$\Rightarrow w_p = \frac{4}{9} \times w_e = \frac{4}{9} \times 36 = 16 \text{ kgwt}$$



Q. Find the acceleration due to gravity at a depth equals to half of the radius of earth.

A:  $d = R/2$

$$\text{At a depth, } g^1 = g \left( 1 - \frac{d}{R} \right)$$

$$\Rightarrow g^1 = g \left( 1 - \frac{R/2}{R} \right) = g \left( 1 - \frac{1}{2} \right)$$

$$\Rightarrow g^1 = \frac{g}{2} = \frac{9.8}{2} = 4.9 \text{ m/sec}^2$$

### Kepler's laws of planetary motion:

#### 1<sup>st</sup> law (law of orbit)

All the planets revolve around the sun in elliptical orbits and the sun is situated at one of its foci.

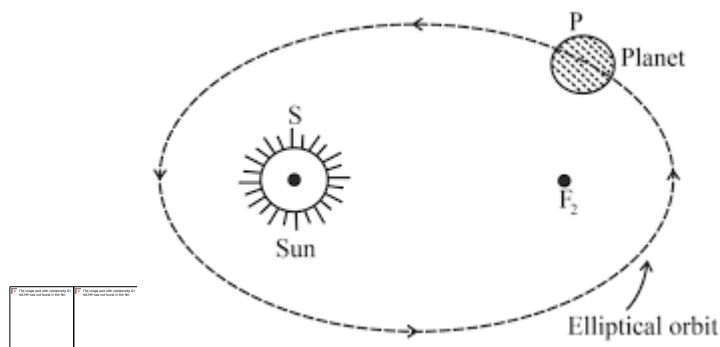

#### 2<sup>nd</sup> law (law of area) :

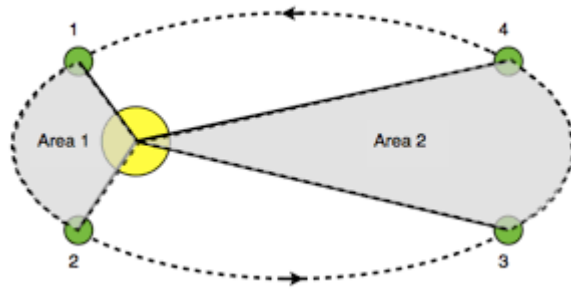

When a planet revolves around the sun it sweeps out equal area in equal interval of time

i.e. during planetary motion the areal velocity remains constant.

$$\frac{dA}{dt} = \text{Constant.}$$

**3<sup>rd</sup> law (Law of time period or Harmonic law) :**

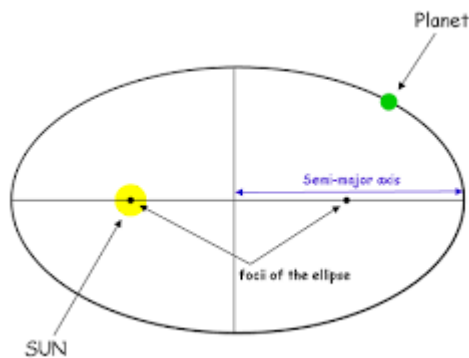

When a planet revolves around the sun the square of the time period is proportional to the cube of the semi major axis.

$$T^2 \propto R^3$$

$$\Rightarrow \frac{T^2}{R^3} = \text{constant.}$$

For two planets,  $\frac{T_1^2}{T_2^2} = \frac{R_1^3}{R_2^3}$

## UNIT-6 Oscillations and Waves

### Simple Harmonic Motion (SHM):

The motion of a particle is said to be simple harmonic if

- i) Its acceleration is directly proportional to displacement .
- ii) The acceleration is directed towards the mean position.  
i.e Acceleration and displacement are in opposite direction.

$$a \propto y$$

$a = -\omega^2 y$ , -ve sign is due to the acceleration and the displacement are opposite to each other.

### Displacement:

The displacement of a particle executing SHM at any time is the distance from the mean position.

In  $\Delta OMP$

$$\sin \omega t = \frac{OM}{OP} = \frac{y}{r}$$

$$y = r \sin \omega t$$

At mean position,  $y = 0$

At extreme position,  $y = r$  (Maximum)

**The maximum displacement of a particle executing SHM is known as the amplitude.**

### **Velocity:**

The rate of change of displacement of the particle is called velocity.

$$V = \frac{dy}{dt}$$

$$V = \frac{d}{dt} (r \sin \omega t)$$

$V = r\omega \cos \omega t$
-----------------------------

$$\cos \omega t = \frac{PM}{OP} = \frac{\sqrt{r^2 - y^2}}{r}$$

$$\text{So, } V = \omega \sqrt{r^2 - y^2}$$

At mean position,  $y = 0$ ,  $V = r\omega$  (Maximum) ,

At extreme position,  $y = r$ ,  $V = 0$  (Minimum)

### **Acceleration:**

It is the rate of change of velocity of the particle.

$$a = \frac{dv}{dt} \Rightarrow a = \frac{d}{dt} (r\omega \cos \omega t)$$

$$a = -\omega^2 y$$

At mean position,  $a=0$  (minimum)

At extreme position,  $y=r$ ,  $a= \omega^2 r$  (Maximum)

Q. A particle executing S.H.M has maximum velocity of  $1.00 \text{ ms}^{-1}$  and a maximum acceleration of  $1.57 \text{ ms}^{-2}$  calculate its time period.

A. Dividing  $\frac{\omega^2 r}{\omega r} = \frac{1.57}{1.00}$

$$\omega = 1.57 \text{ rad s}^{-1}$$

$$\therefore \text{Time period } T = \frac{2\pi}{\omega} = \frac{2\pi}{1.57} = 4 \text{ sec}$$

Q. A particle vibrating S.H.M along the line of length 20 cm. If its period is 3.14 sec. Find its velocity at mean position.

A Here,  $2r = 20$

$$\Rightarrow r = 10 \text{ cm}$$

Since, Velocity at mean position  $V = \omega r$

$$= \frac{2\pi}{T} \times 10 = \frac{2 \times 3.14}{3.14} \times 10 = 20 \text{ cms}^{-1}$$

<b>Transverse Wave</b>	<b>Longitudinal Wave</b>
<ul style="list-style-type: none"> <li>It is that type of wave motion in which the particles of the</li> </ul>	<ul style="list-style-type: none"> <li>It is that type of wave motion in which the particles of the</li> </ul>

medium vibrate in a direction perpendicular to the direction of motion of the wave.	medium vibrate in a direction same as the direction of motion of the wave.
<ul style="list-style-type: none"> <li>• It forms crests and troughs.</li> </ul>	<ul style="list-style-type: none"> <li>• It forms compression and rarefaction.</li> </ul>
<ul style="list-style-type: none"> <li>• <b>Ex</b> - Light wave Electromagnetic wave, Vibration in a stretched string.</li> </ul>	<ul style="list-style-type: none"> <li>• <b>Ex</b>- Sound wave Vibration in air column (organ pipe)</li> </ul>

### Stationary Wave (Standing Wave) :

A stationary wave is formed due to superposition of two waves of same amplitude, same wavelength and same frequency, travel in a medium in opposite direction.

- ✓ The points in the stationary wave at which the amplitude becomes zero are called **Nodes** and the points at which the amplitude becomes maximum are called **antinodes**.

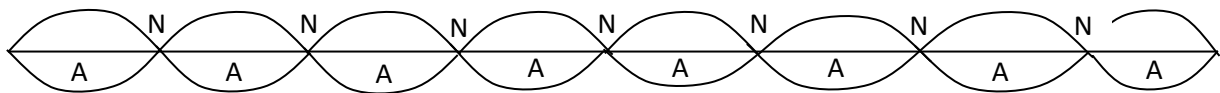

- The distance between two consecutive Nodes is  $\lambda/2$ .
  - The distance between two consecutive anti nodes is  $\lambda/2$ .
  - The distance between a node and next anti nodes is  $\lambda/4$ .
- ✓ Since, the position of the nodes and the anti nodes do not change with time. These waves are called stationary waves

<b>Progressive wave</b>	<b>Stationary wave</b>
-------------------------	------------------------

i) Disturbance is communicated from one particle to the next particle	i) Disturbance is not communicated from one particle to the next particle.
ii) Amplitude of earth particle is same.	ii) Amplitude of different particles is different. It is zero at nodes and maximum at anti nodes.
iii) There is a gradual change of phase from one particle to another.	iii) Phase of all particles are same.
iv) No particle is permanently at rest.	iv) The particles at nodes are at rest.
v) There is a flow of energy from one particle to the next particle.	v) There is no flow of energy from one particle to other.

### Wave Length ( $\lambda$ ):

It is the distance covered by the wave in a complete time period.

**Or**

It is the distance between two consecutive crests or between two consecutive troughs.

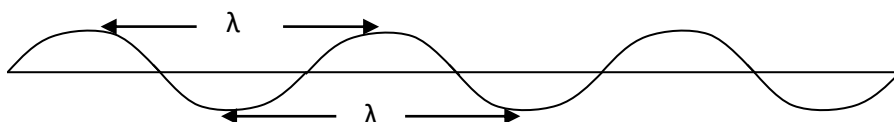

### Relation Between Velocity, Wavelength & Frequency of a wave :

$$\text{Velocity} = \frac{\text{Distance}}{\text{Time}}$$

Since,  $\lambda$  is the distance covered by the wave in a time period  $T$ ,

$$v = \frac{\lambda}{T}$$

$$\Rightarrow v = \lambda f,$$

Where  $f = \frac{1}{T}$ , is the frequency

$$\text{velocity} = \text{wavelength} \times \text{frequency}$$

### **Ultrasonic**

Sound of frequency greater than the upper limit of audible range ( 20 Hz to 20 KHz ) is known as ultrasonic .

Properties:

- Ultrasonic waves are longitudinal in nature.
- Ultrasonic waves are of high frequency Range of (  $2 \times 10^4$  to  $10^9$  Hz)
- They travel with the speed of sound.
- They constitute narrow beams.

### **Applications:**

- Echo sounding,
- Thickness gauging
- Drilling holes.
- Ultrasonic welding



## UNIT -7

### Heat and Thermodynamics

#### Heat :

It is a form of energy which is transferred one body to another when there is a temperature difference between them.

Unit : calorie ( in C.G.S )

1 calorie is the amount of heat required to raise the temperature of 1 gram of water through  $1^{\circ}\text{C}$ .

$$1 \text{ calories} = 4.2 \text{ joule.}$$

KCal ( in S.I. )

1 Kcal. is amount of heat required to raise the temperature of 1 Kg.of water through  $1^{\circ}\text{C}$ .

$$1 \text{ Kcal} = 10^3 \text{ cal} = 4200 \text{ joule.}$$

#### Temperature :

Temperature is the measure of degree of hotness and coldness of a body .

Unit ; kelvin ,Celsius

#### Specific Heat :

The specific heat of a body is defined as the amount of heat required to raise the temperature of unit mass of the body through  $1^{\circ}\text{C}$ .

The amount of heat required.

$$Q = mS \Delta\theta$$

$$S = \frac{Q}{m\Delta\theta}$$

If  $m = 1$  unit,  $\Delta\theta = 1^{\circ}\text{C}$ .

Then  $S = Q$

- **Unit** : cal / gm<sup>0</sup>C (in CGS)

K cal/ kg <sup>0</sup>C ( in S.I.)

- **Dimensions** :  $S = \frac{Q}{m\Delta\theta} = \frac{M^1L^2T^{-2}}{MK} = [M^0L^2T^{-2}K^{-1}]$

→ **For water**,  $S = 1 \text{ cal / gm}^{\circ}\text{C} = 1 \text{ K cal / Kg}^{\circ}\text{C}$ .

→ **For ice**  $S = 0.5 \text{ cal / gm}^{\circ}\text{C} = 0.5 \text{ Kcal / kg}^{\circ}\text{C}$ .

### Latent Heat :

It is defined as the amount of heat required to convert the unit mass of a substance from one state to another without change in its temperature.

$$Q = mL \Rightarrow L = \frac{Q}{m}$$

- **Unit** : cal/ gm, K cal/ kg

- **Dimension** :  $\frac{M^1L^2T^{-2}}{M} = [M^0L^2T^{-2}]$

**For ice**  $Q = m L_f$

( From ice 0<sup>0</sup>C to water at 0<sup>0</sup>C )  $L_f = 80 \text{ cal/ gm} = 80 \text{ K cal/ kg}$

**For water**  $Q = m L_v$ .

( from water at 100<sup>0</sup>C to steam at 100<sup>0</sup>C ) ,  $L_v = 540 \text{ cal/ gm} = 540\text{Kcal/Kg}$ .

Q. What is the amount of heat required to melt 5 gm of ice at  $0^{\circ}\text{C}$  to water at  $0^{\circ}\text{C}$

A :  $5 \times 80 = 400 \text{ cal}$

Q Calculate the amount of heat required to raise the temp. of 50 gm of water from  $10^{\circ}\text{C}$  to  $25^{\circ}\text{C}$ .

A  $Q = ms\Delta\theta$

Here  $m = 50\text{gm}$ .  $S=1$ ,  $\Delta\theta = 25 - 10 = 15$

$Q = 50 \times 1 \times 15 = 750 \text{ cal}$ .

Q. What is the amount of heat required to convert 10 gm of ice at  $-5^{\circ}\text{C}$  to water at  $20^{\circ}\text{C}$ .

A From ice at  $-5^{\circ}\text{C}$  to ice at  $0^{\circ}\text{C}$

$$\begin{aligned} Q_1 &= ms\Delta\theta \\ &= 10 \times 0.5 \times 5 = 25 \text{ cal.} \end{aligned}$$

From , ice at  $0^{\circ}\text{C}$  to water at  $0^{\circ}\text{C}$ .

$$\begin{aligned} Q_2 &= mL \\ &= 10 \times 80 = 800 \text{ cal.} \end{aligned}$$

From , water at  $0^{\circ}\text{C}$  to water at  $20^{\circ}\text{C}$ .

$$\begin{aligned} Q_3 &= ms\Delta\theta \\ &= 10 \times 1 \times 20 = 200 \text{ cal.} \end{aligned}$$

So, total heat required

$$\begin{aligned} Q &= Q_1 + Q_2 + Q_3 \\ &= 25 + 800 + 200 \\ &= 1025 \text{ cal.} \end{aligned}$$

### Coefficient of thermal expansion of solids :

- **Coefficient of linear expansion ( $\alpha$ )**

It is defined as the change in length per original length per degree rise in temperature.

$$\alpha = \frac{L_t - L_0}{L_0 t}$$

Unit -  $^{\circ}\text{C}^{-1}$

- **Coefficient of superficial /Areal expansion ( $\beta$ )**

It is defined as the change in area per original area per degree rise in temperature.

$$\beta = \frac{A_t - A_0}{A_0 t}$$

Unit -  $^{\circ}\text{C}^{-1}$

- **Coefficient of cubical /volume expansion ( $\gamma$ )**

It is defined as the change in volume per original volume per degree rise in temperature.

$$\gamma = \frac{V_t - V_0}{V_0 t}$$

Unit -  $^{\circ}\text{C}^{-1}$

### Relation between $\alpha$ and $\beta$ :

Consider a square sheet having each side of length  $L_0$  at  $0^{\circ}\text{C}$  and  $L_t$  at  $t^{\circ}\text{C}$ .

So, it, area at  $0^{\circ}\text{C}$ ,  $A_0 = L_0^2$ .

area at  $t^{\circ}\text{C}$ ,  $A_t = L_t^2$

We have ,  $\alpha = \frac{L_t - L_0}{L_0 t}$

$$\Rightarrow L_t - L_0 = \alpha L_0 t$$

$$\Rightarrow L_t = L_0 + \alpha L_0 t$$

$$\Rightarrow L_t = L_0(1 + \alpha t)$$

Again, 
$$\beta = \frac{A_t - A_0}{A_0 t}$$

$$\Rightarrow \beta = \frac{L_t^2 - L_0^2}{L_0^2 t}$$

$$\Rightarrow \beta = \frac{L_0^2(1 + \alpha t)^2 - L_0^2}{L_0^2 t}$$

$$\Rightarrow \beta = \frac{1 + 2\alpha t + \alpha^2 t^2 - 1}{t}$$

$$\Rightarrow \beta = \frac{2\alpha t + \alpha^2 t^2}{t}$$

$$\Rightarrow \beta = \frac{(2\alpha + \alpha^2 t)t}{t}$$

$$\Rightarrow \beta = 2\alpha + \alpha^2 t$$

Since,  $\alpha$  is very small the higher powers of  $\alpha$  can be neglected.

So,  $\boxed{\beta = 2\alpha}$

### Relation Between $\alpha$ and $\gamma$

Consider a cubical body having each side of length  $L_0$  at  $0^\circ\text{C}$  and  $L_t$  at  $t^\circ\text{C}$

So, its volume at  $0^\circ\text{C}$ ,  $V_0 = L_0^3$

at  $t^\circ\text{C}$ ,  $V_t = L_t^3$

we have,

$$\alpha = \frac{L_t - L_0}{L_0 t}$$

$$\Rightarrow L_t - L_0 = \alpha L_0 t$$

$$\Rightarrow L_t = L_0(1 + \alpha t)$$

$$\begin{aligned}
\text{Now } \gamma &= \frac{V_t - V_0}{V_0 t} \\
\Rightarrow \gamma &= \frac{L_t^3 - L_0^3}{L_0^3 t} \\
\Rightarrow \gamma &= \frac{L_t^3 (1 + \alpha t)^3 - L_0^3}{L_0^3 t} \\
\Rightarrow \gamma &= \frac{L_t^3 (1 + \alpha t)^3 - L_0^3}{L_0^3 t} \\
\Rightarrow \gamma &= \frac{(1 + \alpha t)^3 - 1}{t} \\
\Rightarrow \gamma &= \frac{1 + 3\alpha t + 3\alpha^2 t^2 + \alpha^3 t^3 - 1}{t} \\
\Rightarrow \gamma &= \frac{3\alpha t + 3\alpha^2 t^2 + \alpha^3 t^3}{t} \\
\Rightarrow \gamma &= \frac{t(3\alpha + 3\alpha^2 t + \alpha^3 t^2)}{t} \\
\Rightarrow \gamma &= 3\alpha + 3\alpha^2 t + \alpha^3 t^2
\end{aligned}$$

Since  $\alpha$  is very small the higher powers of  $\alpha$  can be neglected.

So  $\gamma = 3\alpha$

- Since ,  $\beta = 2\alpha$

$$\Rightarrow \alpha : \beta : \gamma = 1 : 2 : 3$$

Q The length of a rod at  $0^\circ\text{C}$  is 50cm and 52cm at  $100^\circ\text{C}$ . Find the co-efficient of linear expansion.

$$A \quad \alpha = \frac{L_t - L_0}{L_0 t}$$

Here,  $L_0 = 50\text{cm}$ ,  $L_t = 52\text{ cm}$ ,  $t = 100^\circ\text{C}$

$$\alpha = \frac{52 - 50}{50 \times 100} = \frac{2}{5 \times 10^3} = 0.4 \times 10^{-3}$$

$$\Rightarrow \quad \alpha = 4 \times 10^{-4} \text{ } ^\circ\text{C}^{-1}$$

$$\text{So } \alpha = 0.0004 \text{ } ^\circ\text{C}^{-1}$$

### First law of Thermodynamics :

**Statement :** If some amount of heat given to a system is capable of doing some work, then amount of heat is equal to the sum of the change in internal energy and the amount of work done.

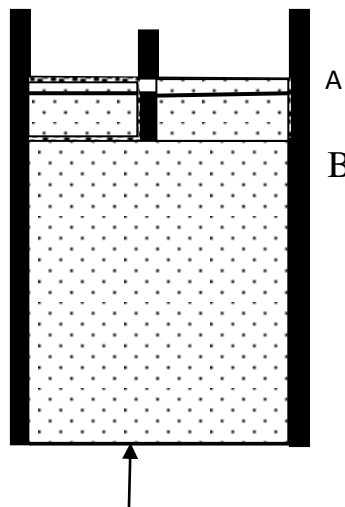

Consider some gas is taken in a barrel having insulating walls and conducting bottom. It is also provided with an insulating piston.

Let  $Q$  amount of heat given to the system.  $U_1$  is the initial internal energy.

Now the total energy in the beginning =  $U_1 + Q$

When heat is given to the system , the internal energy changes and the gas is expanded (i.e some work is done .)

If  $U_2$  is the final internal energy ,  $W$  is the work done

Then the total energy at the end =  $U_2 + W$

According to conservation of energy ,  $U_1 + Q = U_2 + W$  ,      So,  $Q = (U_2 - U_1) + W$

Amount of heat = (change in internal energy ) +( work done )

### Thermal conductivity :

The amount of heat flows from one face to another of a body.

$Q \propto A$ ,       $A \rightarrow$  Area of each face.

$Q \propto (\theta_1 - \theta_2)$ ,      temp. difference between two face

$\propto t$  ,      time of flow of heat

$\propto 1/d$  ,      d-Distance between two faces.

Combining,  $Q \propto \frac{A(\theta_1 - \theta_2)t}{d}$

$$Q = K \frac{A(\theta_1 - \theta_2)t}{d}$$

$$\Rightarrow K = \frac{Qd}{A(\theta_1 - \theta_2)t}$$

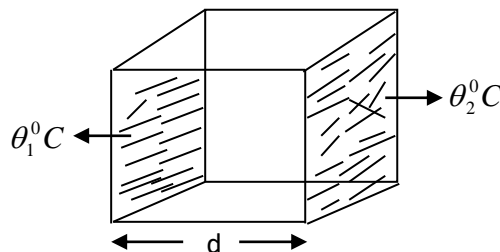

$K$  is known as coefficient of thermal conductivity.

$\rightarrow$  If  $A = 1$  unit,  $d = 1$  unit,  $t = 1$  sec,  $(\theta_1 - \theta_2) = 1^0 C$

Then,  $K = Q$

i.e the coefficient of thermal conductivity of the material of a body is defined as the amount of heat flows per sec. between the two faces of a body having each face of area 1 unit when the temperature different between them is  $1^0 C$ .



\* Unit of K

$$K = \frac{Qd}{A(\theta_1 - \theta_2)t}$$

- Cgs unit :  $\frac{\text{cal}}{\text{cm}^2 \text{C} \cdot \text{sec}}$  (in CGS)
- SI unit :  $\frac{\text{Watt}}{\text{m}^2 \text{C}}$  (in SI)
- Dimensions of K :  $[ M^1 L^1 T^{-3} K^{-1} ]$

**Mechanical Equivalent of Heat (J) :**

$$W \propto H$$

$$\Rightarrow W = JH$$

$$\Rightarrow J = \frac{W}{H}$$

If H = 1 unit, then J = W

i.e Mechanical equivalent of heat is defined as the amount of work done to produce unit amount of heat.

- $J = 4.2 \text{ joule / cal} = 4.2 \times 10^7 \text{ erg/ cal.}$

## UNIT-8 OPTICS

### Laws of reflection :

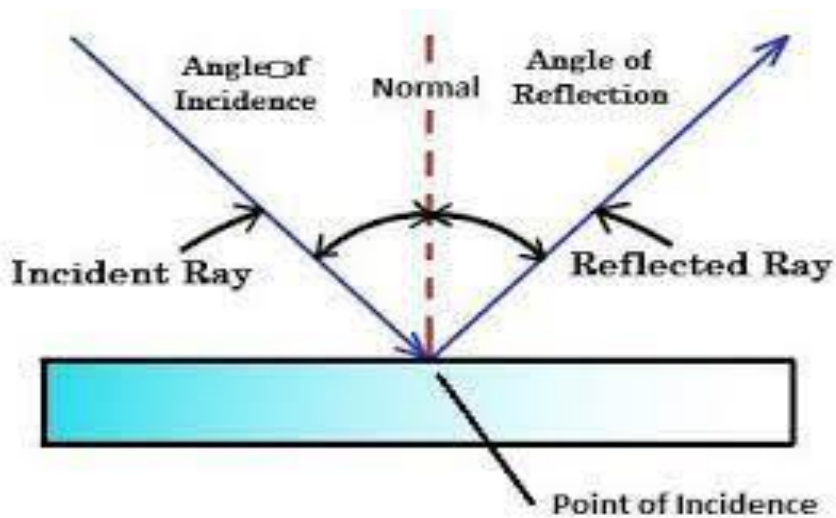

- i) The incident ray, the reflected ray and the normal at the point of incidence all lie in the same plane.
- ii) The angle of incidence and the angle of reflection are same.  
i.e  $\angle i = \angle r$

### Laws of Refraction :

- i) The incident ray, the refracted ray and the normal all lie in the same plane.
- ii) The ratio between the sin of angle of incidence and the sin of angle of refraction is always constant.

$$\frac{\sin i}{\sin r} = {}^1\mu_2 = \text{constant}$$

Which is known as Snell's law.

${}^1\mu_2 \rightarrow$  Refractive index of medium 2 w.r.t. medium 1

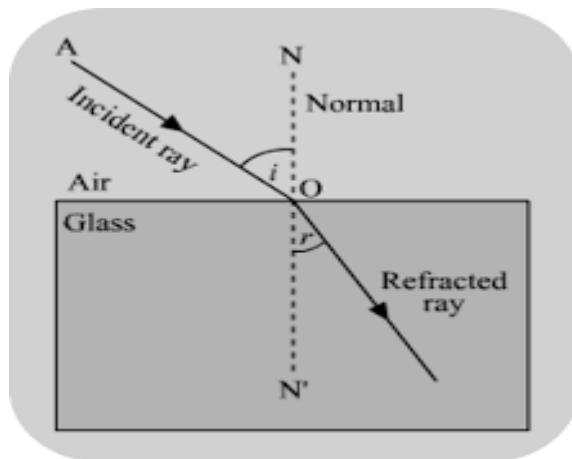

### Refractive Index :

Refractive index of a medium is defined as the ratio between the velocity of light in air medium and the velocity of light in that medium.

$$\mu = \frac{c}{v}$$

$\rightarrow$  It has no unit and dimension.

$\rightarrow$  For air medium .  $\mu = \frac{c}{c} = 1$

For any other medium  $C > V \Rightarrow \mu > 1$

$\rightarrow$  Refractive index of 2<sup>nd</sup> medium w.r.t 1<sup>st</sup> medium

### Total Internal Refraction and Critical Angle :

When a ray of light moves from dense medium to rarer medium the angle of incidence for which the angle of refraction is  $90^\circ$  is known as critical angle.

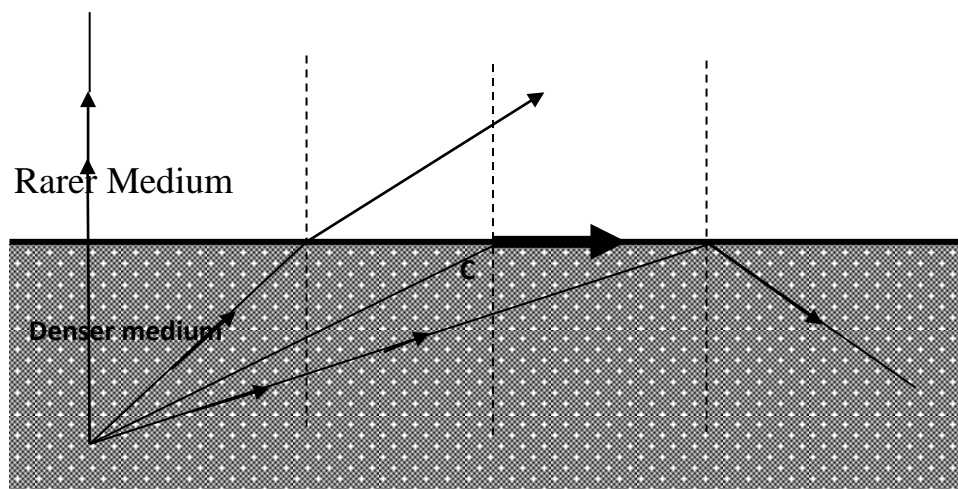

When the ray of light moves from denser to rarer medium, if the angle of incidence is greater than the critical angle, the ray reflected back to the same medium. This phenomenon is known as total internal reflection.

From Snell's law.

$$\frac{\sin i}{\sin r} = {}^1\mu_2 = \mu$$

If  $i=c$  then  $r=90^\circ$

$$\frac{\sin c}{\sin 90^\circ} = {}^D\mu_R$$

$$\sin C = {}^D\mu_R$$

$$\Rightarrow {}^R\mu_D = \frac{1}{\sin c}$$

If light moves from any denser medium to rarer medium, Refractive index of that dense medium

$$\mu = \frac{1}{\sin c}$$

→ In total internal reflection 100 % of the energy is reflected back to the same medium.

So the image formed due to total internal reflection is more brighter.

Eg. → Dazzling of Diamonds

→ Mirage formation

→ Optical fiber

### Refraction through a prism:

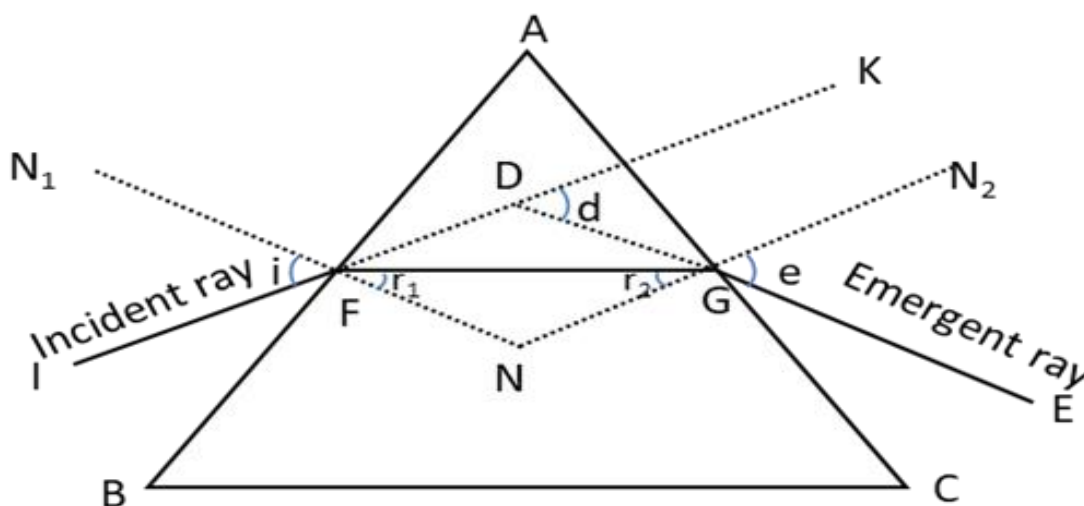

ABC is the prism

A- is the angle of prism

i- is the angle of incidence

r- is the angle of refraction

e- is the angle of emergence

D- is the angle of deviation

$d_m$  - is the angle of minimum deviation

AB and AC are two refracting faces of prism

Then refractive index of the material of prism is given by,

$$\mu = \frac{\sin\left(\frac{A + d_m}{2}\right)}{\sin\left(\frac{A}{2}\right)}$$

## UNIT-9 ELECTROSTATICS & MAGNETOSTATIC

### Coulomb's Law in Electrostatics :

The electrostatic force of attraction or repulsion between two point charges is directly proportional to the product of their magnitudes and inversely proportional to the square of the distance between them.

$$F \propto q_1 q_2$$

$$\propto 1/r^2$$

combining ,  $F \propto \frac{q_1 q_2}{r^2}$

$$\Rightarrow F = \beta \frac{q_1 q_2}{r^2}$$

- In C.G.S system ,  $\beta = 1$   
 $\Rightarrow F = \frac{q_1 q_2}{r^2}$
- In S. I. system ,  $\beta = 1/4\pi\epsilon_0$   
 $\Rightarrow F = \frac{1}{4\pi\epsilon_0} \frac{q_1 q_2}{r^2}$

Where  $\epsilon_0$  is called electric permittivity of free space.

$$\epsilon_0 = 8.85 \times 10^{-12} \text{ (coul)}^2 / \text{N.m}^2$$

$$\frac{1}{4\pi\epsilon_0} = 9 \times 10^9 \text{ Nm}^2 / \text{(coul)}^2$$

### Unit Charge :

If  $q_1 = q_2 = q$  (say),  $r = 1 \text{ m}$  and  $F = 9 \times 10^9 \text{ N}$

$$\text{So, } F = \frac{1}{4\pi \epsilon_0} \frac{q_1 q_2}{r^2}$$

$$9 \times 10^9 = 9 \times 10^9 \frac{q^2}{(1)^2}$$

$$\Rightarrow q^2 = 1$$

$$\Rightarrow q = 1 \text{ unit}$$

i.e. a unit charge is that which when placed near a similar charge at a distance of 1 m in air, repel by a force of  $9 \times 10^9$  N.

### **Relative permittivity:**

Permittivity is defined as the ability of a substance to store electrical energy in an electric field or the ability of a material to store electrical potential energy under the influence of an electric field.

The relative permittivity of a medium is defined as the ratio of the absolute permittivity of the medium and the permittivity of free space.

It has no unit and dimensional formula.

### **Electric Potential & Potential difference:**

The electric potential at any point is defined as the amount of work done in moving a unit +ve charge from infinity to that point.

The potential difference between two points is defined as the amount of work done in moving a unit +ve charge from one point to another.

$$V = \frac{W}{q_0}$$

\* Unit - Volt

### **Electric Field Intensity :**

The electric field intensity at any point is defined as the force per unit +ve charge placed at that point.

$$E = \frac{F}{q_0}$$



- **Unit :** N/ coulomb **or** Volt/m
- The electric field at any point due to a charge q.

$$F = \frac{1}{4\pi \epsilon_0} \frac{q}{r^2}$$

### **Capacity or Capacitance:**

The capacity of a conductor is the ability to store the charge.

It is defined as the ratio between the charge and the potential difference.

i.e  $C = \frac{Q}{V}$

or  $Q = CV$

- Unit : Farad

$$1 \text{ Farad} = \frac{1 \text{ coul}}{1 \text{ volt}}$$

- i. e the capacity is said to be 1 Farad if 1 coulomb charge is required to raise a potential of 1 volt.

### **Grouping of Capacitors :**

#### **(a) Capacitors in Series :**

The capacitors are said to be connected in series if the charge of each capacitor is same.

Consider a group of capacitors of capacitance  $C_1$  ,  $C_2$  ,  $C_3$  connected in series.

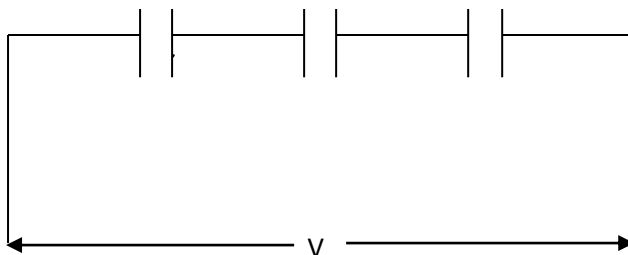

Let  $Q$  be the charge of each capacitor, If  $V_1, V_2, V_3$  are the potential difference across the capacitors respectively

$$V_1 = \frac{Q}{C_1}, V_2 = \frac{Q}{C_2}, V_3 = \frac{Q}{C_3}$$

If  $C_s$  is the equivalent or net capacitance of this series grouping.

The total potential difference

$$V = \frac{Q}{C_s}$$

Here,  $V = V_1 + V_2 + V_3$

$$\Rightarrow \frac{Q}{c_s} = \frac{Q}{c_1} + \frac{Q}{c_2} + \frac{Q}{c_3}$$

$$\Rightarrow \frac{Q}{c_s} = Q \left( \frac{1}{c_1} + \frac{1}{c_2} + \frac{1}{c_3} \right)$$

$$\Rightarrow \frac{1}{c_s} = \frac{1}{c_1} + \frac{1}{c_2} + \frac{1}{c_3}$$

i.e when the capacitors are connected in series the reciprocal of the net capacitance is equal to the sum of the reciprocals of their individual capacitance.

So, the net capacity decreases.

### (b) Capacitors in parallel:

The capacitors are said to be connected in parallel if the potential difference between the two plates of each capacitor is same.

Consider a group of capacitors of capacitance  $C_1, C_2, C_3$  connected in parallel.

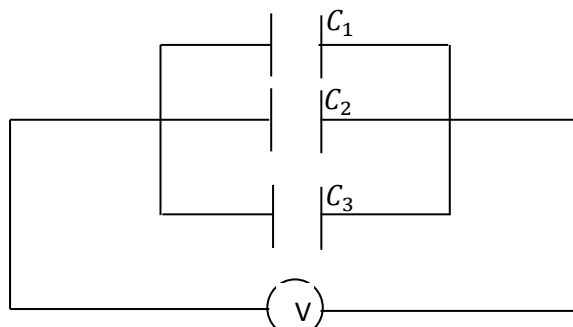

Let  $V$  be the potential difference between two plates of each capacitor.

If  $Q_1, Q_2, Q_3$  are their charges

Then,  $Q_1 = C_1V, Q_2 = C_2V, Q_3 = C_3V$

If  $C_p$  is the equivalent capacitance of this parallel grouping

The total charge,  $Q = Q_1 + Q_2 + Q_3$

$$C_p V = C_1 V + C_2 V + C_3 V$$

$$C_p V = (C_1 + C_2 + C_3) V$$

$$C_p = C_1 + C_2 + C_3$$

i.e when the capacitors are connected in parallel the net capacity is equals to the sum of their individual capacitance.

Thus the net capacitance increases.

**Q** Three capacitors of capacitance  $1 \mu\text{F}$ ,  $2 \mu\text{F}$  and  $3 \mu\text{F}$  are connected in series. Find the equivalent capacitance

**A**  $c_1 = 1 \mu\text{F}, c_2 = 2 \mu\text{F}, c_3 = 3 \mu\text{F}$

$$\frac{1}{c} = \frac{1}{c_1} + \frac{1}{c_2} + \frac{1}{c_3}$$

$$\Rightarrow \frac{1}{c} = \frac{1}{1} + \frac{1}{2} + \frac{1}{3}$$

$$\Rightarrow \frac{1}{c} = \frac{6+3+2}{6} = \frac{11}{6}$$

$$\Rightarrow c = \frac{6}{11} \mu\text{F}$$

**Q** When two capacitors are connected in parallel the net capacity is  $9 \mu\text{F}$  and when they are connected in series the net capacity is  $2 \mu\text{F}$ . Find their individual capacitance.

$$c_p = 9 \mu\text{F}$$

$$c_s = 2 \mu\text{F}$$

$$c_p = c_1 + c_2 = 9$$

$$\frac{1}{c_s} = \frac{1}{c_1} + \frac{1}{c_2}$$

$$\Rightarrow \frac{1}{2} = \frac{c_1 + c_2}{c_1 c_2} = \frac{9}{c_1 c_2}$$

$$\Rightarrow c_1 c_2 = 18.$$

Now

$$(c_1 - c_2)^2 = (c_1 + c_2)^2 - 4c_1 c_2$$

$$\Rightarrow (c_1 - c_2)^2 = (9)^2 - 4 \times 18$$

$$\Rightarrow (c_1 - c_2)^2 = 81 - 72$$

$$\Rightarrow (c_1 - c_2)^2 = 9$$

$$\Rightarrow (c_1 - c_2) = 3$$

Now, Solving we get

$$c_1 - c_2 = 3$$

$$c_1 + c_2 = 9$$

$$2c_1 = 12$$

$$\Rightarrow c_1 = 6 \mu\text{F}$$

$$C_2 = 3 \mu\text{F}$$

Q. Two capacitors  $6 \mu\text{F}$  and  $12 \mu\text{F}$  are connected in series. If the potential difference between the two ends is  $18\text{v}$ . Find the potential difference across the individual capacitor.

A  $c_1 = 6\mu\text{F}$ ,  $c_2 = 12\mu\text{F}$ ,  $v = 18$  volt.

$$\frac{1}{c} = \frac{1}{c_1} + \frac{1}{c_2}$$

$$\Rightarrow \frac{1}{c} = \frac{1}{6} + \frac{1}{12}$$

$$\Rightarrow \frac{1}{c} = \frac{2+1}{12} = \frac{3}{12} = \frac{1}{4}$$

$$\Rightarrow c \ 4\mu$$

So charge,  $Q = cv$

$$Q = 4 \times 18$$

$$Q = 72 \mu\text{C}$$

$$\text{Now, } v_1 = \frac{Q}{c_1} = \frac{72}{6} = 12 \text{ volt}$$

$$v_2 = \frac{Q}{c_2} = \frac{72}{12} = 6 \text{ volt}$$

### Parallel Plate Capacitor :

It consists of two equal and oppositely charged plate held parallel to each other at a separation between them.

Consider a parallel plate capacitor consists of two equal and oppositely charged plates P and Q.

Let,  $A \rightarrow$  Area of each plate &  $d \rightarrow$  Distance between two plates

if  $\sigma$  is the surface charge density of each plate.

$$\sigma = \frac{\text{charge}}{\text{Area}} = \frac{q}{A}$$

The electric field at any point between the two plates

$$E = \frac{\sigma}{\epsilon_0}$$

$$E = \frac{q}{A \epsilon_0}$$

Now, the potential difference between the two plates

$$V = Ed$$

$$\Rightarrow V = \frac{q}{A \epsilon_0} d$$

So, the capacitance of the capacitor

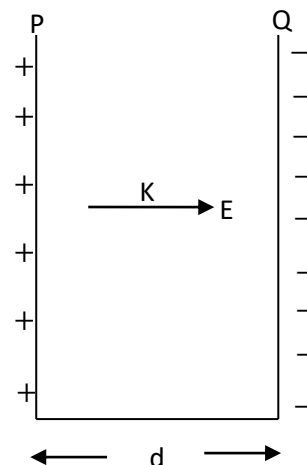

$$C = \frac{q}{V}$$

$$\Rightarrow C = \frac{q}{qd / A \epsilon_0}$$

$$\Rightarrow C = \frac{A \epsilon_0}{d} \quad \text{This is the capacitance of a parallel plate capacitor}$$

So,  $C \propto A$  and  $C \propto 1/d$

## Magnetism

### Magnetic Moment (M) :

The magnetic moment of a magnet is defined as the product of pole strength and the magnetic length.

$$M = m \times L$$

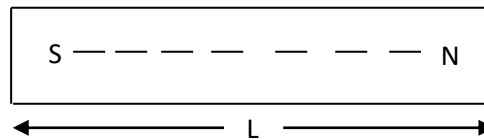

- Unit : (Amp. m) x m = Amp. M
- Its direction is from south pole to North pole of the magnet.

### Magnetic Lines of Force :

- \* These are the lines or the curves drawn around a magnet such that the tangent at any point gives the direction of the resultant magnetic field at that point.
- \* The direction of the magnetic lines of force is from magnetic N – pole towards S – pole.

But inside a magnet it is from S – pole to N – pole

### Two magnetic lines of force never intersect each other.

If they intersect at the point of intersection two tangents can be drawn to the two curves. So the direction of magnetic field at that point is along two directions, which is impossible.

### Coulomb's Law In Magnetism :

**Statement** : The magnetic force of attraction or repulsion between two poles is directly proportional to the product of their pole strength and inversely proportional to the square of the distance between them.

$$F \propto m_1 m_2$$

$$\propto 1/r^2$$

combining,  $F \propto \frac{m_1 m_2}{r^2}$

$$\Rightarrow F = K \frac{m_1 m_2}{r^2} \quad (\text{where } K \text{ is a proportionality constant})$$

- In C.G.S. system  $K = 1$ , so

$$F = \frac{m_1 m_2}{r^2}$$

- In S.I. system,  $K = \frac{\mu_0}{4\pi}$

so  $F = \frac{\mu_0}{4\pi} \frac{m_1 m_2}{r^2}$

Where,  $\mu_0$  is called magnetic permeability of free space

$$\mu_0 = 4\pi \times 10^{-7} \text{ weber / Amp m}$$

$$\Rightarrow \frac{\mu_0}{4\pi} = 10^{-7} \text{ weber / Amp.m}$$

### Unit pole :

If  $m_1 = m_2 = m$ ,  $r = 1 \text{ m}$  and  $F = 10^{-7} \text{ N}$

Since,  $F = \frac{\mu_0}{4\pi} \frac{m_1 m_2}{r^2}$

$$\Rightarrow 10^{-7} = 10^{-7} \frac{m^2}{(1)^2}$$

$$\Rightarrow m^2 = 1$$

$$\Rightarrow m = 1 \text{ unit}$$

unit pole is that which when placed near a similar pole at a distance of 1m, repel by a force of  $10^{-7} \text{ N}$ .

**Magnetic Flux :**

The magnetic flux linked with a surface in a magnetic field is defined as the product of the magnetic field and the area of the surface.

$$\phi = BA$$

- \* **Unit :** (S. I. unit)- Weber  
 (C.G.S unit) - Maxwell  
 1 Weber =  $10^8$  Maxwell

**Magnetic Flux Density / Magnetic Field / Magnetic Induction :**

The magnetic flux density is defined as the magnetic flux per unit area of the surface.

$$B = \frac{\phi}{A}$$

- \* **Unit :** (S. I.) - Tesla =  $\frac{\text{Weber}}{m^2}$   
 (C.G.S )- Gauss =  $\frac{\text{Maxwell}}{cm^2}$   
 1 Tesla =  $10^4$  Gauss



## UNIT-10 CURRENT ELECTRICITY

### Electric Current :

When there is a potential difference between the two ends of a conductor, the charge will flow from one end to other.

The electric current flowing through the conductor is defined as the amount of charge flowing per sec across any section of the conductor.

i.e  $I = \frac{q}{t}$

→ If 'n' no of electrons flowin

then,  $q = ne$       so,  $I = \frac{q}{t} = \frac{ne}{t}$

→ Unit : Ampere

### Ohm's Law :

At constant temperature, the current flowing through a conductor is directly proportional to the potential difference between the two ends of the conductor.

$$V \propto I$$

$$\Rightarrow V = RI$$

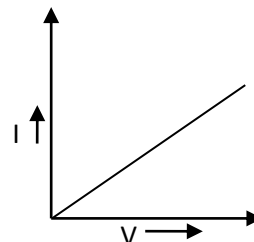

$$\Rightarrow I = \frac{V}{R} \quad [R = \text{Resistance of the conductor}]$$

**Limitations :** Ohm's law is valid at constant temperature.

### Grouping of Resistance:

#### **(a) Resistance in series:**

The resistances are said to be connected in series if the current flowing through each resistance is same.

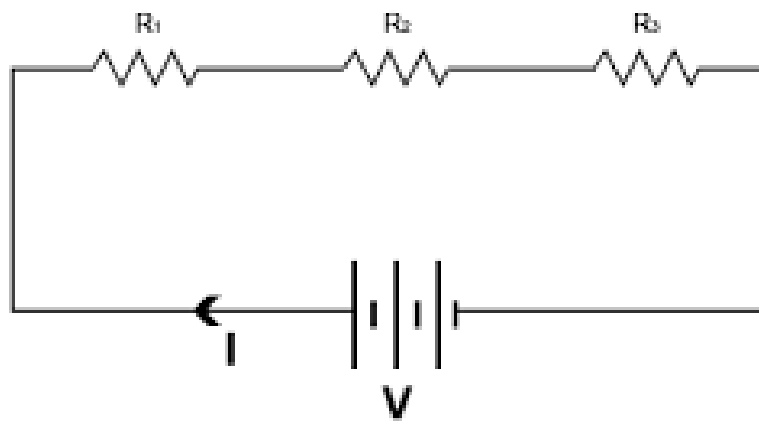

Consider a group of resistances  $R_1$ ,  $R_2$ ,  $R_3$  are connected in series.

Let  $I$  be the current flowing through each resistance

So, the potential difference

$$V_1 = IR, \quad V_2 = IR_2, \quad V_3 = IR_3$$

If  $R_s$  is the equivalent resistance of this series grouping.

The Net potential difference,  $V = IR_s$

We have

$$V = V_1 + V_2 + V_3$$

$$\Rightarrow IR_s = IR_1 + IR_2 + IR_3$$

$$\Rightarrow IR_s = I(R_1 + R_2 + R_3)$$

$$\Rightarrow \boxed{R_s = R_1 + R_2 + R_3}$$

**(b) Resistance in parallel:**

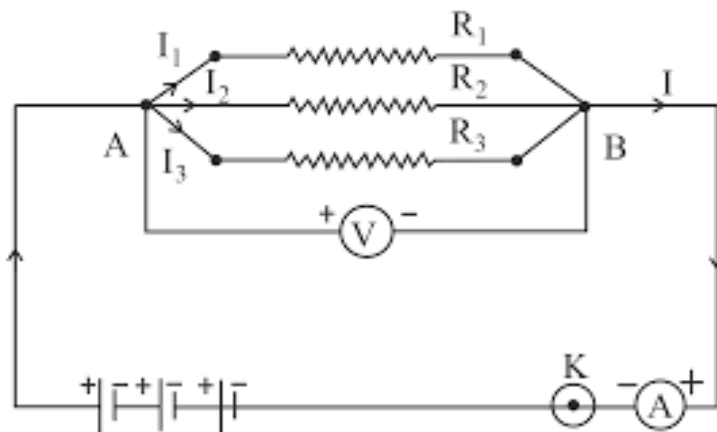

The resistances are said to be connected in parallel if the potential difference across each resistance is same.

Consider a group of resistances.

$R_1$ ,  $R_2$ ,  $R_3$  are connected in parallel.

Let  $V$  be the potential difference across each resistance.

If  $I_1$ ,  $I_2$ ,  $I_3$  are the current through the resistances.

$$I_1 = \frac{V}{R_1}$$

$$I_2 = \frac{V}{R_2}$$

$$I_3 = \frac{V}{R_3}$$

If  $R_p$  is the equivalent resistance of this parallel grouping the total current.

$$I = \frac{V}{R_p}$$

We have,  $I = I_1 + I_2 + I_3$

$$\Rightarrow \frac{V}{R_p} = \frac{V}{R_1} + \frac{V}{R_2} + \frac{V}{R_3}$$

$$\Rightarrow \frac{V}{R_p} = V \left( \frac{1}{R_1} + \frac{1}{R_2} + \frac{1}{R_3} \right)$$

$$\Rightarrow \frac{1}{R_p} = \frac{1}{R_1} + \frac{1}{R_2} + \frac{1}{R_3}$$

### **Kirchoff's laws :**

#### **(a) 1<sup>st</sup> Law (Kirchoff's Current law of Junction Law) :**

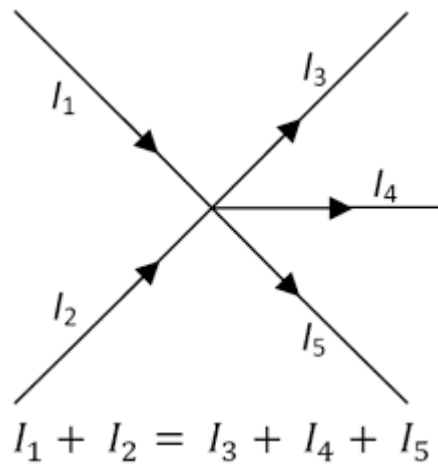

The algebraic sum of all the currents meeting at any junction point is zero.

i.e  $\sum I = 0$

$$I_1 + I_2 - I_3 - I_4 - I_5 = 0$$

$$\Rightarrow I_1 + I_2 = I_3 + I_4 + I_5$$

i.e at any P junction point the current entering is equal to the current leaving.

\* Kirchoff's current law is based upon conservation of charge.

### **(b) 2<sup>nd</sup> Law (Kirchoff's Voltage law or loop Rule) :**

In any closed circuit the total potential is equal to zero.

$$\sum V = 0$$

$$\Rightarrow \sum IR + \sum E = 0$$

Kirchoff's voltage law is based upon the conservation of energy.

### **Wheatstone Bridge:**

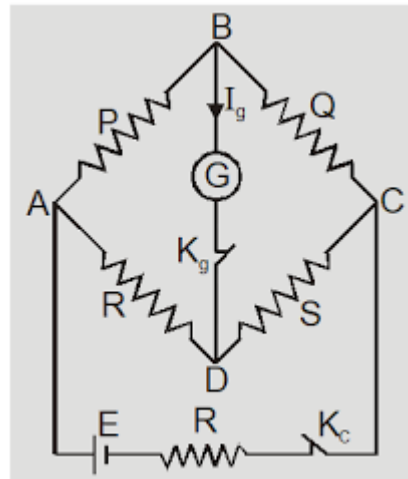

It is an electric arrangement of four resistances connected in the form of a bridge.

Consider four resistances P, Q, R and S connected in the form of a bridge.

Between A and C a battery is connected by means of a key. A Galvanometer of resistance G is connected between B and D.

When the key is closed, the distribution of current is as shown in the figure.

Applying Kirchhoff's voltage law

for the loop ABDA

$$I_1 P + I_g G - (I - I_1) R = 0 \quad (i)$$

For the loop BCDB

$$(I_1 - I_g) Q - (I - I_1 + I_g) S - I_g G = 0 \quad (ii)$$

When the bridge is balanced there is no current through the galvanometer. i.e.  $I_g = 0$

So equation (i) becomes

$$I_1 P - (I - I_1) R = 0$$

$$\Rightarrow I_1 P = (I - I_1) R \quad \dots\dots\dots(iii)$$

Equation (2) becomes

$$I_1 Q - (I - I_1) S = 0$$

$$\Rightarrow I_1 Q - (I - I_1) S \quad \dots\dots\dots(iv)$$

Dividing equation (3) & (4)

$$\frac{I_1 P}{I_1 Q} = \frac{(I - I_1)R}{(I - I_1)S}$$

$$\Rightarrow \boxed{\frac{P}{Q} = \frac{R}{S}}$$

This is the balanced condition of the Wheatstone bridge.

### **Biot – Savart’s Law :**

This law gives the magnetic field / magnetic induction / magnetic flux density at any point due to a current carrying conductor.

The magnetic induction at point P due to the small element of length dL.

$$dB \propto I$$

$$\propto dL$$

$$\propto \sin\theta$$

$$\propto 1/r^2$$

$$\text{Combining, } dB \propto \frac{Idl \sin \theta}{r^2}$$

$$\text{Or, } dB = K \frac{Idl \sin \theta}{r^2}$$

$$\text{In C.G.S System } K = 1, \quad dB = \frac{Idl \sin \theta}{r^2}$$

$$\text{In S.I. System } K = \frac{\mu_0}{4\pi}, \quad dB = \frac{\mu_0}{4\pi} \frac{Idl \sin \theta}{r^2}$$

Where  $\mu_0 \rightarrow$  Magnetic permeability of free space

$$\mu_0 = 4\pi \times 10^{-7} \text{ weber / Amp. m.}$$

In vector form:

$$d\vec{B} = K \frac{Idl \sin \theta}{r^2} \hat{r} \quad (\text{where } \hat{r} = \frac{\vec{r}}{r}, \text{ a unit vector})$$

$$d\vec{B} = K \frac{Idl \sin \theta}{r^3} \vec{r} = K \frac{I(d\vec{l} \times \vec{r})}{r^3}$$

In C.G.S. system  $K = 1$  So,  $d\vec{B} = \frac{I(d\vec{l} \times \vec{r})}{r^3}$

In S.I system  $K = \frac{\mu_0}{4\pi}$  So,  $d\vec{B} = \frac{\mu_0}{4\pi} \frac{I(d\vec{l} \times \vec{r})}{r^3}$

### Force on a moving charge in a uniform magnetic field

When a particle of charge  $q$  moving with a velocity  $v$  in a uniform magnetic field  $B$  making an angle with the field, the force on the charge particle

$$F = qvB \sin\theta$$

In vector form,  $\vec{F} = q(\vec{v} \times \vec{B})$

\* If  $\theta = 0^\circ$ ,  $\sin \theta = 0$ , So,  $F = 0$

i.e. No force when the charge moves parallel to the magnetic field.

\* If  $\theta = 90^\circ$ ,  $\sin \theta = 1$ , So,  $F = qvB$  ( Maximum )

i.e the force will be maximum when the charge moves perpendicular to the magnetic field.

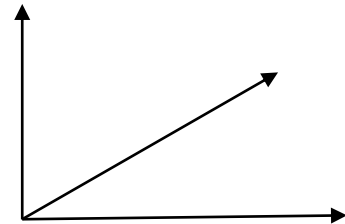



## Force acting on a conductor placed in a uniform magnetic field

Consider a conductor XY carrying current I placed in uniform magnetic field  $\vec{B}$ .  
Let dq be the small amount of charge moving from X to Y with a velocity  $\vec{v}$ .

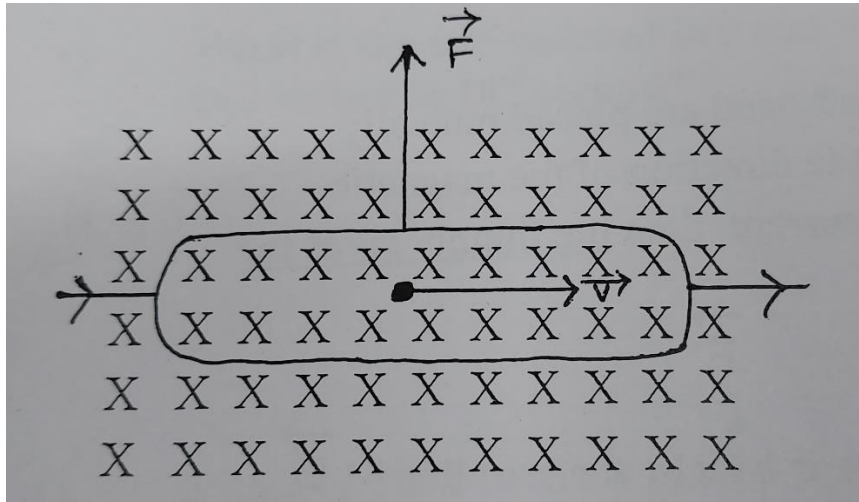

The force  $d\vec{F}$  by this charge is given by,

$$d\vec{F} = dq(\vec{v} \times \vec{B})$$

If the charge travels a small distance  $d\vec{l}$  in a small time  $dt$ , then  $\vec{v} = \frac{d\vec{l}}{dt}$

$$\text{So, } d\vec{F} = dq \left( \frac{d\vec{l}}{dt} \times \vec{B} \right)$$

$$d\vec{F} = \frac{dq}{dt} (d\vec{l} \times \vec{B})$$

$$\Rightarrow d\vec{F} = I (d\vec{l} \times \vec{B})$$

So, the net force acting on the conductor,

$$\boxed{\vec{F} = I (\vec{l} \times \vec{B})}$$

$$|\vec{F}| = ILB \sin\theta$$

\*

If  $\theta = 0^\circ$ ,  $\sin \theta = 0$ , So,  $F = 0$

i.e. No force when the conductor is placed parallel to the magnetic field.

\*

If  $\theta = 90^\circ$ ,  $\sin \theta = 1$ , So,  $F = ILB$  ( Maximum )

i.e the force will be maximum when the conductor is placed perpendicular to the magnetic field.

**Q. A proton is moving with a velocity of  $2 \times 10^7$  m/sec in a uniform magnetic field of  $340 \text{ Wb/m}^2$  in a direction perpendicular to the field. Find the force.**

**Q. A charge of 2 coulomb moving with a velocity of  $(2\mathbf{i} + 3\mathbf{j})$  m/sec in a uniform magnetic field  $(\mathbf{i} - 2\mathbf{j} + \mathbf{k})$  Tesla. Find the magnitude of the force on the charge.**

## **Unit-11**

### **Electromagnetic Induction**

#### **Faraday's laws of electromagnetic induction:**

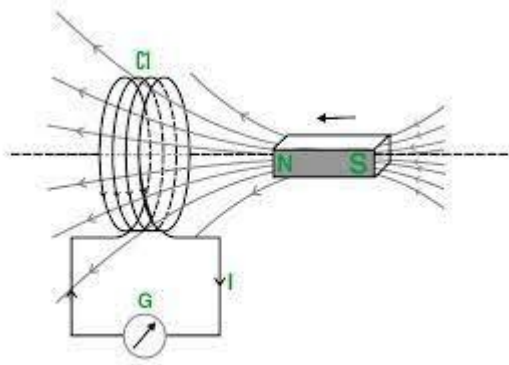

a) Whenever there is a change in magnetic flux linked with a circuit or a coil, an e.m.f. is induced.

b) The induced emf exists so long as the change in magnetic flux continues.

c) The induced emf is directly proportional to the rate of change of magnetic flux.

$$e \propto \frac{d\phi}{dt} \quad \Rightarrow \quad e = K \frac{d\phi}{dt} \quad [ K = \text{proportionality constant} ]$$

Here  $K = -1$  so,  $e = -\frac{d\phi}{dt}$  ( -ve sign is due to the direction of induced emf.)

$$|e| = \frac{d\phi}{dt} \quad \text{If the coil is of } N \text{ number of turns, then} \quad |e| = N \frac{d\phi}{dt}$$

- When the coil is placed perpendicular to the magnetic field

$$|e| = \frac{NBA}{t}$$

### Lenz's law:

The direction of induced emf is such that it opposes the cause which produces it.

- Q. What is the emf induced in a coil when the magnetic flux changes from 1.5 weber to 2 weber in  $10^{-2}$  second?
- Q. A coil of 1000 turns is placed perpendicular to a magnetic field of 0.0125 Tesla. If the area of the coil is  $5 \times 10^{-3} \text{ m}^2$ , find the emf induced in 10 milliseconds.

### Fleming's Right hand Rule:

When first finger, central finger and the thumb of right hand are placed mutually perpendicular directions, if the first finger gives the direction of the magnetic field, thumb gives the direction of motion of conductor then the central finger gives the direction of the induced current

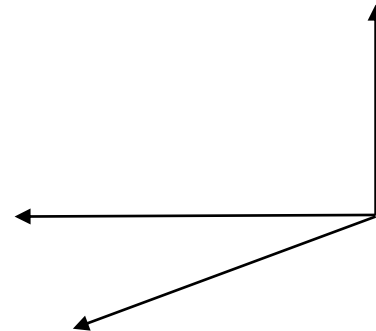
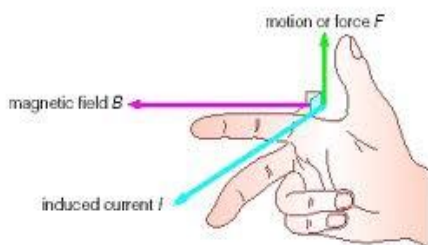

### Fleming's Left hand rule:

When first finger, central finger and the thumb of left hand are placed mutually perpendicular directions, if the first finger gives the direction of the magnetic field, central finger gives the direction of the electric current then the thumb gives the direction of force.

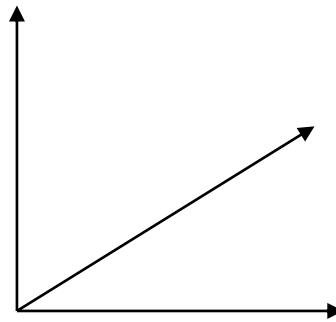
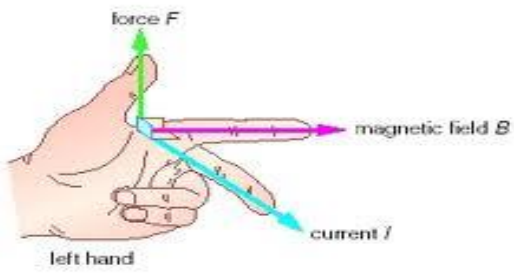

**UNIT-12**  
**MODERN PHYSICS**

**LASER :**

LASER stands for Light Amplification by Stimulated Emission of Radiation

**Principle of laser :****Stimulated absorption:**

We know that electrons exist at specific “energy levels” or “states” which is the characteristic of a particular atom or molecule. These energy levels can be imagined as orbits around the nucleus of an atom

Usually, the atom exists in the lower energy state  $E_1$  (i.e ground state) and  $E_2$  be the higher allowed energy state. If a photon of light having energy  $E_2 - E_1$  is incident on this atom, the atom will absorb photon and jump to higher energy state  $E_2$ . This process is called as stimulated absorption. The incident photon has stimulated the atom to absorb energy

**Spontaneous emission:**

Suppose the atom is in the higher excited state  $E_2$ , if we just leave the atom there it will eventually come down to the lower energy state by emitting a photon having energy ( $E_2 - E_1$ ). This process is called spontaneous emission

**Stimulated emission:**

Atom stays about 10 nanoseconds in an excited state which is called as average life time of the atom to stay in that excited state. Hence, the atoms in an excited state is more likely to emit spontaneously. There are atoms which have certain excited state having life time of the order of millisecond such states are called as meta stable states. If the atom is in such a meta stable state with energy  $E_2$  and photon of energy,  $E_2 - E_1$  is incident on it, the incident photon interacts with the atoms in the higher energy state (meta stable state) and brings the atoms to come down to the lower energy state.

A fresh photon is emitted in this process. In this case, the incident photon has stimulated the atom in the excited state to come down to the lower energy state. The process in which the atom emits a photon due to its interaction with a photon incident on it is called as stimulated emission.

**Population inversion:**

$E_2$  = Energy of the meta stable state

$E_1$  = Energy of the lower energy state

Suppose a photon of energy ( $E_2 - E_1$ ) is incident on one of the atom in the meta stable state, this atom comes down to the lower energy state „ $E_1$ “ by emitting a photon in the same phase(i.e., Coherent), Energy (i.e., same frequency or wave length) and direction as in the case of incident photon.

These two photons interact with two more atoms in the meta stable state  $E_2$  and so on, as a result the number of photons keeps on increasing. All the photons have same phase, same energy and same direction, thus amplification of light will be achieved.

However, higher energy meta stable state „ $E_2$ “ must have larger numbers of atoms than the number in the lower energy state „ $E_1$ “ for all the time to achieve the amplification and to obtain a stable lasing action. When the higher energy state has more number atoms than the lower energy state, this condition is called as population inversion.

### **Optical pumping:**

To sustain the laser action, the number atoms in the higher energy state „ $E_2$ “ must be more than the atoms in the lower energy state „ $E_1$ “. The meta stable state  $E_2$  should continue to get atoms and the atoms should be continuously removed from the lower state „ $E_1$ “ with the help of photons emitted by an external optical source. This process is called as optical pumping. If the luminous energy (light) is supplied to a system for causing population inversion, then the pumping is known as optical pumping.

### **Properties of LASER**

#### **→ Monochromatic**

Light emitted from a laser is vastly more monochromatic than that emitted from a conventional mono-chromatic sources of light.

#### **→ Coherent**

The laser light is highly coherent in space and time. This property enables us to realize a tremendous spatial concentration of light power.

#### **→ Directionality**

Light emitted from conventional sources spread in all directions. Laser beam is highly parallel and directional. A narrow beam of light can be obtained from it.

### → High intensity

As the laser beam has the ability of focusing over an area as small as  $10^{-6}$  cm<sup>2</sup>, therefore, it is highly intense beam. Also, the constructive interference between the coherent photons lead to a high amplitude and hence a high intensity.

### Uses :

#### 1) In surgery :

Laser light can be used for retina surgery in the eye for tumor operation etc.

#### 2) In Industry :

Laser light can be used for drilling, cutting in various industries.

#### 3) In communication :

By using laser source the signal can be sent over long distance through optical fibre.

#### 4) In war fare :

During war it can be used as a powerful weapon.

#### 5) For weather forecasting :

It can be used as a signal for weather forecasting.

### Photoelectric effect.

The process of emission of electrons from a metal surface when light of shorter wavelength is incident upon the metal surface.

### Laws of photoelectric effect :

- 1) The photoelectric emission is a sudden process.
- 2) The photoelectric current is directly proportional to the intensity of light and independent of frequency of light.
- 3) The maximum velocity of emitted electrons is independent of intensity of light and depends upon frequency of light.
- 4) The emission of electrons stops below a certain minimum frequency known as **threshold frequency**.

### Einstein's photoelectric equation :

According to Einstein's theory the energy of incident light ,  $E = hf$

(  $h$  = Planck's constant ,  $f$  = frequency of light )

When light is incident upon the surface of metal, the electrons possess certain minimum energy known as work function ( i.e. the minimum energy required to pull an electron out from the surface of metal ) and comes out with the remaining energy as



kinetic energy.

$$hf = \frac{1}{2} m v_{\max}^2 + \phi \quad (\phi \text{ is the work function})$$

$$\frac{1}{2} m v_{\max}^2 = hf - \phi$$

$$\frac{1}{2} m v_{\max}^2 = hf - h f_0 \quad (f_0 \text{ is threshold frequency})$$

$$\frac{1}{2} m v_{\max}^2 = h(f - f_0) \quad (\text{This is Einstein's Photoelectric equation})$$

## Wireless transmission

### Ground Waves:

Due to curvature of earth the radio waves from the transmitting station is unable to reach at the distance places from earth. The stations which are nearer to the transmitting stations can receive the signal directly. These waves are called the ground waves.

### Sky Waves :

Due to curvature of earth the radio waves from the transmitting stations cannot reach the distant places of earth. But these waves can be received after reflections from the ionosphere. These waves which are received after reflection from the ionosphere are known as sky waves.

### Space Waves :

If the frequency of the radio wave is very large ( $> 30$  MHZ), ionosphere does not reflect such waves. Thus an antenna is placed on the surface of earth. Such waves propagated through the antenna are known as space waves.

In order to reach the waves at the distant places. The height of the antenna should be very large.